

Combi

Combi 嬰兒餐搖椅
Combi Hi-Low Rocking Chair

Roanju

RU-490

使用說明書
Instruction Manual

本產品為一般家庭用製品。因商業用途而引致的損壞恕不受理。
This is a general family-use product. Any damage caused by commercial use will not be repaired.

請在使用前詳細閱讀本說明書，在理解後按照記載內容正確安裝及使用。

Please read this user guide carefully and assemble the product correctly before use.

- 閱讀後請保存本說明書，以供日後參考。
Please keep this user guide for future reference.
- 需要安裝的部件，請詳閱本說明書然後正確安裝。
Follow the instructions in this user guide when assembling the required parts.
- 如果需要轉讓本產品時，請將本說明書一併交付對方。
Also attach this user guide in case the product is to be transferred to others to use.



使用前 Before use

- 本製品是供幼兒在室內使用的多用途餐椅，可以作為簡易小床或搖椅等用途使用。
This is an indoor and multi-functional baby chair. It can be used as a simple infant bed or a rocking chair.
- 建議連續使用時間：當作小床時使用為 60分鐘 / 搖椅時使用為15分鐘
※一天合計使用時間 3~4小時
Recommended maximum continuous usage : 60 minutes as a bed / 15 minutes as a rocking chair.
※3~4 hours totally in a day.
- 適用本製品之幼兒年齡：0~4歲左右（連衣服計算體重在18kg以下）。
Applicable age for using this product : 0~4 years old (Weighing 18kg or below including clothes)

開封後請確認下列部件是否齊全。

Please check if any parts are missing after opening the sales package.

包裝箱應包含下列摺包部件，開封後請確認部件是否齊全。

Sales package should include the followings. Please check if any parts are missing after opening the sales package.

- Roanju 主體（附椅墊）
Roanju main body (with seat cushion)
- 小桌
Table
- 嬰兒用品箱
Storage box
- 使用說明書
Instruction manual



Roanju主體
Roanju main body



小桌
Table



嬰兒用品箱
Storage box



使用說明書(本書)
Instruction manual (this book)

使用方法一覽表 Guidelines to use

本產品可作為簡易小床或餐椅使用。根據幼兒的月齡，請遵守以下使用條件。

This product can be used as a simple infant bed or a baby chair. Please follow the below conditions according to baby's age.

月齡參考 Age reference		初生 ~ 2、3個月 New born ~ 2, 3 months	2、3個月 ~ 5、6個月 2, 3 months ~ 5, 6 months	5、6個月 ~ 48個月 5, 6 months ~ 48 months
發育狀態參考 Body development		頸部已發育 Neck muscle developed	直至腰部完全發育 Until waist muscle developed	腰部已發育 Waist muscle developed
使用方法 Using method	簡易小床 Simple infant bed	○	○	×
	餐椅 Baby chair	×	○	○
搖椅 Rocking chair		○	簡易小床 Simple infant bed	○
			餐椅 Baby chair	
		靠背在 ①、② 角度時可作搖椅使用，③ 則不適用於搖椅。 Only ① and ② backrest positions applicable for rocking chair. Position ③ not to be used.		×
安全帶 Seat belt	肩帶 Shoulder belt	必須使用 Compulsory usage	必須使用 Compulsory usage	沒有限制 No limitation
	腰/中腰帶 Waist/crotch belt	必須使用 Compulsory usage	必須使用 Compulsory usage	必須使用 Compulsory usage
靠背角度使用範圍 Backrest angles		①	① ② ③	③ ④ ⑤

● 初生嬰兒

New born

在本說明書之內，初生嬰兒意指體重在2.5kg以上，懷孕期在37週以上的幼兒。

New born stated in this instruction manual refers to baby who weighs 2.5kg or above and had been carried for more than 37 weeks in pregnancy period.

安全使用守則 For safe and proper use

- 本章記載了使用上需要了解的警告及注意事項，是為確保閣下能正確使用本產品，目的是防止潛在的危險或損害的發生。
不按照本說明書指引使用本產品，可能對幼兒或監護人造成傷害。

The warning and caution events mentioned in this user guide are aimed at proper use of this product and prevention of potential danger to baby or damage to product.

Failure to comply may result in injury to baby or protector.

- 本說明書所提示的 [警告]、[注意] 等標識內容說明了假如不正確遵守該等注意事項時所有可能引致的危險或損害，並根據其迫切程度區分，是非常重要的內容，請必須遵守。

[Warning] and [Caution] indicate the potential consequences if the mentioned are not followed properly and they are categorized according to the level of severity.

標識內容 Meaning of mark	
	警告 WARNING 表示錯誤操作可引致死亡或嚴重傷害。 Improper usage may result in death or severe injury.
	注意 CAUTION 表示錯誤操作可引致使用者傷害或產品受損。 Improper usage may result in injury or damage to product.

- 必須遵守以下列區分類別的內容。
Please follow the contents that require your attention are marked with the following symbols.

	警告或注意事項的內容。 Content of warning or caution.
	禁止行為的內容。 Content of prohibition.
	補充說明。 Additional information.

警告 WARNING

不正確操作會可能導致危險發生。
Improper usage may cause danger.

防止幼兒因突如其來的跌倒或溜出而構成重大傷害或死亡。
PREVENT SERIOUS INJURY OR DEATH FROM FALL OR SLIDING OUT.

防止意外發生 To prevent accidents happening

- 切勿讓幼兒單獨坐在餐椅上。
NEVER LEAVE CHILD UNATTENDED.
- 幼兒突如其來的動作，即使已扣上安全帶也有可能令其跌出餐椅。請小心看顧幼兒。
Even buckled with seat belt, child's unexpected acts may cause it fall off the chair. Pay attention when using the chair.



- 請務必扣上安全帶。
ALWAYS SECURE CHILD IN THE RESTRAINT.
- 必須放在監護人看到的地方使用餐椅。
ALWAYS KEEP CHILD IN VIEW WHILE IN HIGH CHAIR.

- 作為小床使用時，切勿讓幼兒俯臥，以免引致意外窒息。
For using a infant bed, avoid the baby from lying prone in case it may accidentally suffocate.



- 不要讓幼兒爬進餐椅下及不可讓幼兒操作餐椅。
Keep away child from crawling underneath the chair, and do not allow child to operate the chair.

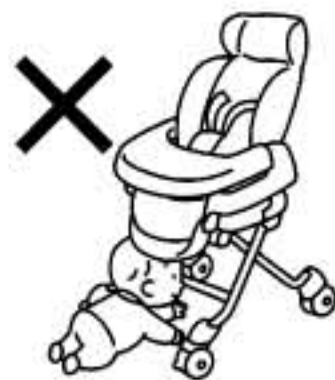

- 請勿讓成人坐在餐椅上，或在餐椅上放置重物。
Never let an adult sit on the chair or add load onto the chair.



- 請勿於摺合狀態使用餐椅。
Never use the chair in a folded position.



安全使用本產品 For safe use of this product

警告 WARNING 不正確操作會有可能導致危險發生。Improper usage may cause danger.

防止意外發生 To prevent accidents happening

- 不要使用曾受強烈撞擊或從高處墮下而引致變形、破損的餐椅。
Never use a chair has been exposed to strong impact or fallen from high with deformation or cracks, or damaged parts.



- 不要於下列地方使用餐椅。
• 暖爐等靠近火的地方
• 可能有重物掉落的地方
Never use the chair in the following places.
• By the heater or fire.
• By places where there may be a potential danger of things falling onto the chair.



- 請勿隨意改造、分解或修理餐椅。
Do not remodel, disassemble or repair the chair by yourself.



- 請勿使用未經稀釋的中性清潔劑原液、天拿水、汽油或其他有機溶劑進行清潔，或在主體上噴灑殺蟲劑。
Never use undiluted neutral detergent, thinner, gasoline or other organic agents to clean the main body frame. Do not spray insecticide onto the main body.



按照美國ASTM標準

According to ASTM Standard

警告 WARNING

在任何時間幼兒使用餐椅時應確保扣好安全帶，本小桌設計不是用作固定幼兒在餐椅上。建議能挺直坐的幼兒用此餐椅。
THE CHILD SHOULD BE SECURED IN THE HIGH CHAIR AT ALL TIMES BY THE RESTRAINING SYSTEM. THE TRAY IS NOT DESIGNED TO HOLD THE CHILD IN THE CHAIR. IT IS RECOMMENDED THAT THE HIGH CHAIR BE USED ONLY BY CHILDREN CAPABLE OF SITTING UPRIGHT UNASSISTED.

防止幼兒掉落 To prevent child from falling off

- 必須使用腰帶。使用搖擺功能時必須使用肩帶。(請參照P.14) 如不正確使用安全帶可能令幼兒掉落，或意外被安全帶纏住頸部。
Always use waist belt and crotch belt. Apply the shoulder belt as well when using the rocking function. (Refer to P.14) Failure to do so may result in the belt getting caught around child's neck when slipping.



- 請配合幼兒體形調節安全帶至適當長度使用及扣上安全帶。(請參照P.11) 每次改變斜躺角度時，請重新調節安全帶。
Securely fasten the seat belt and adjust the belt as according to the size of the child (Refer to P.11) Re-adjust it again every time after changing the recline angle.



- 注意不可讓幼兒站立於在餐椅、小桌或扶手上。
Do not allow child standing on the chair, child hanging over from the table or the armrest.



- 請在監護人陪同下才讓幼兒上落餐椅。
Always with parental guardian to do seating and unseating the child in the chair.



- 當幼兒正在使用時，請勿提起或移動餐椅。
Do not lift or move the chair when a child in it.



- 當幼兒正在使用時，請勿調節高度或操作收合杆。
Do not operate the height adjustment lever or the folding lever when a child in the chair.



警告 WARNING 不正確操作會有可能導致危險發生。Improper usage may cause danger.

防止餐椅翻倒而令幼兒掉落

To prevent chair from tipping over which in turn may cause child to fall off

- 除移動餐椅之外，請鎖上方向輪使用。(請參照P.8)
Always lock the swivel wheels to use except when moving the chair (refer to P.8).



- 不要一次讓兩個或以上的幼兒乘坐。
Never carry more than one child at once.



- 請不要使用餐椅於傾斜處、台階、有高低差異的場所，也不要使用於花磚地面或其他易滑倒的場所。
Never use the chair on slope, staircase, leveling, tile or other slippery floors.



- 如有發現破損或異常情況，請立即停止使用。請立即停止使用。
Stop using the product if any damage or malfunctioning is found. Contact agent or shops.



- 不要讓幼兒操作餐椅（如方向輪鎖等），以免令幼兒掉落餐椅。
Do not allow child operate the chair (e.g. swivel lock) in case it may cause child to fall off the chair.



注意 CAUTION 如果使用方法錯誤，可能引致受傷或造成產品故障。Improper usage may result in injury or damage to product.

- 每當改變斜躺角度後，必須鎖上靠背鎖。
Always lock the backrest lock after adjusting the recline angle.
- 必須安裝椅墊後使用餐椅。座椅上有孔穴或突出部分，可能引致幼兒手指受傷的危險。
Make sure to attach the seat cushion before use. Holes or protrusions on an un-cushioned chair may injury to the child.
- 請勿將餐椅作乘載以外或其他的用途（如搬運物品、腳踏等）。
Do not use the chair for any purposes (e.g. as a trolley or a step) other than seating a child.

部件名稱
Name of parts

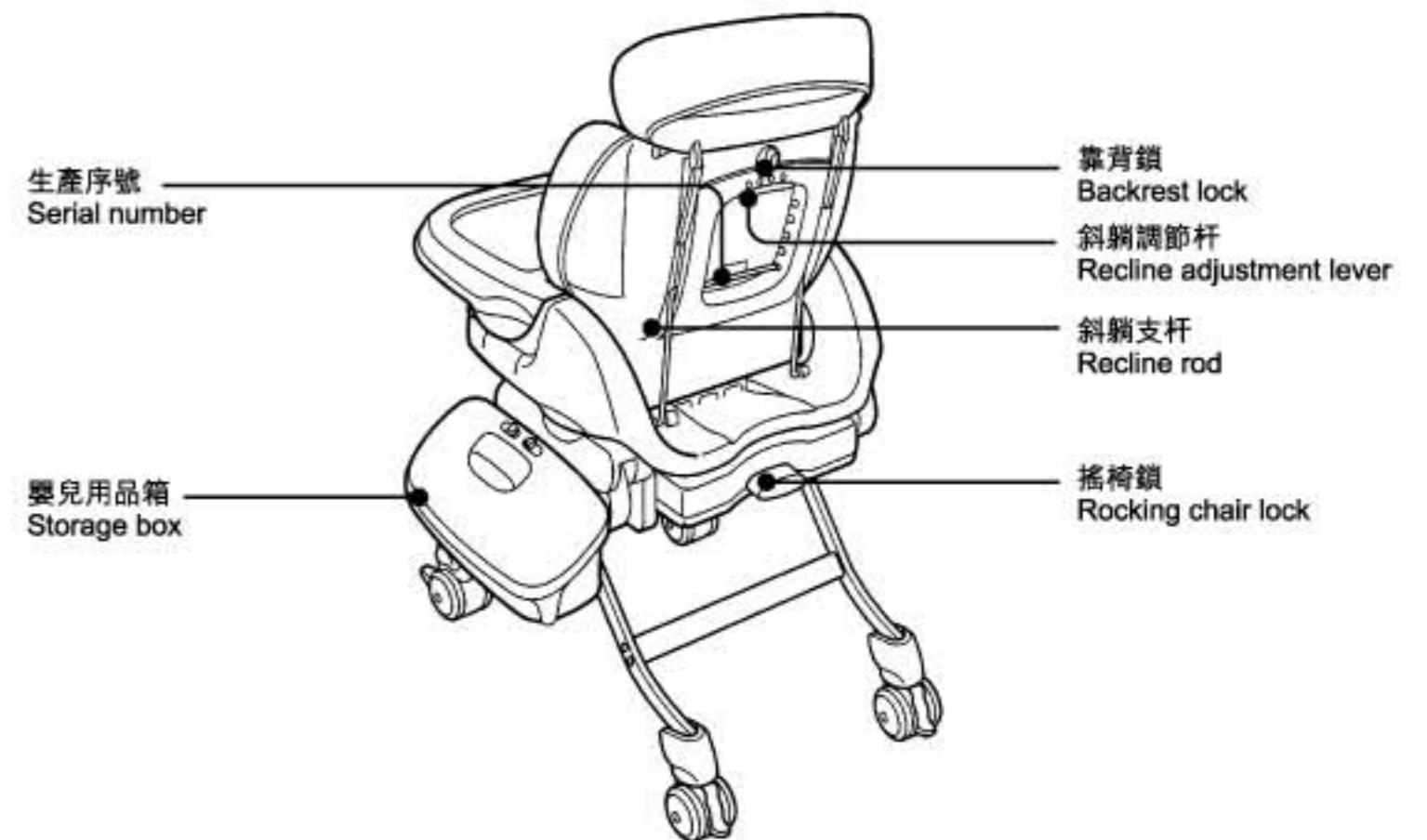
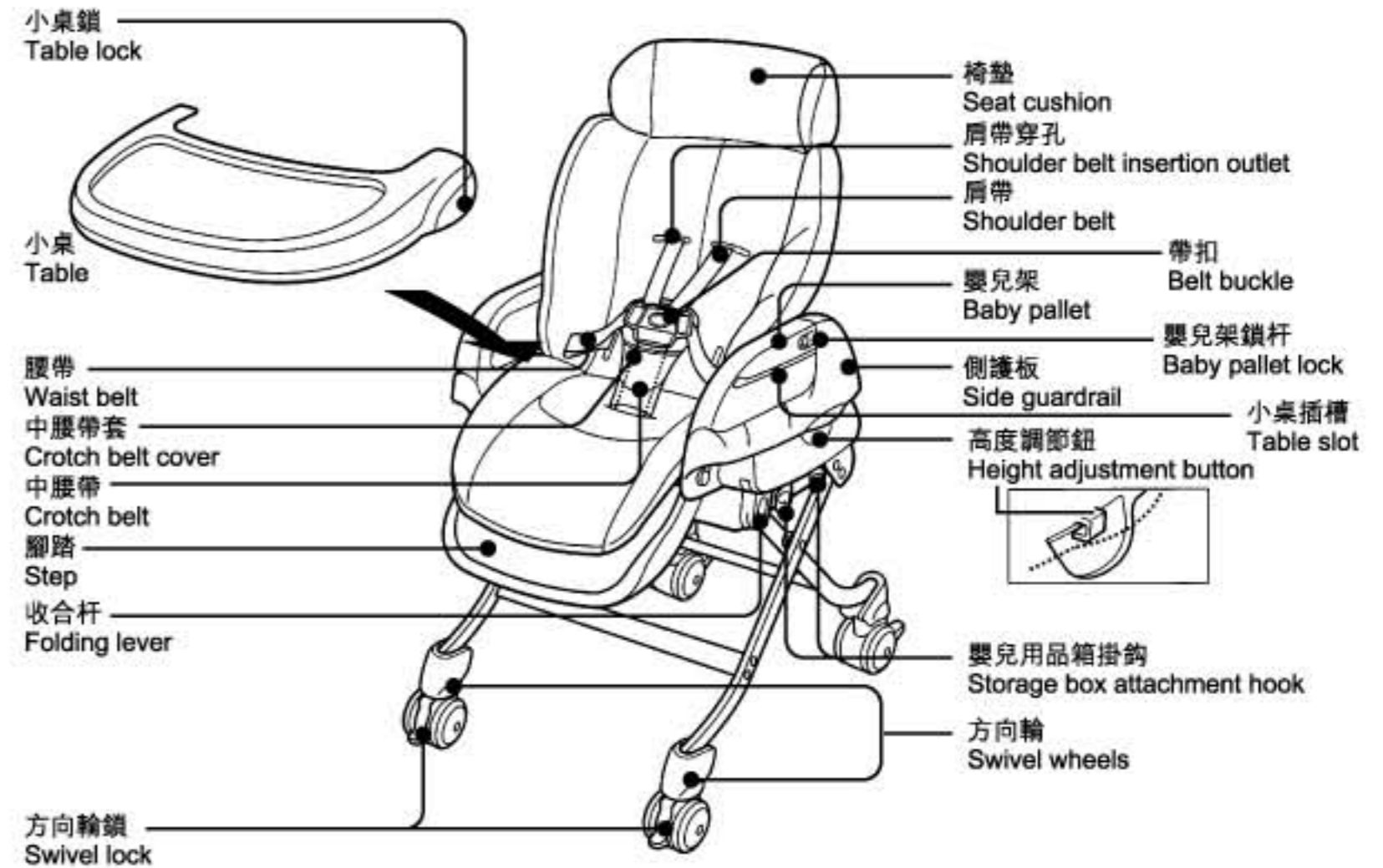

調節餐椅高度 Adjusting height of chair

高度可配合房間或用途而作5段高度調節。

Chair can be adjusted to 5 different heights according to different environments or usages.

警告 WARNING

當幼兒正在使用時，請勿調節餐椅高度，以免令幼兒意外掉落。

Do not adjust the height of chair when it is in use. Otherwise the child may fall off accidentally.

注意 CAUTION

- 確認左右的高度調節標示是否一致。如果不一致時，要再度進行調節，否則可能會引致意外發生或造成傷害。
Make sure the left and right height indications are the same. Re-adjust the height if both are not match. Otherwise it may cause of accident or damage.
- 當降低高度時，腳輪等會前後移動，要留意足部的安全。
Beware your feet. The wheels may move forward or backward when lowering the height of the chair.
- 調節高度前，必須先將搖擺鎖鎖定，否則可能對嬰孩引致傷害或造成產品故障。
Always lock the swing before adjusting the height. Otherwise it may cause of damage.
- 調節高度時，注意不要將手部放到餐椅腳部中間，以免意外夾傷。
Hands should be clear from the space between the chair legs when adjusting the chair height. Otherwise hands may get pinched accidentally.

- 1** 將方向輪的左右兩方鎖定。
Lock the swivel wheels.

請參照P.8「使用方向輪」。
Refer to P.8 Using the swivel wheels.

- 2** 把左右兩端的高度調節鈕由下往上按，同時將主體提起或放低。
Press on both left and right height adjustment button and then lift or lower the main body.

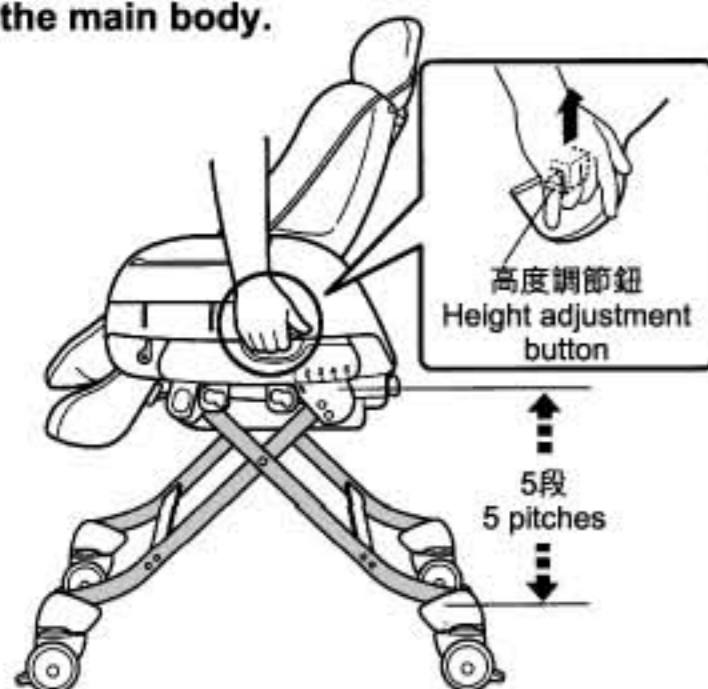

- 3** 到了所需高度時，放開左右的高度調節鈕。
Release the height adjustment buttons when reaching required height.

- 4** 確認左右的高度調節標示是相同後才開始使用。
Check the left and right height indications are the same before use.



如左右高度不一致，請重新操作。
Re-adjust if the left and right height indications are not match.

使用方向輪 Using the swivel wheels

方向輪可於室內移動餐椅時使用。
除移動餐椅時以外，請鎖上方向輪。
如右圖般鎖上方向輪鎖。

Swivel wheels can be used when moving the chair around. Lock the swivel wheels all the times except when moving the chair. Lock the swivel wheels as illustrated.

方向輪鎖定位置
Lock position of swivel wheels



警告 WARNING

除移動餐椅時以外，請鎖上方向輪，以免餐椅意外翻倒而使幼兒跌落。

Always lock the swivel wheels except when moving the chair. Otherwise the chair may tip over and cause the child to fall off accidentally.

注意 CAUTION

- 移動餐椅時，請勿橫向拖動餐椅，以免對地板造成損壞。
Do not drag the chair to the sideway when moving the chair. Otherwise damage may be caused to the floor.
- 未上鎖的方向輪會影響搖椅功能，令搖擺不順暢。
Unlocked swivel wheels may affect smoothing the operation of rocking function.
- 作為搖椅使用時請鎖上方向輪。
Always lock the swivel wheels when using as a rocking chair.

解除時 To release

將方向輪鎖往上提起，解除輪鎖。
Lift up the swivel wheel lock to release it.

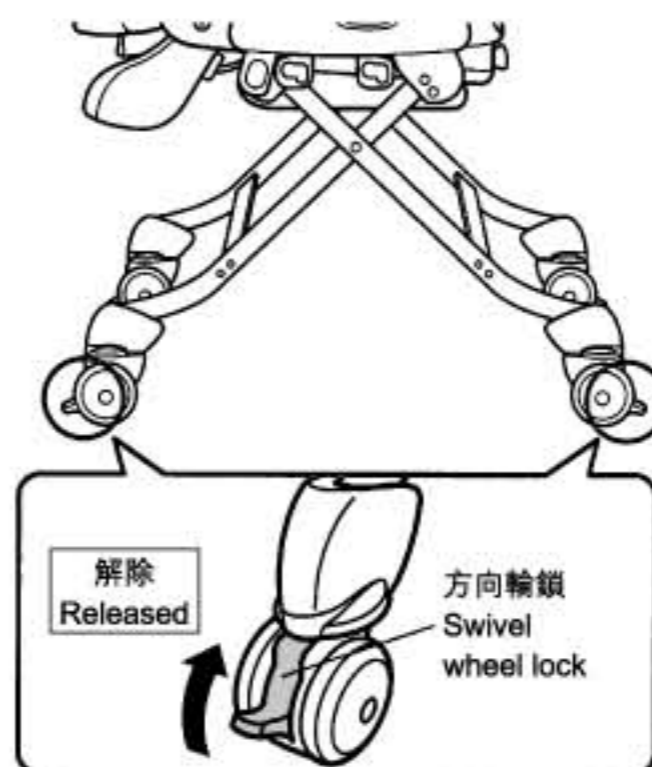

鎖定時 To lock

將方向輪鎖往下按，鎖上方向輪。
Press down to secure the swivel wheel lock.

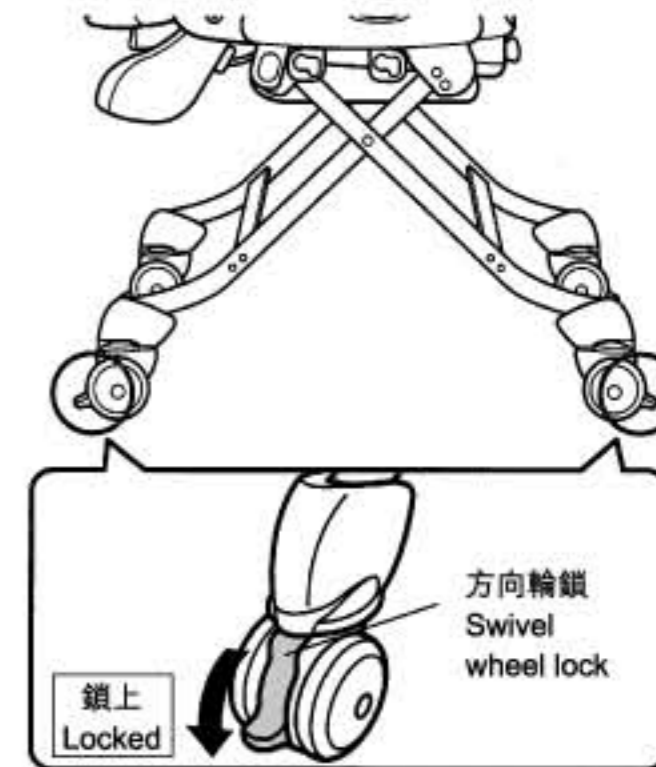

使用安全帶 (腰帶、中腰帶、肩帶) Using the seat belt (waist belt, crotch belt, shoulder belt)

在這裡把中腰帶、肩帶和腰帶統稱為安全帶。

Seat belt refers to the waist belt, the crotch belt and the shoulder belt.

警告 WARNING

- 幼兒坐上餐椅後必須替其扣上安全帶。假如未有扣上安全帶或未完全裝著安全帶，有可能引致幼兒從餐椅意外跌下的危險。即使已扣上安全帶，也要留意幼兒沒有意外鬆脫，或是突然站起。
Child must be fastened with seat belt when seated. Child may fall off the chair accidentally if not secured with seat belt, or if the seat belt is not fastened properly. Also beware of child's sudden acts even when seat belt is applied.
- 當幼兒躺下時，請配合幼兒肩膀位置使用合適的肩帶穿孔。
Select proper shoulder belt insertion outlets after seating child into the chair.
- 請勿交錯左右肩帶使用，以免對幼兒頸部造成壓迫。
Do not cross over the shoulder belts to use, which may create excessive pressure to child's neck.
- 必須使用腰帶和中腰帶。使用搖椅功能時，必須連同肩帶使用。
Always use the waist belt and crotch belt. Also apply the shoulder belt when using as a rocking chair.

按照美國ASTM標準

According to ASTM Standard

警告 WARNING

在任何時間幼兒使用餐椅時應確保扣好安全帶，本小桌設計不是用作固定幼兒在餐椅上。建議能挺直自坐的幼兒用此餐椅。THE CHILD SHOULD BE SECURED IN THE HIGH CHAIR AT ALL TIMES BY THE RESTRAINING SYSTEM. THE TRAY IS NOT DESIGNED TO HOLD THE CHILD IN THE CHAIR. IT IS RECOMMENDED THAT THE HIGH CHAIR BE USED ONLY BY CHILDREN CAPABLE OF SITTING UPRIGHT UNASSISTED.

安全帶的安裝和解除方法 Attaching and releasing the seat belt.

配戴安全帶時 To attach seat belt

1. 將左右的肩帶分別穿到插扣片上端的肩帶勾上。
Match the left and right shoulder belt to the corresponding shoulder belt hooks on the insert plastics.
2. 將左右插扣片插進安全帶扣內，直至聽到咔嚓一聲鎖上為止。
Fasten the insert plastic into the buckle until a "click" sound is heard.
3. 拉動肩帶和中腰帶，確認安全帶已經牢固鎖定。
Pull the shoulder belts and waist belts to check and confirm all are secured.

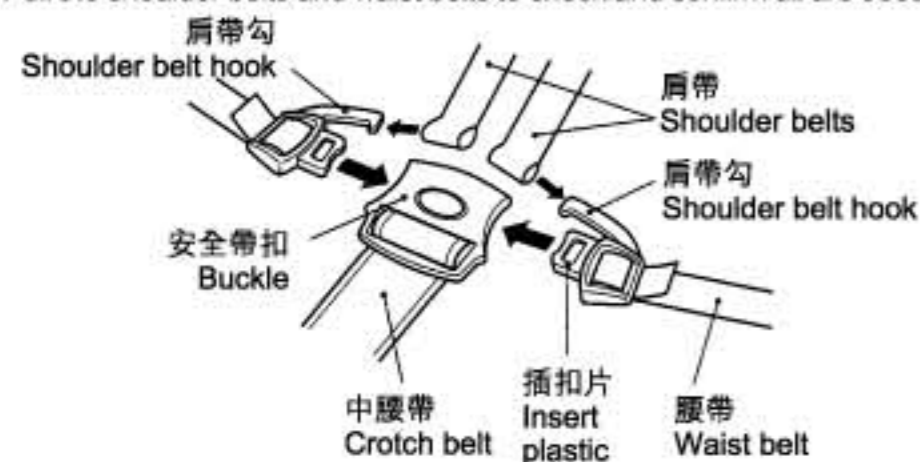

替幼兒穿上安全帶 Fitting seat belt to child

1. 調整靠背至所需角度。
Set backrest to proper angle.
2. 讓幼兒躺下，從兩腿之間抽出安全帶扣。
Seat the child, and pull the crotch belt out of the child legs.
3. 將左右的肩帶分別穿到插扣片上端的肩帶勾上，再將左右插扣片插進安全帶扣內。
Match the left and right shoulder belt to the corresponding shoulder belt hooks on the insert plastics. Fasten the insert plastic into the buckle until it clicks into place.



解除安全帶時 To release seat belt

按下安全帶扣的按鈕。
Press on the buckle button.

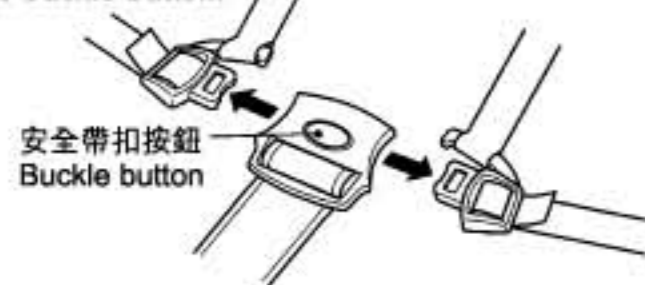

- 調節安全帶至適當長度，以免幼兒跌出。
Adjust the seat belt to proper length. Otherwise the child may fall off the chair.
- 如調節安全帶長度時解下插扣片，請參照P.19「安裝插扣片到腰帶上」重新安裝。
In case the insert plastics have been released while adjusting the seat belt, please restore the insert plastics properly referring to P.19 Attaching the insert plastics to the waist belts.
- 有關安全帶的使用方法請參照P.2「使用方法一覽表」。
Refer to P.2 "Guidelines to use" for proper usage of seat belt.

使用安全帶 (腰帶、中腰帶、肩帶) Using the seat belt (waist belt, crotch belt, shoulder belt)

調節安全帶長度 Adjusting the length of seat belt

警告 WARNING

- 請配合幼兒體形調節安全帶至適當長度，以免使用時幼兒意外跌落。
Adjust the seat belt to proper length according to child's body size. Otherwise the child may fall off the chair during use.
- 每次改變靠背角度時，請重新調節安全帶，以免使用時幼兒意外跌落，而令鬆脫的安全帶纏在幼兒頸項之上。
Re-adjust the seat belt again every time after changing the backrest angle. Otherwise the child may fall off accidentally while using the chair, and may get caught around by the seat belt.
- 調節後嘗試拉動肩帶和中腰帶，確認安全帶已經鎖定。
Try to pull the seat belt to check if they are secured.
- 使用平躺靠背角度時，必須使用肩帶。
Shoulder belt must be used for the most reclined angle.
- 請配合幼兒體形調節各種安全帶至適當長度。
Adjust the length of each belts according to child's body size.

調節腰帶長度 Adjusting the length of waist belt

插扣片上的腰帶穿孔
insertion outlet



1. 將腰帶前端由穿孔①解下，將希望調節的①部份拉出。
Release the waist belt end from the insertion outlet (a), and pull out the length (1) to be adjusted toward the illustrated direction.
2. 將腰帶拉往左或右調節長度。延長時向②方向拉，縮短時則往③的方向拉動。
Pull the waist belt to the left or right to adjust the length. Pull toward direction (2) when extending the belt and (3) when shortening the belt.
3. 將腰帶前端重新穿過穿孔①。
Restore the waist belt end back to insertion outlet (a).

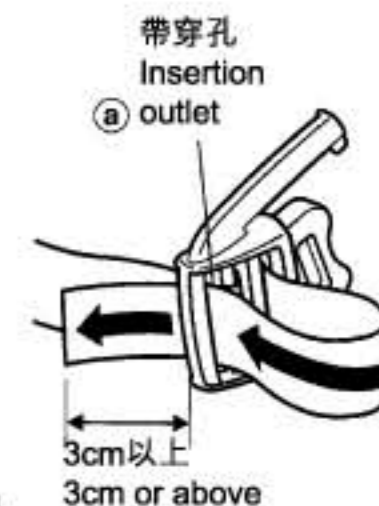

注意腰帶末端應預留下3cm以上之長度。
Make sure to leave at least 3cm at the end of the belt.

調節中腰帶長度 Adjusting the length of crotch belt

1. 將中腰帶套翻上來，以調節中腰帶的長度。
Remove the crotch belt cover from the crotch belt before adjusting the crotch belt.
2. 將希望調節的①部份拉出。
Pull out the length (1) to be adjusted toward the illustrated direction.
3. 延長時向②方向拉，縮短時則往③的方向拉動。
Pull toward direction (2) when extending the belt and direction (3) when shortening the belt.

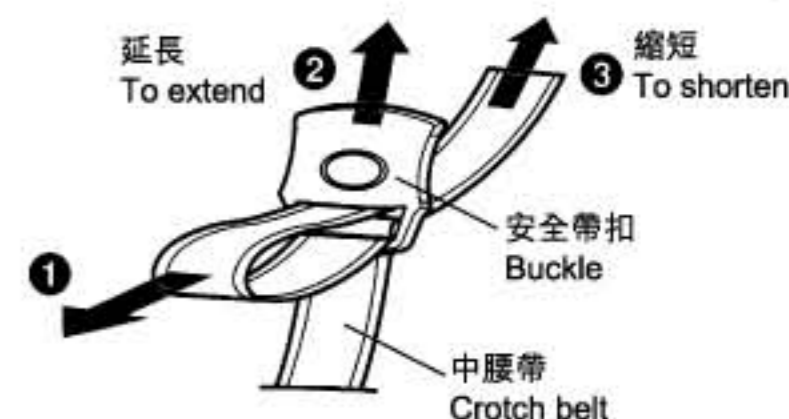

調節肩帶長度 Adjusting the length of shoulder belt

1. 將椅墊取出來，露出靠背上的肩帶穿孔。
Lift the seat cushion and expose the shoulder belt insertion outlets on the backrest.
2. 先將①部份從靠背表面拉出調節。
Pull out the length ① to be adjusted toward the illustrated direction.
3. 若延長時向②方向拉，縮短時則往③的方向拉動。
Pull toward direction ② when extending the belt and direction ③ when shortening the belt.

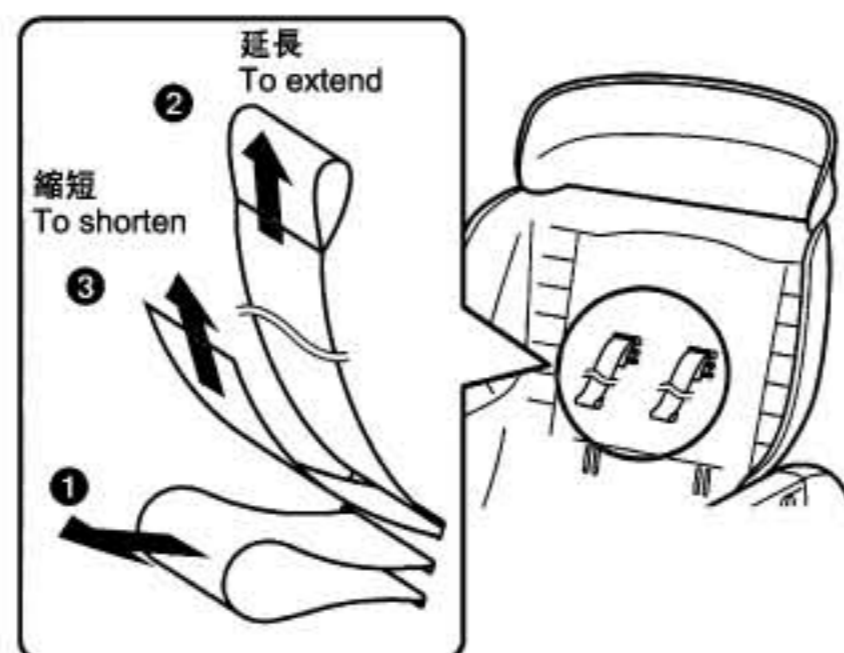

警告WARNING

按照美國 ASTM 安全標準：
As according to ASTM standard：
在任何時間幼兒使用此餐椅時應確保扣好安全帶，不論椅背平躺位置或挺直位置。本小桌設計不是用作固定幼兒在餐椅上。當椅背固定於挺直位置時，建議只讓能挺直坐的幼兒使用。
THE CHILD SHOULD BE SECURED IN THE HIGH CHAIR AT ALL TIMES BY THE RESTRAINING SYSTEM, EITHER IN THE RECLINING OR UPRIGHT POSITION. THE TRAY IS NOT DESIGNED TO HOLD THE CHILD IN THE CHAIR. IT IS RECOMMENDED THAT THE HIGH CHAIR BE USED IN UPRIGHT POSITION ONLY BY CHILDREN CAPABLE OF SITTING UPRIGHT UNASSISTED.

- 每次改變斜躺角度時，肩帶長度將會改變。請重新調節安全帶。
Shoulder belt length may change upon changing of recline position. Re-adjust the seat belt again every time after changing the recline angle.



- 安全帶和幼兒之間，應可放進一隻成人手指左右的寬度。
Leave a gap of around an adult's finger in between the seat belt and the child's body.



- 不使用肩帶時，請收起於椅墊內。
Store the shoulder belts underneath the seat cushion when not in use.

收起於椅墊內
Store underneath the seat cushion



安裝小桌 Attaching the table

小桌可配合幼兒成長，前後作出三段調節。

Table can be adjusted to 3 different positions according to child's growth stage.

警告WARNING

- 提起餐椅時，請勿手執小桌搬動，以免小桌意外鬆脫令主體跌落。
Do not hold on the table when lifting the chair. Otherwise the table may get detached accidentally and cause the chair to fall off.
- 設計小桌的目的是不能固定幼兒的，請使用安全帶。
Table cannot secure the child on the chair so please use seat belt.
- 請小心看護幼兒，切勿令幼兒將手指伸進主體側面上的槽溝內引致受傷。
Do not let child expose its fingers in slots at the main body. Otherwise they may get pinched.
- 請勿站在小桌上，或拍打小桌，以免引致餐椅損壞。
Do not stand on the table or hit the table. Otherwise damage may be caused to the chair.
- 請配合幼兒成長作出適當調節小桌的位置。
Adjust the table position to fit the child's body.

1. 將小桌兩側的小桌鎖往外側拉。
Pull out the table lock on each side.
2. 對準準主體側面的小桌插槽將小桌放入。
Match with the slots on the main body and insert the table.
3. 小桌可作出三段調節。
Table can be adjusted to 3 different positions.
4. 輕輕前後搖動小桌，確認牢固後才開始使用。
Make sure the table is well secured by slightly move before use.

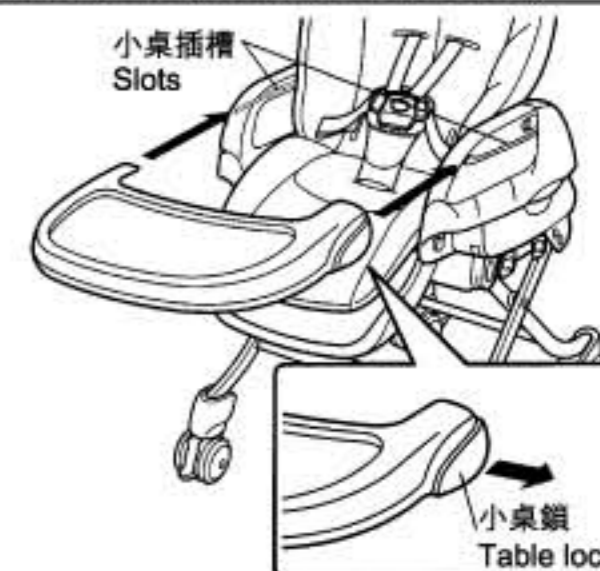

拆除小桌 Detaching the table

拆除小桌時，將左右兩方的小桌鎖往外拉出，便能拆除小桌。
Pull out the table lock on each side to remove the table from the chair.

嬰兒用品箱 Storage box

嬰兒用品箱可以收藏紙尿片或抹布等物件。要存放較大型紙尿片時，請改變內裡間隔使用。嬰兒用品箱可從主體拆下分開使用的。

Storage box can be used to store diapers or wipes. Partition can be changed to fit larger diapers etc.. Storage box can be removed from main body and use separately.



注意 CAUTION

- 如不使用時請經常關上箱蓋，以免誤踏引致危險。
Always close the storage box when not in use to prevent stepping on the lid accidentally.
- 當提起主體移動時，請先拆除嬰兒用品箱，以免嬰兒用品箱意外鬆脫掉落。
Always remove the storage box before moving the main body in case the box may get loosen to fall off from moving the chair.
- 必須保持嬰兒用品箱關閉。
Always keep the storage box closed.
- 請勿將體重加在嬰兒用品箱上。
Do not add on your body weight onto the box.
- 請勿存放1.5kg以上之物件放進箱內。
Do not store more than 1.5kg into the storage box.
- 請勿在主體摺合的狀態下使用嬰兒用品箱。
Do not use the storage box when folded the main body.

1. 將嬰兒用品箱背面的掛鉤，先插進主體側面的掛鉤大孔內。
Plug the hooks on the back of the storage box to the bigger left holes of the slots on the side of the main body.
2. 將嬰兒用品箱往右下方滑動鎖上。
Slide the storage to the lower right to secure it.

拆除嬰兒用品箱 Detaching the storage box

一邊手執嬰兒用品箱，一邊將嬰兒用品箱往左方滑動拔出。
Hold the storage box and slide it to the left and remove it from the main body.



調節斜躺角度 Adjusting the recline angle

靠背跟腳踏是連動式設計的，可調節至5個角度。
The backrest is designed interlocking with the step and can be adjusted to 5 different angles.

請注意
Please note 請將靠背設置最平躺角度，讓剛出生的初生嬰兒或頸部還未完全發育的幼兒(約2-3個月大)使用。
Please use the most reclined angle for baby from new born to around 2 ~ 3 months old baby, whose neck muscle is not yet developed.

警告 WARNING

- 調節靠背的角度後，必須重新調節安全帶的長度，以免幼兒意外跌出座椅而令安全帶纏住幼兒頸部而構成危險。
Re-adjust the seat belt again after changing the recline angle. Otherwise the child may fall off accidentally while using the chair, and the seat belt may get caught around child's neck when slipping.
- 調節斜躺角度必須使用斜躺調節杆。
Use the recline adjustment lever when adjusting the backrest position.

注意 CAUTION

- 除調節斜躺角度以外，必須鎖上靠背鎖。
Keep the recline lock secured except when adjusting the backrest position.
- 調低靠背時，連動的腳踏會向前伸出。操作前請確認餐椅前方沒有障礙物。
The interlocked step will extend to the front automatically when lowering the backrest. Check beforehand that there is not obstacle in front of the chair.

警告 WARNING

按照美國 ASTM 安全標準：
As according to ASTM standard：
在任何時間幼兒使用此餐椅時應確保扣好安全帶，不論椅背平躺位置或挺直位置。本小桌設計不是用作固定幼兒在餐椅上。當椅背固定於挺直位置時，建議只能讓挺直坐坐的幼兒使用。
THE CHILD SHOULD BE SECURED IN THE HIGH CHAIR AT ALL TIMES BY THE RESTRAINING SYSTEM, EITHER IN THE RECLINING OR UPRIGHT POSITION. THE TRAY IS NOT DESIGNED TO HOLD THE CHILD IN THE CHAIR. IT IS RECOMMENDED THAT THE HIGH CHAIR BE USED IN UPRIGHT POSITION ONLY BY CHILDREN CAPABLE OF SITTING UPRIGHT UNASSISTED.

- 1** 先將靠背鎖的鎖定狀態解除。
Turn the recline lock to release the backrest.



- 2** 一邊用手扶著靠背，一邊將斜躺調節杆往後方拉。
Hold the backrest with one hand and pull out the recline adjustment lever.



- 3** 拉下靠背，選擇要使用的角度。
Lower the backrest to the preferred position.

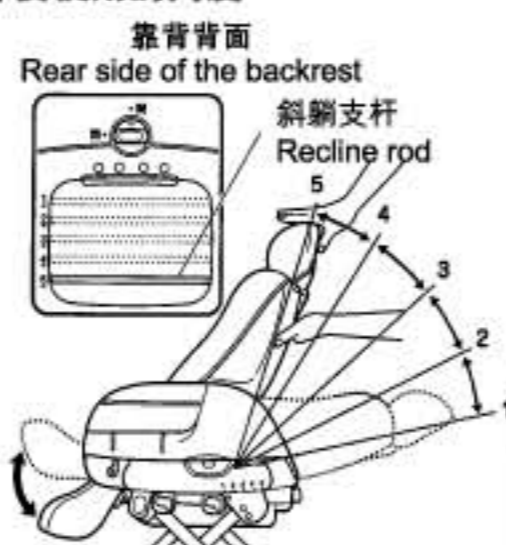

請確認斜躺支杆已經卡在溝槽之中。
Make sure the recline rod clicks into place.

- 4** 按回斜躺調節杆，將靠背鎖復原至鎖定狀態。
Restore the recline adjustment lever, turn and lock back the recline lock.



13

使用搖椅功能 Using as a rocking chair

搖椅功能能夠讓幼兒更舒適地安躺在椅中。使用搖椅功能時，必須鎖上方向輪。
Rocking function can provide a comfortable environment to the child. Lock the swivel wheels when using as a rocking chair.

警告 WARNING

切勿讓幼兒將搖椅當作鞦韆般使用，以免引致意外翻倒或掉落。
Do not allow child to play the rocking chair as a swing. Otherwise the chair may tip over and cause the child to fall off.

注意 CAUTION

- 對於剛出生的初生嬰兒至頸部還未完全發育的幼兒(約2-3個月大)使用搖椅功能時請將靠背設置在最平躺的位置。
Use as a rocking chair with a full reclined backrest for a new born to 2 ~ 3 months old baby whose neck muscle is not yet developed.
- 哺乳後30分鐘以內切勿使用搖椅功能，以免嬰兒吐奶。
Do not use as a rocking chair in 30 minutes after feeding that may cause the baby to vomit.
- 使用搖椅功能時，注意嬰兒的反應。如果發覺任何異常情形，請立刻中止使用。
Pay attention to the baby when using as a rocking chair. Stop using immediately when any abnormal situation is found.
- 使用搖椅功能時搖椅主體會作前後方向的擺動。請先確認搖椅前後沒有障礙物後才開始使用。
The main body will swing forward and backward when using as a rocking chair. Make sure there is no obstacle near the chair before use.
- 切勿在餐椅摺疊的狀態使用搖椅功能。
Do not use the rocking function in the folded position.

- 1** 按下4個方向輪鎖，將方向輪鎖定。
Press down the 4 swivel locks to lock the swivel wheels.



- 2** 將靠背設定在平躺角度(1或2)。
Set the backrest at the reclined position (1 or 2).

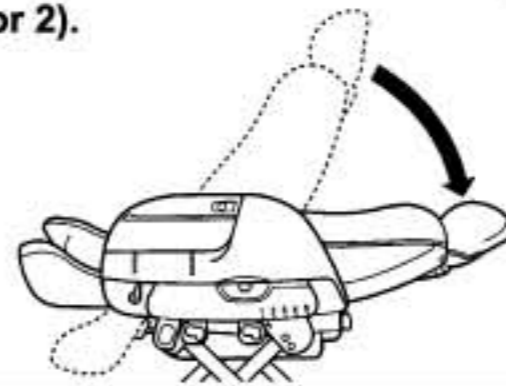

詳情請參閱P.13「調節靠背角度」。
Refer to P.13 "Adjusting the backrest angle".

- 3** 讓幼兒躺下，扣上安全帶。
Seat the child and fasten the seat belt.

- 4** 將靠背下方的搖椅鎖拉出作解除。
Pull out the rocking chair lock on the lower side of the backrest and release it.



- 5** 用手按著靠背慢慢搖動主體。
Push the backrest slowly and gradually.

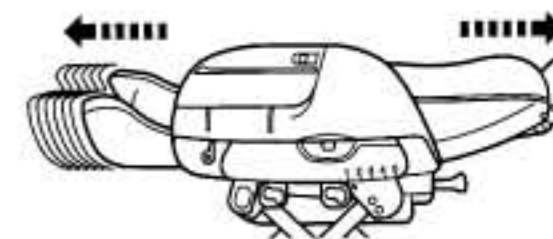

不使用搖椅功能時，將搖椅鎖按回鎖定位置。
Restore the rocking chair lock when the rocking function is not in use.

14

使用嬰兒架 Using the baby pallet

單觸式側護欄開放設計，方便騰出空間替幼兒更換紙尿片等。

One-touch side guard design providing more space for child changing of diapaers and etc..

嬰兒架是供幼兒更換紙尿片或替換衣服時使用的。

Baby pallet is to be used for changing diapers or clothes for baby.

使用嬰兒架前，請先將靠背設置在最平躺的位置。

Set the backrest at the most reclined angle before using the baby pallet.



⚠ 注意 CAUTION

- 請勿承載1kg以上的物件在嬰兒架上，以免引致損壞。
Do not place more than 1kg onto the baby pallet. Otherwise damage may be caused to it.
- 移動餐椅時，請勿手執未鎖上的嬰兒架，以免引致損壞。
Do not hold on an unsecured baby pallet when lifting the chair. Otherwise damage may be caused to it.
- 請勿讓幼兒操作嬰兒架，以免意外夾傷手指等。
Do not allow the child operate the baby pallet. Otherwise the child's fingers etc. may get pinched accidentally.
- 打開嬰兒架後，切勿讓幼兒攀上嬰兒架，或將身體倚靠在嬰兒架上。
Do not allow the child climbing over the baby pallet or leaning its body onto the baby pallet.
- 除幼兒更換紙尿片或替換衣服時以外，請勿打開嬰兒架。
Keep the baby pallet closed except when changing diapers or clothes etc..
- 不使用嬰兒架時，請確保嬰兒架經已鎖上。
Keep the baby pallet closed when not in use.
- 操作嬰兒架時，請小心以免意外夾傷幼兒。
Be careful not to pinch the child when operating the baby pallet.

使用嬰兒架時 To use the baby pallet

- 1** 將靠背設定在最平躺的位置。
Set the backrest at the most reclined position.

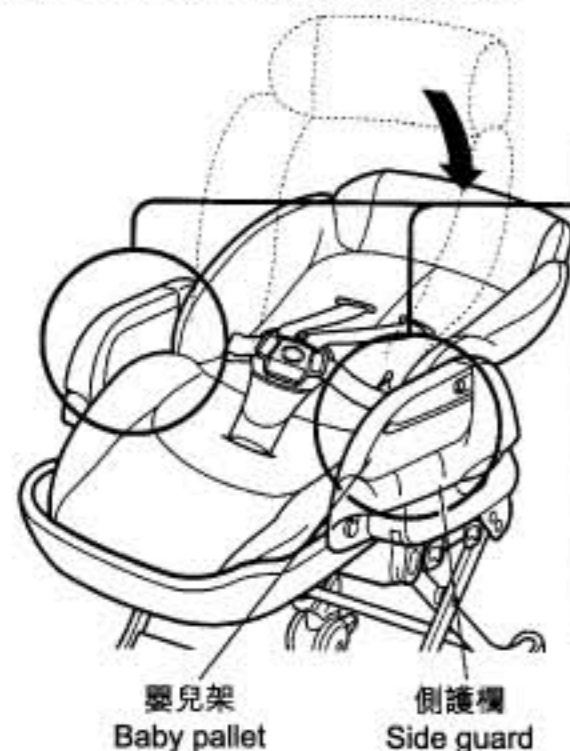

- 2** 將嬰兒架鎖杆拉出，將嬰兒架打開。
Pull out the baby pallet lock and open the baby pallet.

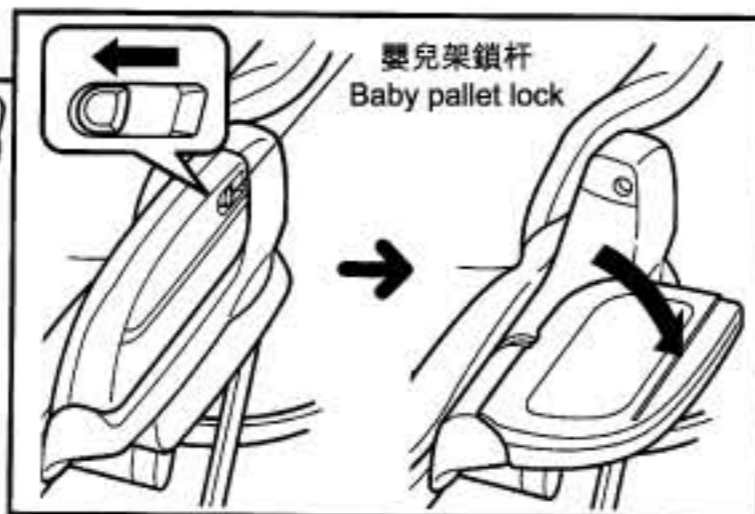

收起嬰兒架時 To restore the baby pallet

如要收起嬰兒架，將嬰兒架復原至原來位置。

Restore the baby pallet to its stored position when not in use.

將嬰兒架如圖般往箭咀方向拉至「咔嚓」一聲重新鎖上。
Baby pallet clicks into place.



使用收合杆 Using the folding lever

餐椅摺疊後體積細小，方便收藏。

The chair can be folded to a compact size for easy storage.

⚠ 警告 WARNING

當幼兒正在使用時，請勿操作收合杆，以免令幼兒意外掉落。

Do not operate the folding lever when it is in use. Otherwise it may cause the child to fall off accidentally.

⚠ 注意 CAUTION

- 操作收合杆前，請先拆除嬰兒用品箱。
Remove the storage box before folding the chair.
- 切勿在餐椅摺疊的狀態使用搖椅功能。
Do not use the rocking function when the chair is in folded position.
- 操作收合杆作調低餐椅高度時，小心意外夾傷手腳等。此外，由於操作時腳輪會前後移動，請小心注意腳邊的安全。
Beware of your hands and etc. when folding the chair. Also, beware your feet in case the wheels may move forward or backward when folding the chair.
- 請勿在摺疊的狀態移動餐椅，以免刮花地面。
Do not drag the folded chair to the floor. Otherwise damage maybe caused to the floor.

- 1** 將靠背設置在最平躺的位置。
Set the backrest at the most reclined position.
- 2** 將方向輪鎖定。
Secure the swivel wheels.
- 3** 將主體高度調至最低。
Set the height of main body to the lowest position.

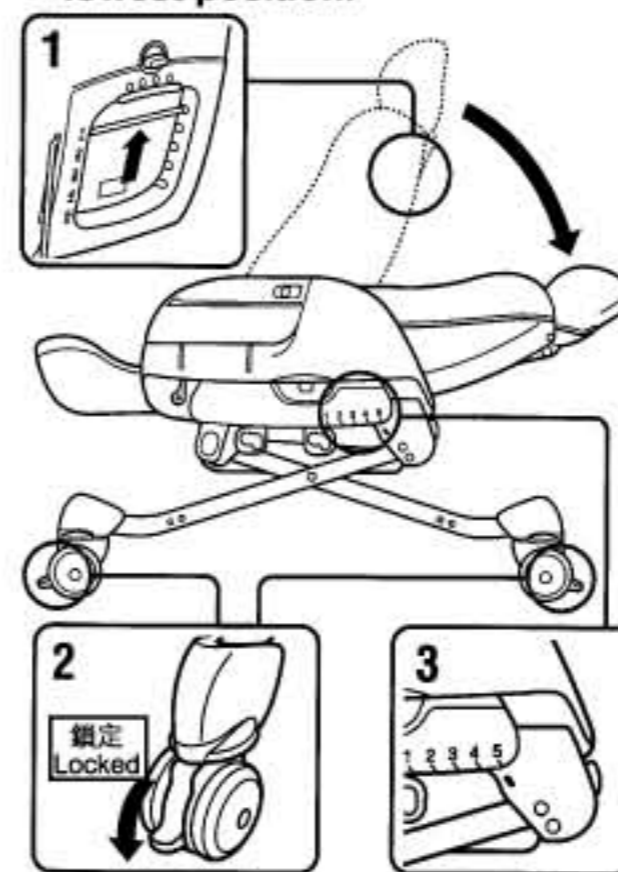

- 詳情請參閱P.13「調節斜躺角度」。
Refer to P.13 "Adjusting the recline angle"
- 詳情請參閱P.7「調節餐椅高度」。
Refer to P.7 "Adjusting height of chair"
- 詳情請參閱P.8「使用方向輪」。
Refer to P.8 "Using the swivel wheels"

- 2** 一邊手執腳踏，一邊分別將兩側的收合杆如圖般向己方轉動解除。
Hold on the step and to release the folding levers on the left and right respectively.

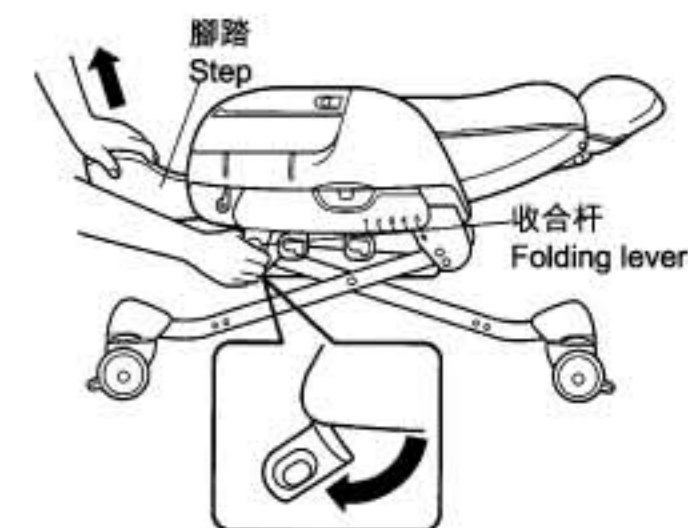

- 3** 慢慢放下主體。
Lower the main body slowly.

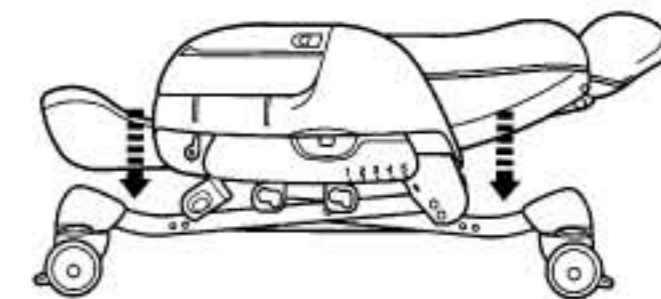

當重新使用餐椅時，再度使用餐椅時，把左右設置在兩端側護欄下方的高度調節杆，由下往上按然後提起主體至所需高度。
When using the chair again, press on the left and right height adjustment lever underneath the side guard and lift the main body up to a preferred position.

椅墊和安全帶的安裝/拆除 Attaching/removing seat cushion and seat belt

警告 WARNING

- 使用餐椅時必須安裝椅墊，以免餐椅上的夾縫意外夾傷幼兒手脚。
Do not use a chair without seat cushion. Child's hands and feet may get pinched by the gaps from the chair.
- 使用前請確保安全帶已經正確裝好，以免使用時安全帶突然鬆脫，引致意外發生。
Make sure seat belts are properly attached before use. Otherwise seat belt may get loosen suddenly and become the cause of accident while in use.
- 錯誤安裝可能會引致幼兒使用時意外掉落。
Improper installation may cause the child to fall off while in use.
- 安裝安全帶後，請拉動帶端確保沒有鬆脫。
Pull at each belt end to make sure all belts are secured.
- 幼兒突如其來的動作，即使已扣上安全帶也有可能令其跌出餐椅。請小心看顧幼兒。
Child's unexpected acts may cause it to fall off the chair. Pay attention to child even when seat belt is being used.



拆除方法 To remove

- 1 將靠背設定在最直立位置，按下安全帶扣上的按鈕解除肩帶。
Set the backrest at most upright position. Press on the belt buckle to release the shoulder belt.

詳情請參閱P.13「調節斜躺角度」。
Refer to P.13 "Adjusting the recline angle"

- 2 將腰帶從插扣片上拆除，然後從中腰帶上拆除中腰帶套。
Release the insert plastics from the waist belt and then the crotch belt cover from the crotch belt.

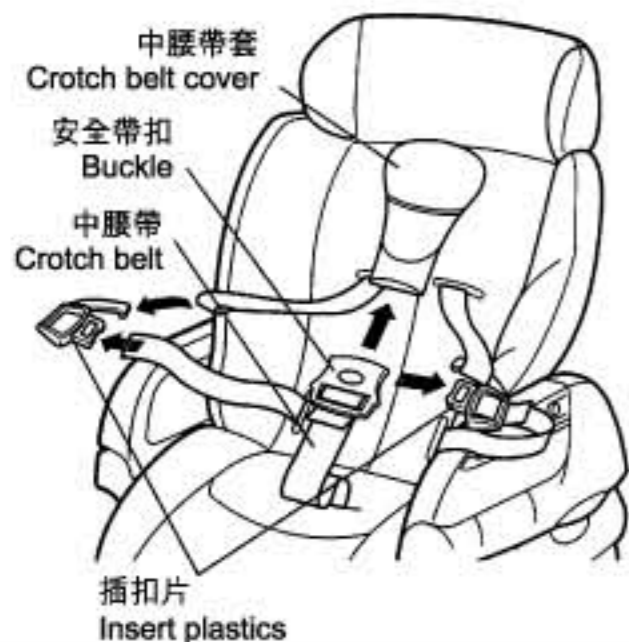

注意 CAUTION

安全帶扣是不能從中腰帶拆除。
Buckle is not removable from the crotch belt.

- 3 拆除椅墊。
Remove the seat cushion.
解除①腳踏上的2個鈕扣，然後解除②主體中央的2個掛鉤和2個鈕扣。
Release ① the 2 snaps on the step and then ② the 2 hooks and 2 snaps on the main body.

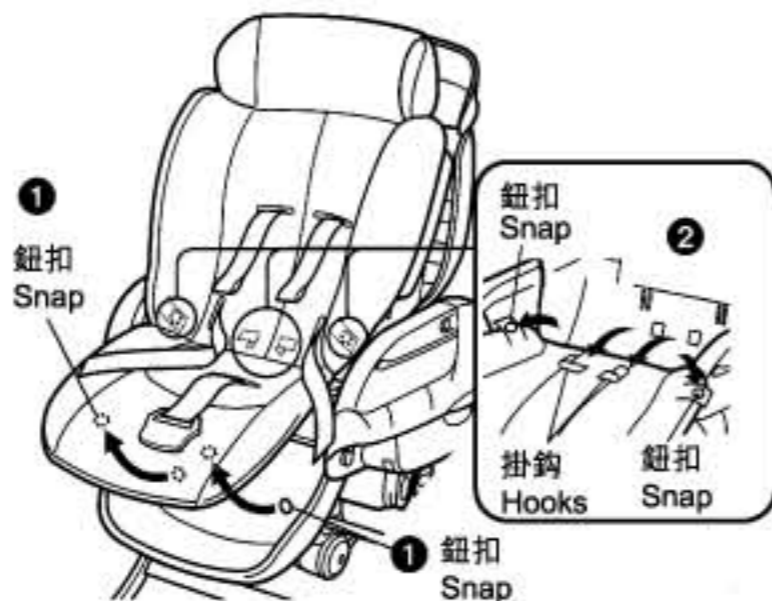

- 4 將安全帶往椅墊背面抽出，然後將椅墊從主體拆除。
Remove the seat belt from the back of seat cushion. Detach the seat cushion from the main body.



椅墊和安全帶的安裝/拆除 Attaching/removing seat cushion and seat belt

- 4 將肩帶、腰帶和中腰帶分別從主體拆除。
Remove the shoulder belt, waist belt and crotch belt respectively from the main body.

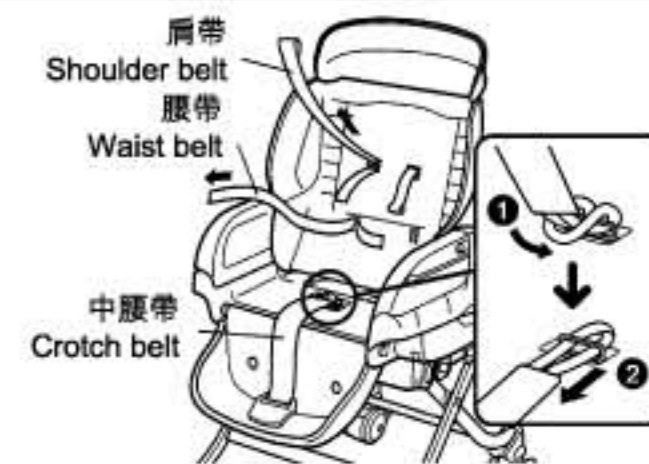

安裝方法 To attach

- 1 將靠背設定在最直立位置。
Set the backrest at the most upright position.

詳情請參閱P.13「調節斜躺角度」。
Refer to P.13 "Adjusting the recline angle".

- 2 將肩帶、腰帶和中腰帶分別安裝到主體上。
Attach the shoulder belt, waist belt and crotch belt respectively to the main body.

安裝腰帶和中腰帶 To attach the waist belt and crotch belt

1. 如圖般將腰帶一端穿過主體上的穿孔並抽出，然後再同樣穿過第二個穿孔。
As illustrated, pull the waist belt through the slots on the main body to the back, and then pull out to the front. Then pull it to the back again the second time.
2. 將腰帶左右兩端調節成相同長度。
Adjust the left and right waist belts to the same length.
3. 將中腰帶末端的幼帶環穿過中腰帶掛鉤，再將中腰帶穿過帶環。
Pull the ring-shape belt end of the crotch belt through the crotch belt hook, and then pull the crotch belt itself through the ring-shape belt end.

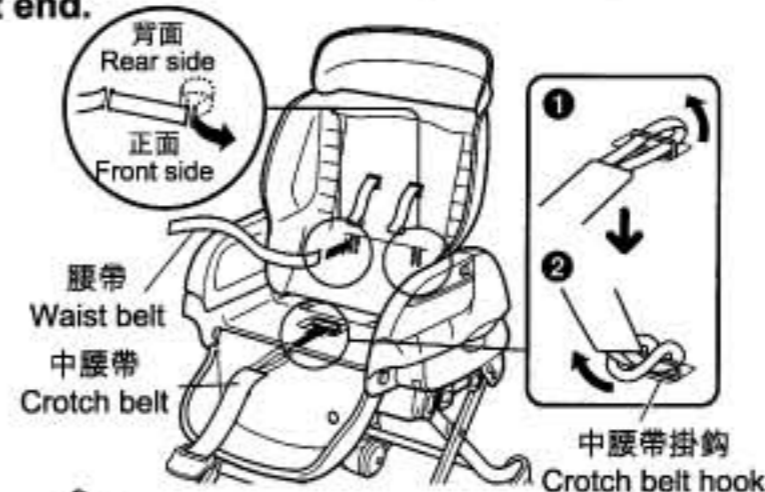

詳情請參閱P.10「調節安全帶長度」。
Refer to P.10 "Adjusting the length of seat belt".

安裝肩帶 To attach the shoulder belt

確認肩帶的正面和背面。有縫接口的一端為正面。安裝時小心帶端的縫接口。
Confirm the front and rear side of shoulder belt. The side with stitching is the front side. Beware of the stitches when attaching the shoulder belt.

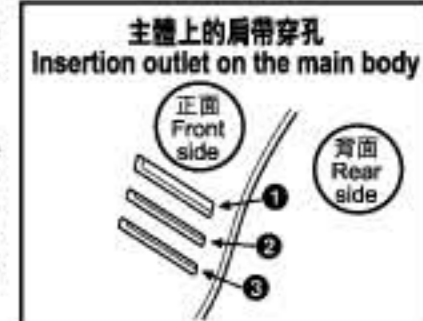

1. 從主體正面將肩帶穿過①穿孔到背面。將背面的帶端從③穿孔穿回正面，再復穿過②穿孔到背面。
Pull the shoulder belt through the insertion outlet ① to the back. Then pull the belt end from the back to the front through insertion outlet ③ and then through the outlet ② again to the back.
2. 將帶端從①穿孔穿回正面。
Pull the belt end through insertion outlet ① to the front.
3. 將肩帶左右兩端調節成相同長度。
Adjust the left and right shoulder belts to the same length.

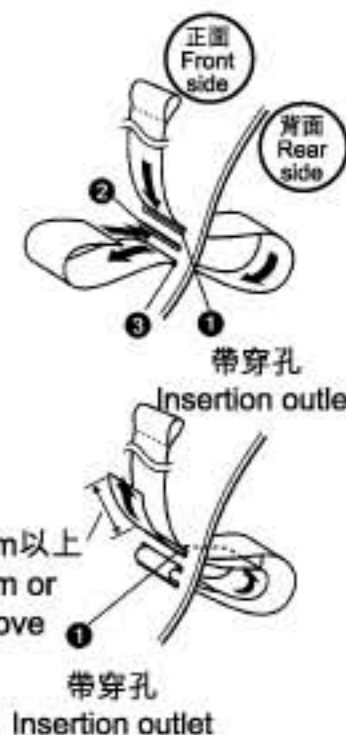

詳情請參閱P.11「調節肩帶長度」。
Refer to P.11 "Adjusting the length of shoulder belt".

3

將椅墊套上。
Cover the seat with the seat cushion.

- 將安全帶抽出椅墊正面。
Pull the seat belt to the front side of the seat cushion.

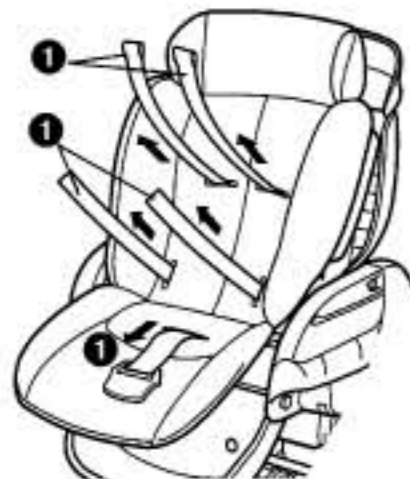

- 將主體中央的2個掛鉤和帶扣穿過主體兩側的圓孔(2處)，扣上，再扣上 腳踏的2個鈕扣。
Secure the 2 hooks on the main body and then the 2 belt snaps through the side holes (x 2) on the main body. Secure the snaps, and then secure the 2 snaps on the step.
- 將椅墊套上。
Cover the seat with the seat cushion.

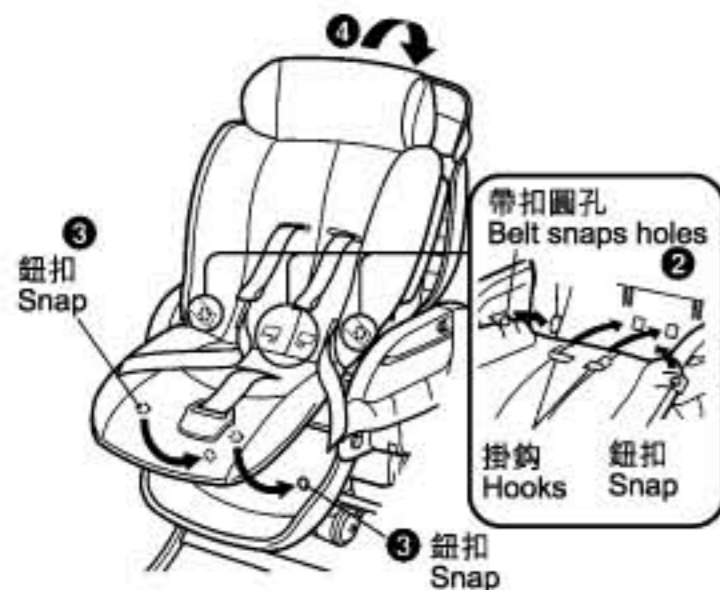

4

將插扣片裝到腰帶上。
Attach the insert plastics to the waist belts.

插扣片上的腰帶穿孔
Slots on the insert plastics



1. 從插扣背面將腰帶穿過(a)穿孔到正面。
Pull the waist belt from the back to the front through slot (a).



2. 將正面的帶端從(b)穿孔穿回背面。
Pull the waist belt again to the back through slot (b).

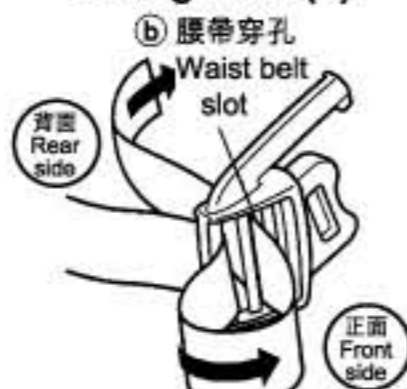

3. 再從背面復穿過(c)穿孔到正面。
Pull the waist belt to the front again through the slot (c).



4. 帶端從(a)穿孔穿回背面。
Set the belt end to the back through slot (a).

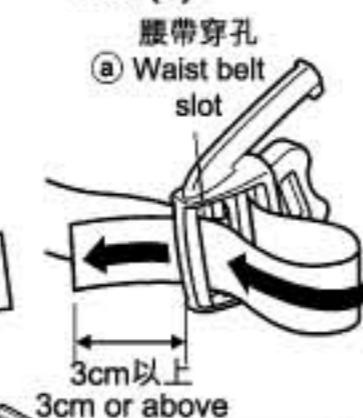

調節腰帶時注意腰帶末端應預留3cm以上長度。
Adjust the waist belt and make sure to leave at least 3cm at the end of the belt.

5

安裝中腰帶套到中腰帶上。
Cover the crotch belt with the crotch belt cover.



6

將左右的肩帶分別穿到插扣片上端的肩帶掛鉤上。將左右插扣片插進安全帶扣，直至聽到咔嚓一聲鎖定為止。

Match the left and right shoulder belt to the corresponding shoulder belt hooks on the insert plastics. Fasten the insert plastic into the buckle until a "click" sound is heard.

有關安全帶各部之名稱，請參閱P.9「使用安全帶(腰帶、中腰帶、肩帶)」。
Refer to P.9 "Using the seat belt (waist belt, crotch belt, shoulder belt)" for names of each part of the seat belt.

清潔座面 Cleaning of seat base

清潔座面上的污垢時，先拆除椅墊，將靠背設定在直立角度。落在通風口下方的塵埃，可以掃往主體後方。
Remove the seat cushion first to clean the seat base. Set the backrest at the most upright position. Wipe the dirt underneath the ventilation window to the rear side.

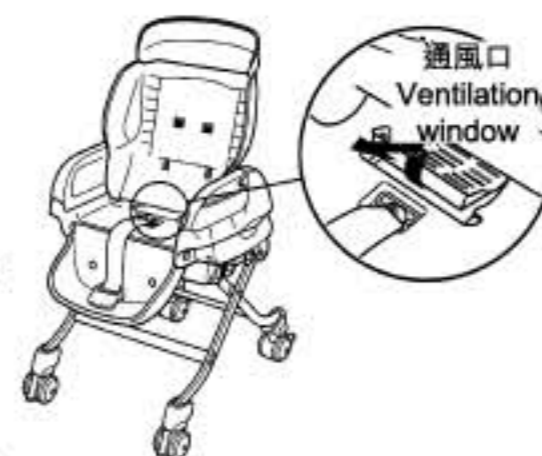

清潔主體 Cleaning the main body

注意 CAUTION

請勿使用未經稀釋的中性清潔劑原液、汽油或其他有機溶劑進行清潔，以免對主體造成損壞。
Do not use undiluted neutral detergent, gasoline or other organic agents to clean the main body frame. Otherwise damage may be caused to the main body.

- 以溫水或稀釋了的中性清潔劑浸濕抹布，扭乾後拭抹主體上的塵埃。
Wipe off dirt with a piece of damp cloth after soaking it with warm water or diluted neutral detergent.
- 車輪或方向輪鎖沾著塵埃後會變滑。用稀釋了的中性清潔劑浸濕抹布，扭乾後拭抹塵埃。
Wheels or swivel wheel locks may get slippery with dirt. Wipe off dirt with a piece of damp cloth after soaking it with diluted neutral detergent.

椅墊、中腰帶套、中腰帶、肩帶和腰帶的保養 Cleaning the seat cushion, crotch belt cover, crotch belt, shoulder belt and waist belt

手洗い 30	以30度以下溫水手洗。 Hand wash in water with a maximum temperature of 30 degree.
	切勿使用漂白劑。 Do not bleach.
	切勿使用熨斗。 Do not iron.
	切勿乾洗。 Do not dry clean.
	切勿扭捏，以免留下皺褶。 Do not twist or wring. Wrinkle may be left when strongly twisted.
	請放在陰涼處晾乾。 Flat dry in shaded area.

- 拆下椅墊，依照以上洗滌指示進行清洗。
Detach the seat cushion and wash according to the washing instructions.
- 中腰帶請和安全帶扣一起清洗。(安全帶扣是不能拆除的)
Wash the crotch belt together with the buckle (buckle is non-detachable from the belt).
- 本製品特性上會有可能輕微脫色。
The fabric may experience a little decoloring according to the material characteristic.
- 建議使用不含螢光劑、漂白劑和酵素的天然清潔劑清洗。
It is recommended to wash with neutral detergent which does not contain fluorescent brightener, bleach and etc.
- 建議和其他衣物分開清洗和脫水。
It is recommended to wash and spin separately with other clothes.
- 請徹底進行沖水程序。
Rinse thoroughly.
- 小心洗滌，確保使用時更舒適。
Frequently washing is advised for comfortable use.
- ※ 不能使用一般洗衣袋。請使用專用洗衣袋。
Do not use normally washing bag. Use special washing bag only.

注意 CAUTION

進行日常保養時拆下的部品，請按照本說明書正確重新裝上。
Restore each part properly after cleaning according to the instruction manual.

保存方法
Storage

注意 CAUTION

不要存放在火源附近，或高溫的地方。此外，避免在上面置放重物或加以壓力，以免引致主體故障或變形。
Do not store the chair under high temperature or near a heat source. Also, not load any heavy items on the chair. Otherwise the main body may get deformed or damage may be caused to the main body.

如有疑問請向經銷商查詢
Please contact local distributor for enquiries.

Combi

www.combibaby.com.tw