

Combi

SUGOCAL Light



EN Instruction manual

繁體中文 說明書

SUGOCAL Light

ENGLISH Instruction manual 7

繁體中文 使用說明書 18

List of components (Please refer P13)

部件名稱 (詳見 P22)

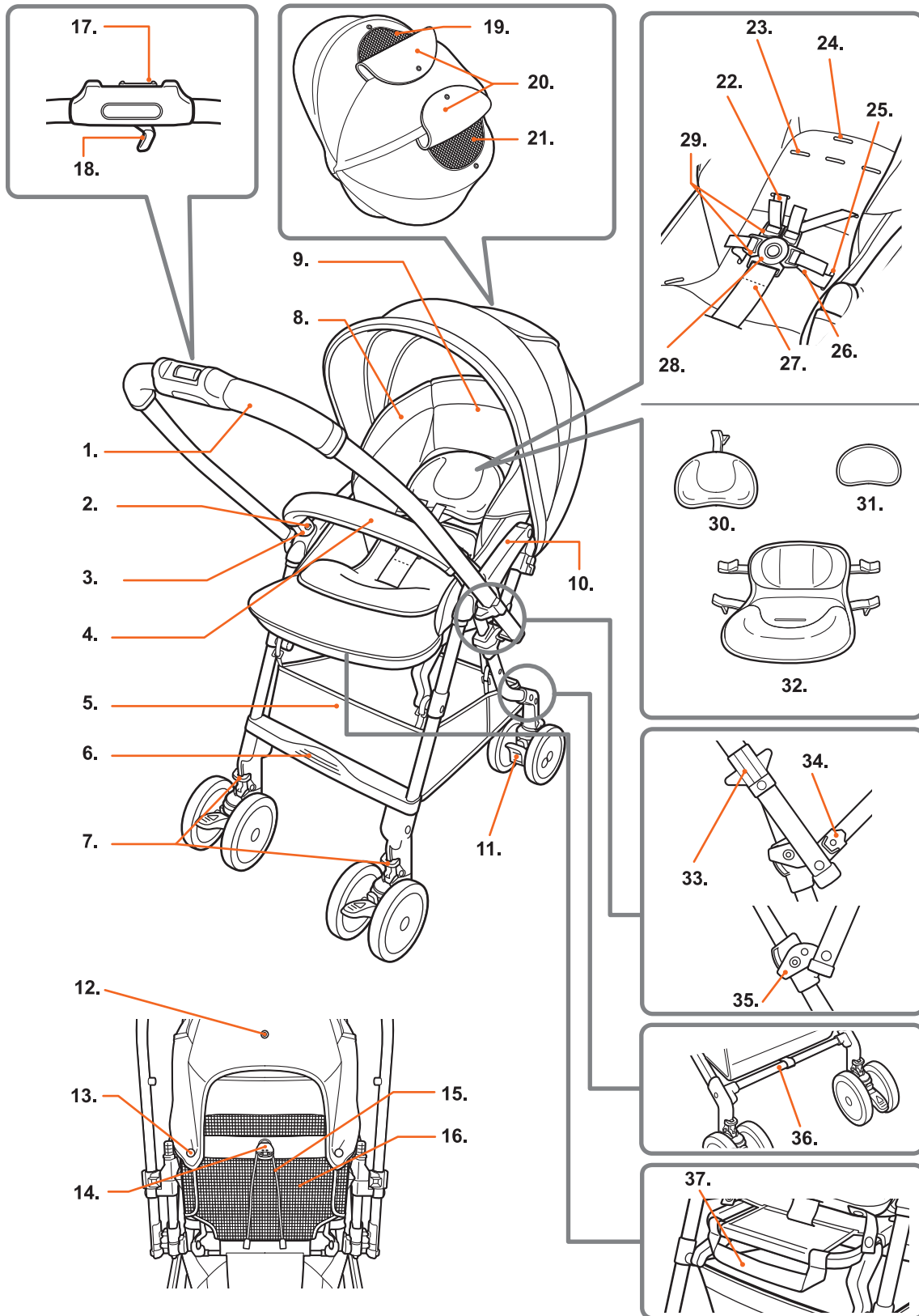

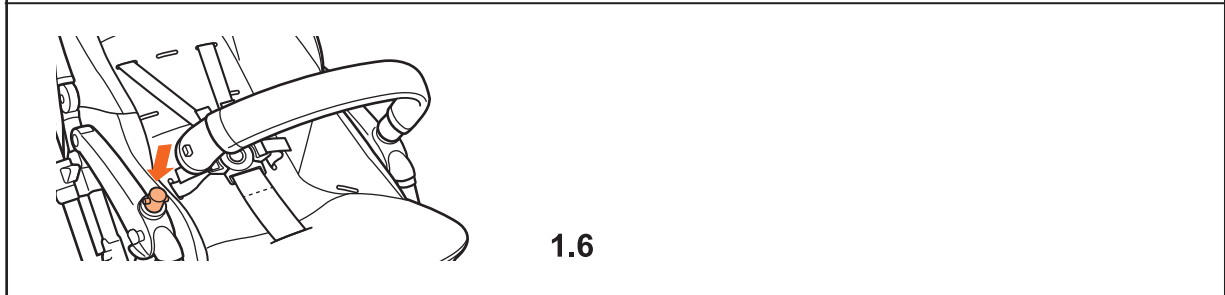
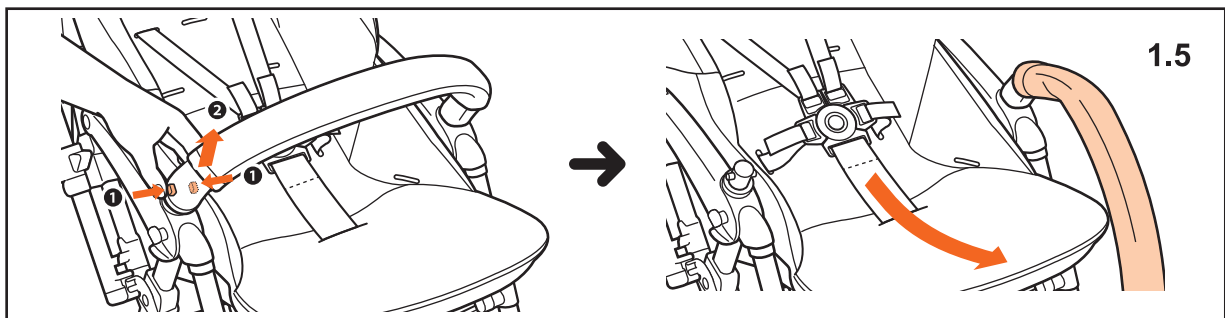
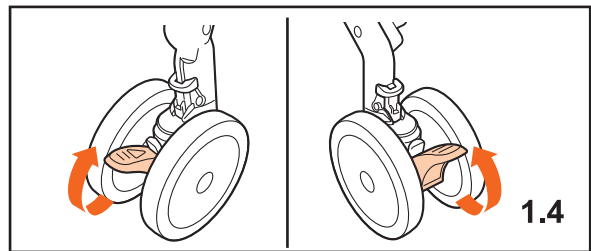
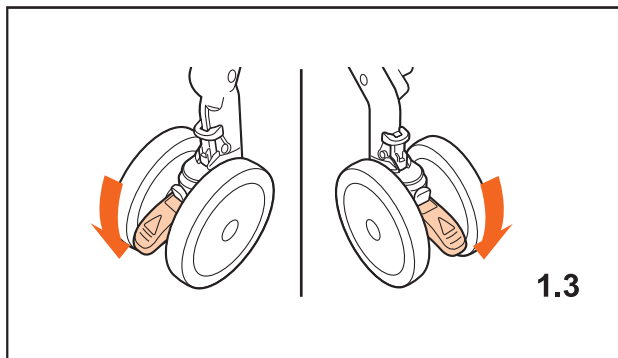
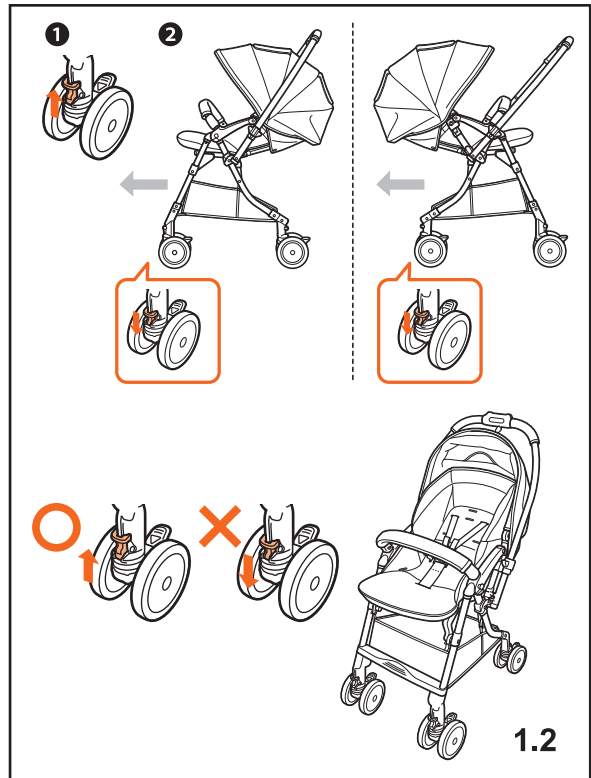
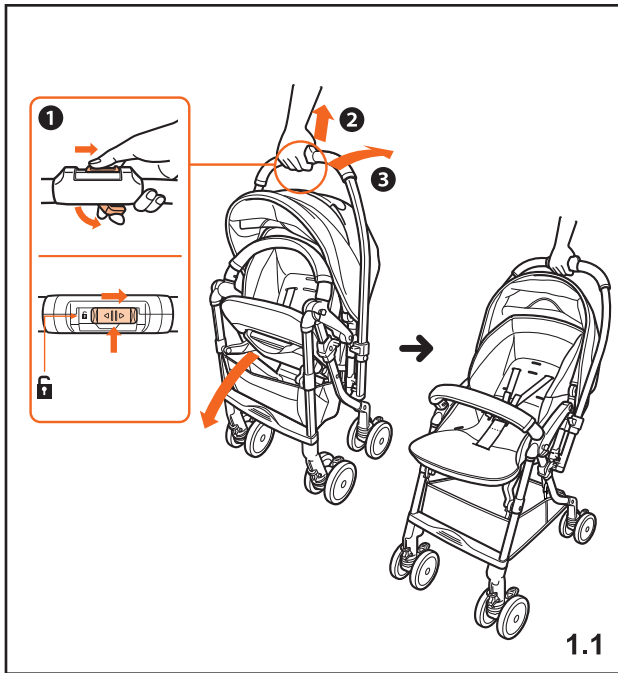

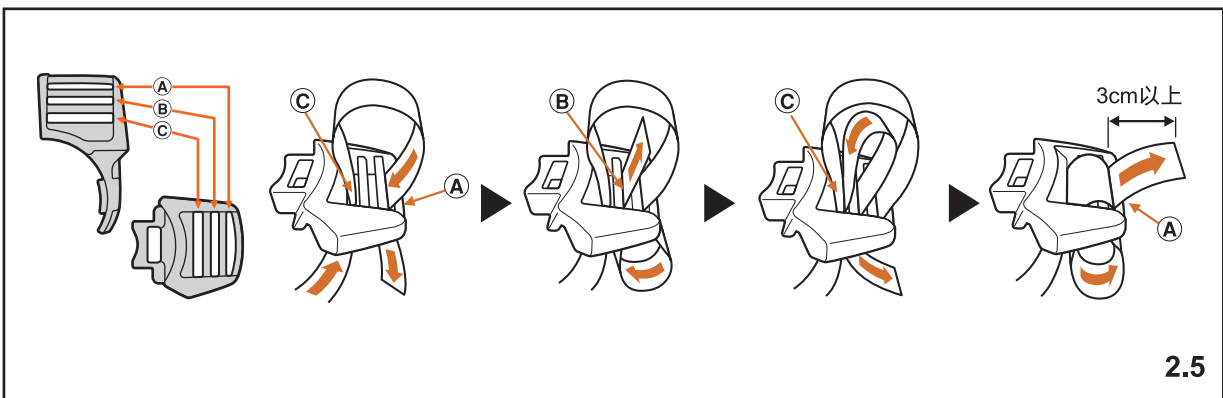
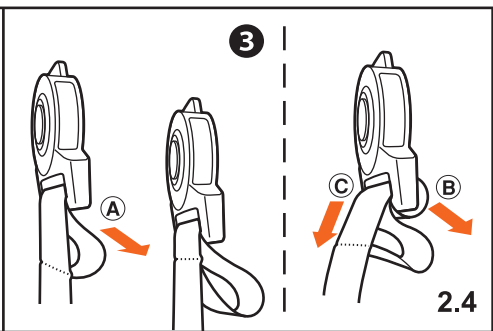
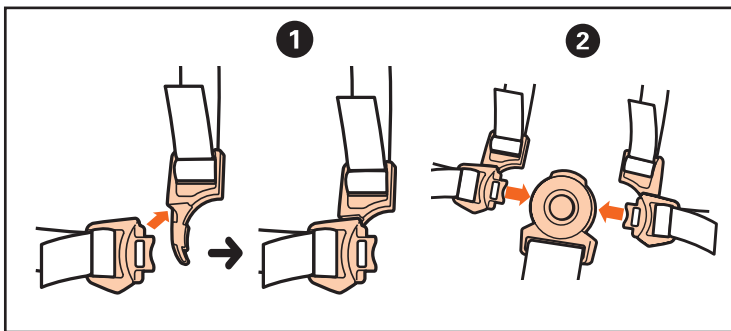
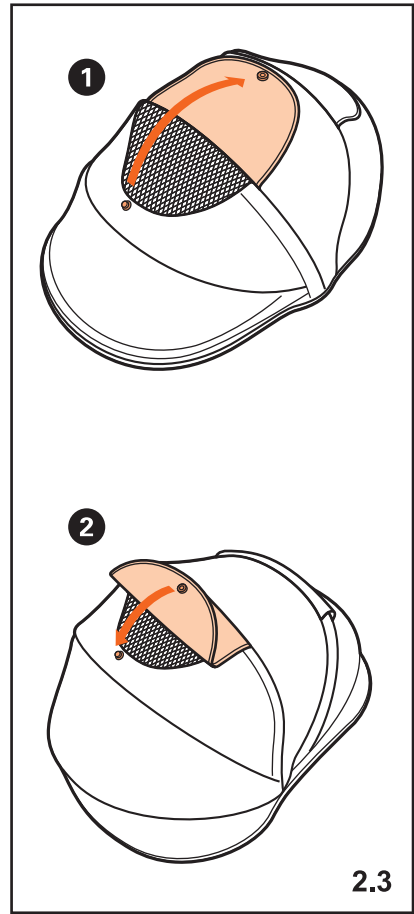
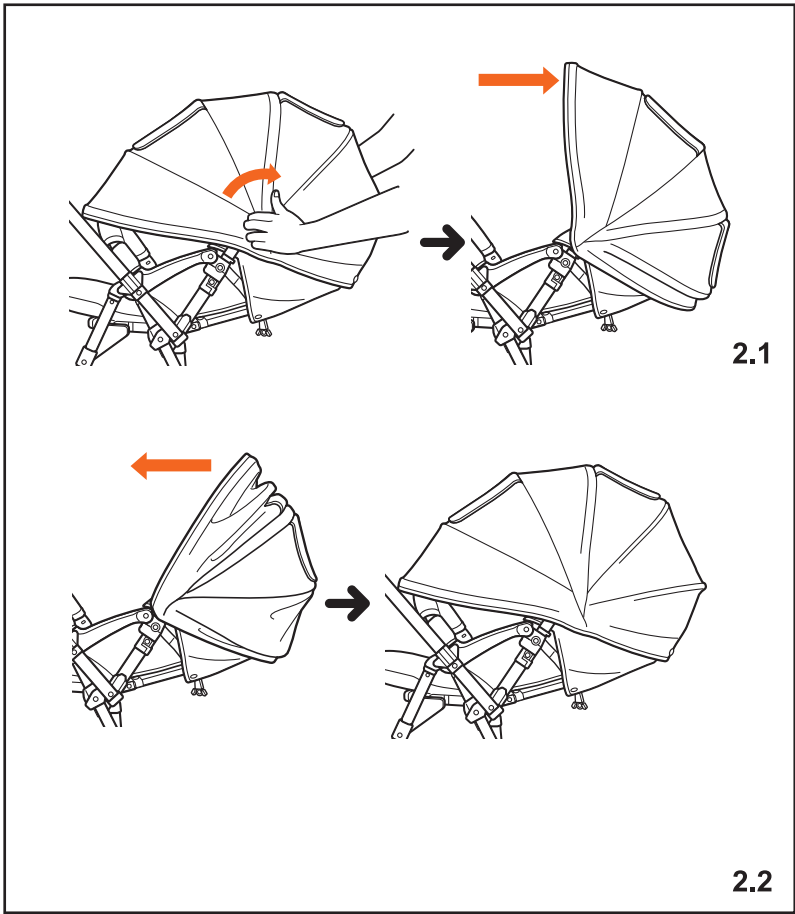

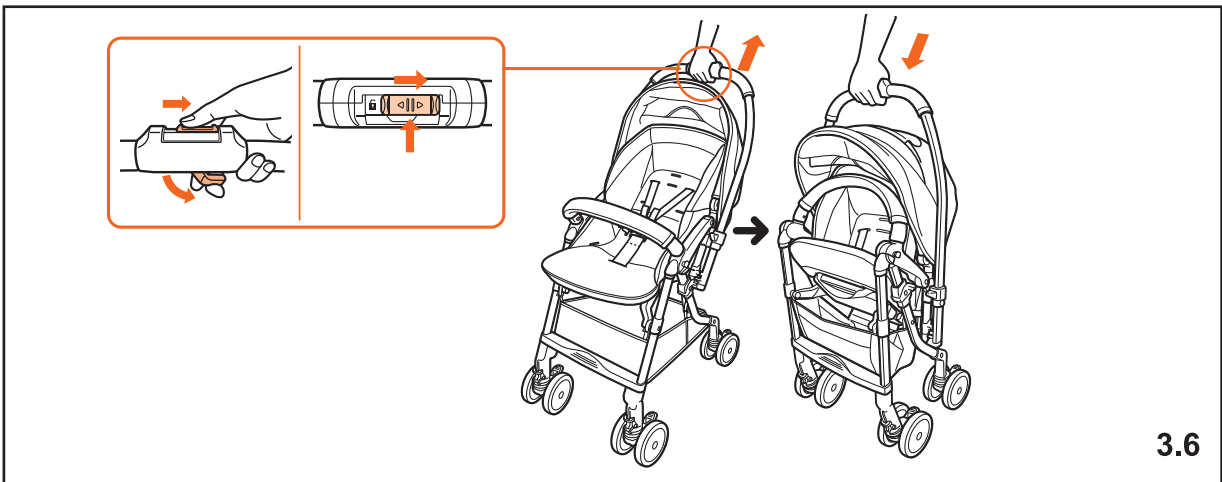
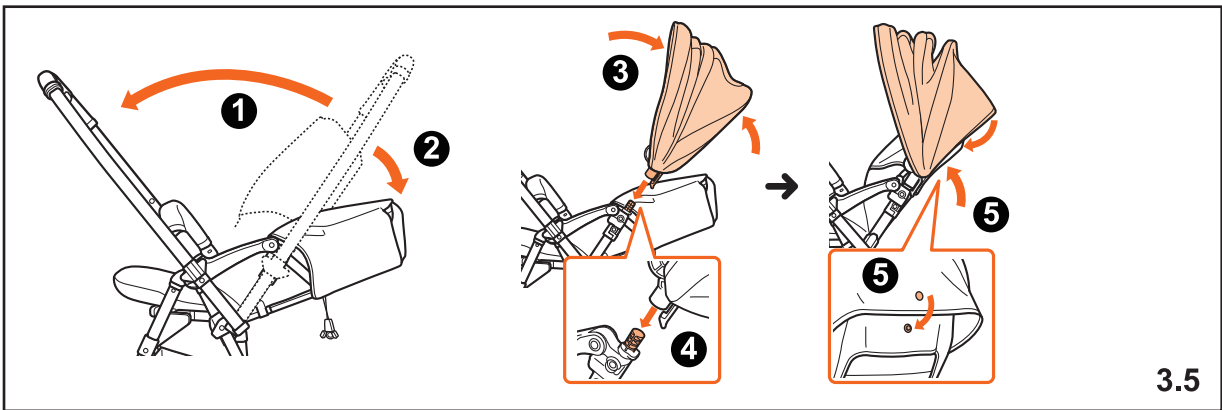
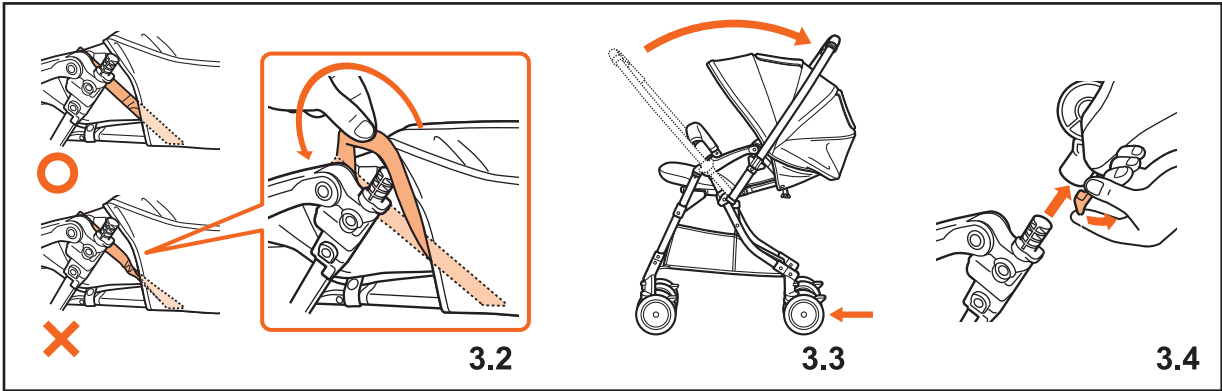
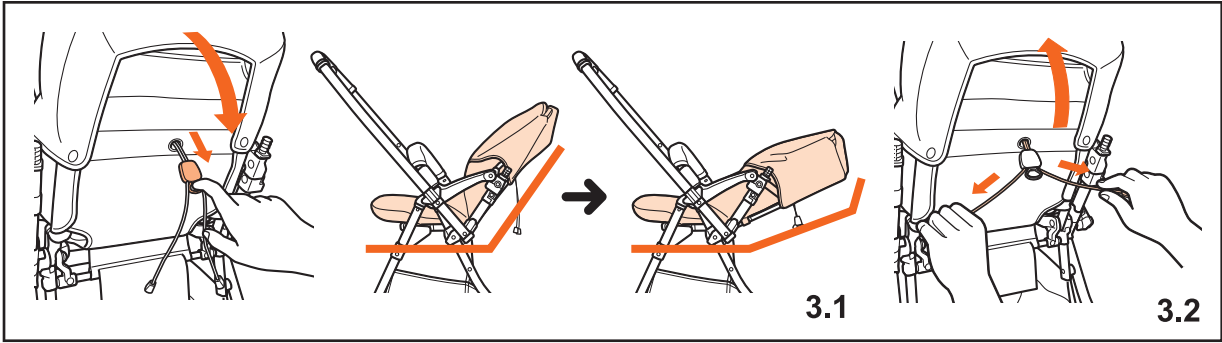

Max : 5kg

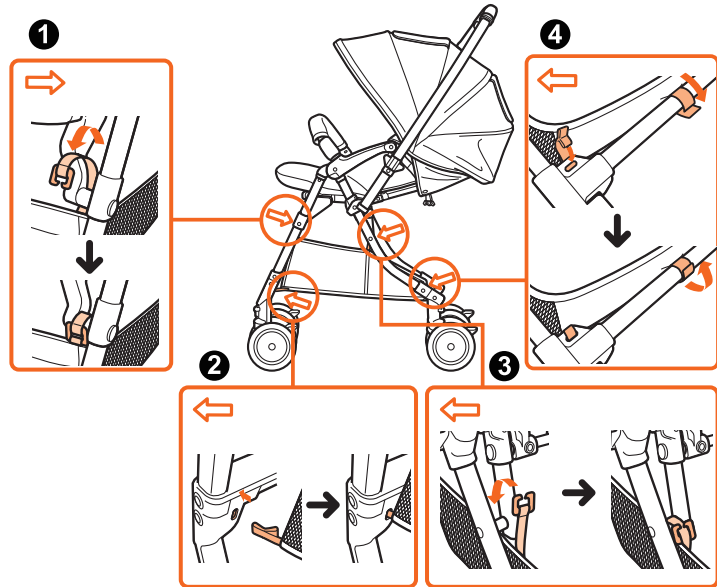
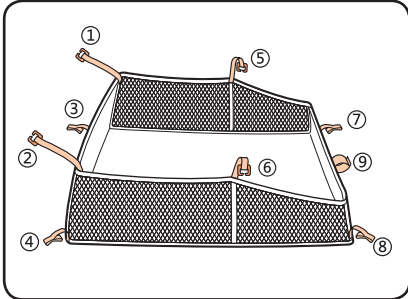

4.1

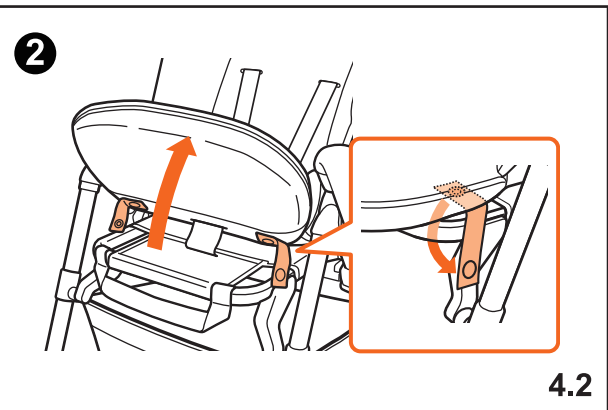
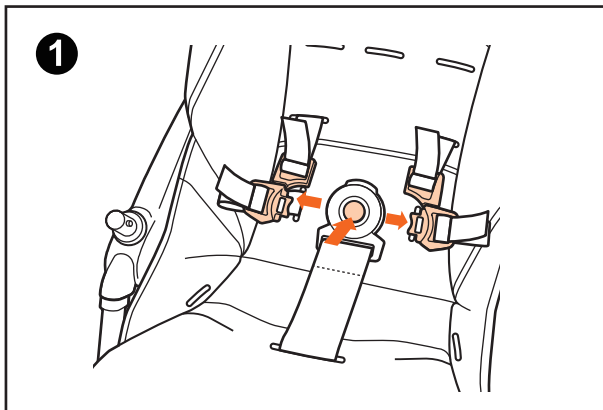

4.2

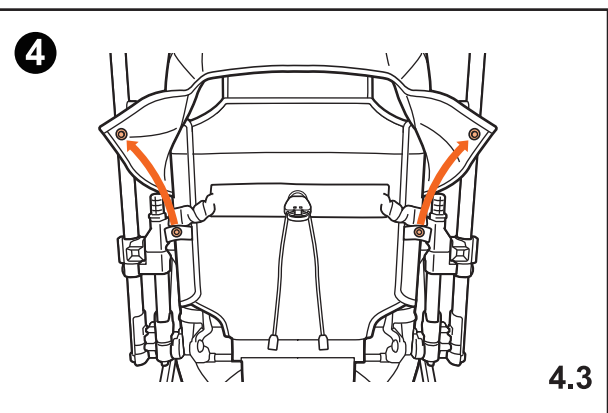
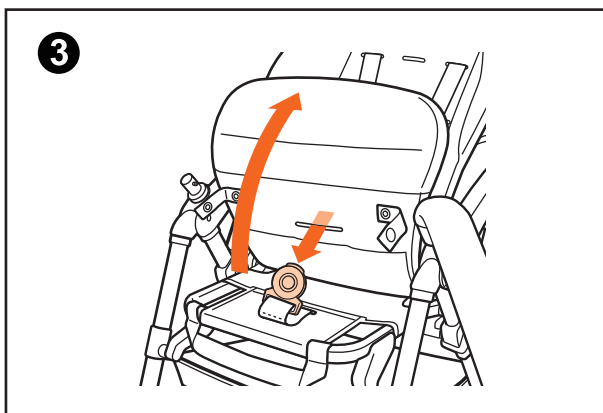

4.3

4

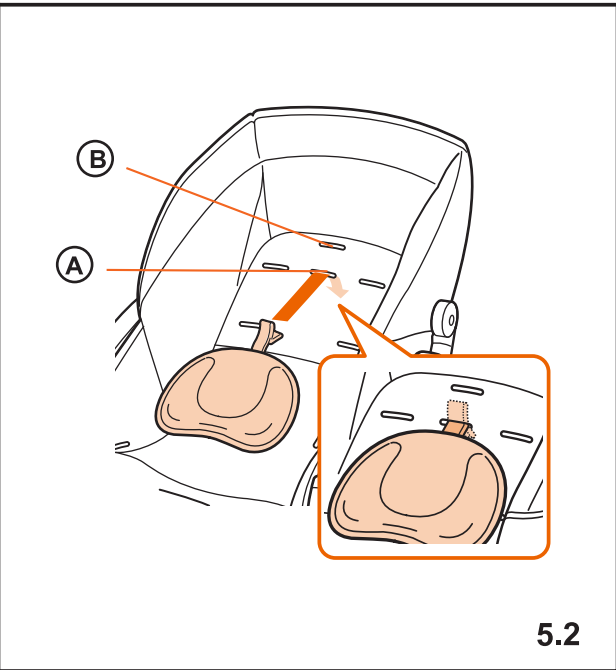
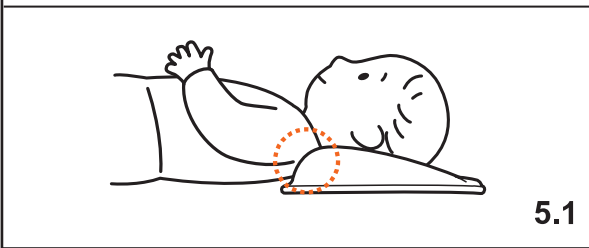
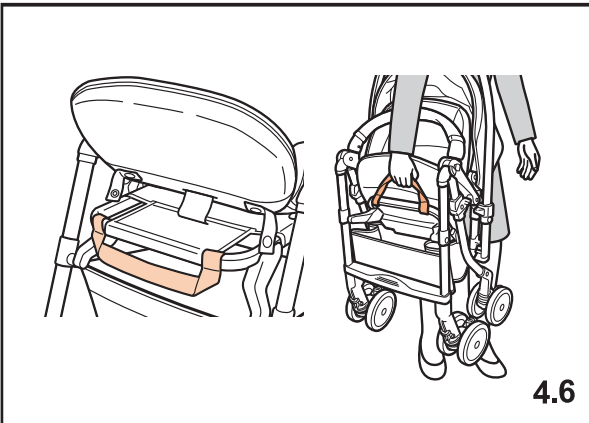
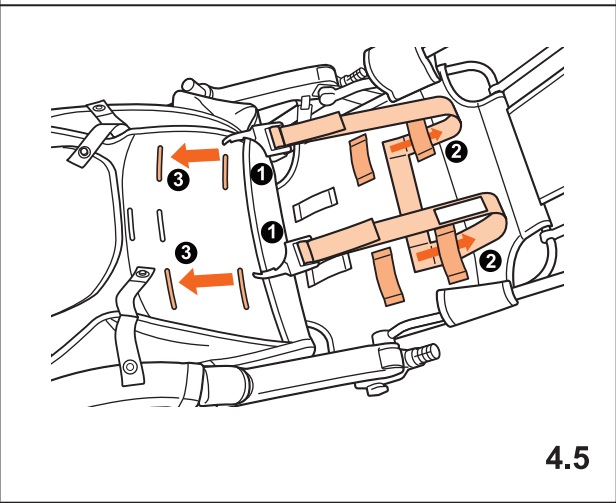
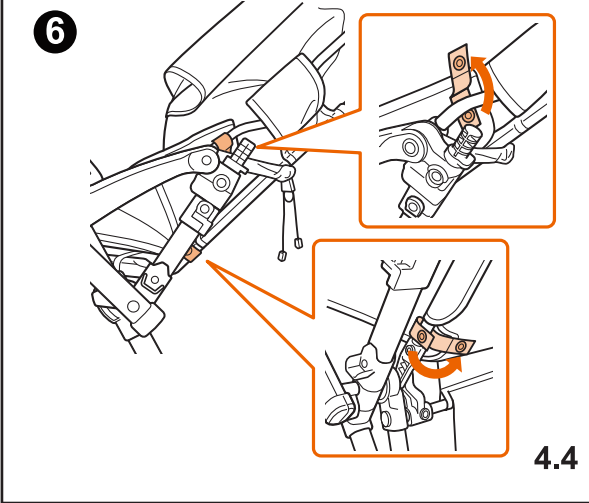
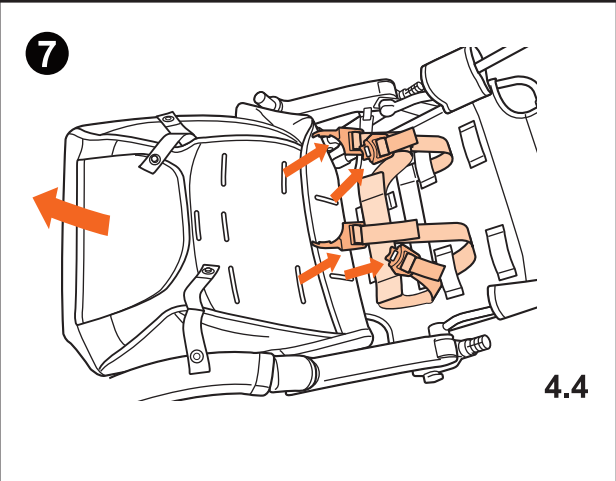
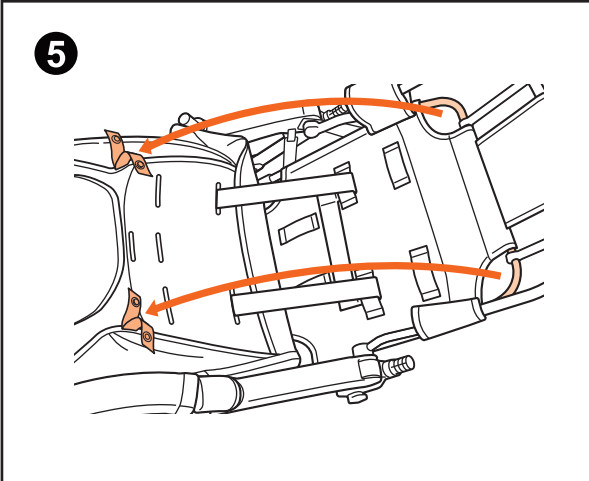

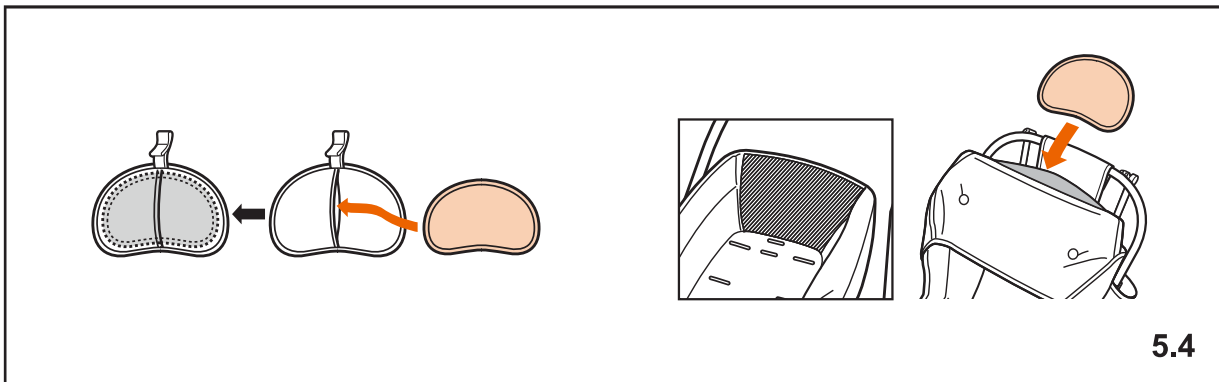
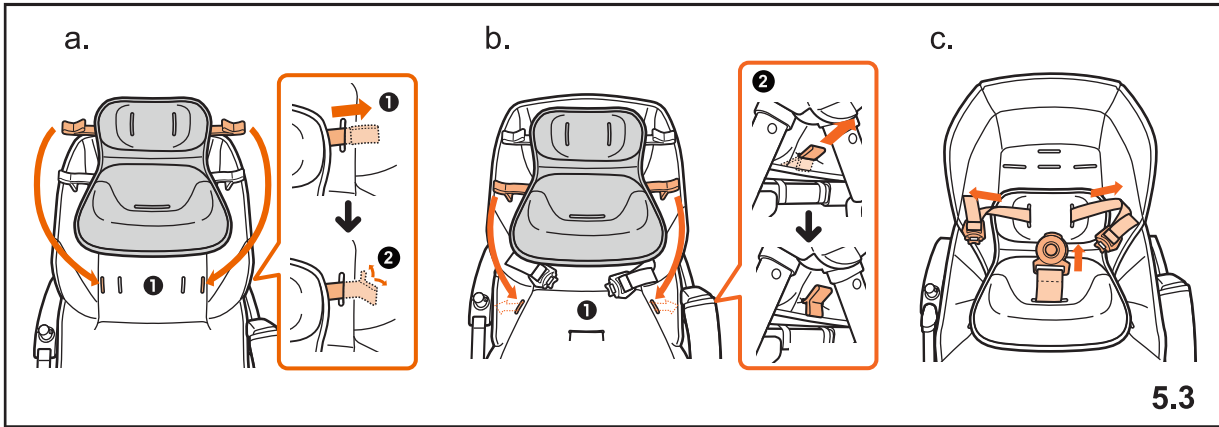

IMPORTANT : KEEP THESE INSTRUCTIONS FOR FUTURE REFERENCE.

⚠ WARNING (Incorrect operation may cause serious injury or death)

Please read this instruction manual carefully and keep it for future reference. The safety of the child may be seriously endangered if the instructions are not followed.

You are personally responsible for the safety of your child.

The stroller is suitable for children from 1 month to 15 kg (approximately 3 years of age).

EN

- Ensure that all the locking devices are engaged before use.
- Always apply the parking brake when you are stationary.
- Do not rely too much on the stoppers even when the stroller is parked empty.
- When a baby is in the stroller, you should always pay attention to the stroller to avoid any danger. In addition, both the left and right parking locks should be used at the same time to avoid accidental sliding or overturning.
- Keep all small parts away from children as they are choking hazard.
- To prevent the risk of suffocation, always keep the plastic bags out of the reach of children.
- Overloading, incorrect folding and the use of non-approved accessories such as buggy boards may damage or break this stroller.
- Always let the child wear the seat belt in the stroller to avoid any possible accident.
- The child being carried by the stroller must be tied with the seat belt that contains the crotch belt, waist belt and shoulder belt. The front guard cannot prevent the child from standing up from the cushion. Make sure the seat belt is not loose to prevent the child from suddenly falling out of the stroller.
- Pay attention to child even when seat belt is in use in case of any sudden movement of child causing it to fall off.
- Do not cross the shoulder belts with each other when securing the shoulder belts to the insert plastic. Otherwise excessive pressure may cause to child's neck.
- Do not use the seat cushion which rift is found. Otherwise the seat cushion may not function as designed or the child may have chance to swallow the material inside the cushion.
- Never leave the child in a stroller without seat cushion. The child's hands or feet may get jammed between the stroller frame.
- When a child is sitting in it, the caretaker is not allowed to leave.
- Make sure the open-fold lock is engaged completely before use. Otherwise the stroller may fold suddenly when using.

IMPORTANT : KEEP THESE INSTRUCTIONS FOR FUTURE REFERENCE.

⚠ WARNING (Incorrect operation may cause serious injury or death)

- To prevent the stroller from accidental slippage, or falling off from the stroller caused by loosening of the front guard, do not hold the front guard or place like that when moving the stroller.
- Do not let the child operate the front guard. It may make the child to fall off from the stroller.
- Never leave your child unattended.
- Do not allow your child to stand in or on the stroller, it may be dangerous.
- Do not lean on or hang loads on the handle. Putting any load on the handle will affect the stability of the trolley.
- Do not hang any object (except original Combi parts) on the hood or handle to prevent the stroller from overturning.
- Never carry more than one child in the stroller. Do not allow a child to ride or sit on areas other than the seat.
- Excessive weight may cause a hazardous unstable condition .
(Maximum weight: 15kg. Basket maximum load: 5kg)
- Do not use the stroller on stairs.
- Do not let children operate the baby stroller to avoid accident.
- Be careful of those around you to avoid pinching their fingers when you are opening or folding the stroller or adjusting the seat angle.
- Keep your child hands away from moving/folding parts when folding or unfolding or adjusting the stroller.
- Do not apply a lifted seat to baby who cannot sit straight by itself, most reclined seat must be used.
- When pushing the stroller, please walk slowly to avoid any damage to the stroller swivel wheels or any tipping over happened.
- Don't let others touch when you open the stroller to avoid accidental injuries.
- In changing the handle direction, check and ensure that the baby's hands and feet are not on the side of armrest to avoid pinching.
- Do not reverse handle while pushing the stroller otherwise the occupant may be in danger.
- Shoulder belt hole positions on the seat and the cushion must be aligned. If upper shoulder belt hole on the seat is used, upper shoulder belt hole on the cushion should be used; otherwise the child may be held tightly because the shoulder belt is not long enough.
- Do not adjust the seat angle while pushing the stroller because this is very dangerous.

IMPORTANT : KEEP THESE INSTRUCTIONS FOR FUTURE REFERENCE.



WARNING (Incorrect operation may cause serious injury or death)

WARNING: It may be dangerous to leave your child unattended.

WARNING: Ensure that all the locking devices are engaged before use.

WARNING: When your baby is sitting in the stroller, please be sure to fasten the safety belt.

WARNING: Do not use in a reclined angle less than 150° for a child under 6 months old.

WARNING: Any loading attached to the handle affects the stability of the stroller.

WARNING: Please always fasten the five-point seat belt to ensure the baby's safety .

WARNING: Check that the pram body or seat unit attachment devices are correctly engaged before use.

WARNING: This product is not suitable for running or skating.

EN

⚠ CAUTION (Incorrect operation may cause injury or component damage)

- Make sure all snaps are secured before use. Otherwise accident or damage to stroller may cause.
- When adjusting the seat angle with a child in the stroller, loose the shoulder belt first, and then adjust the angle with the other hand holding the backrest. Please be careful not to change the seat angle suddenly.
- Adjust the length of seat belt properly after changing of the seat angle.
- Please do not touch the folding lever except when folding the stroller.
- When opening or folding up the stroller and reversing the handle, be careful and avoid the seat cushion, seat belt, blanket and toys, etc., pinched into the stroller body.
- If one gives excessive shock to the front wheels when getting over the step, stroller may fall down and cause damages. (It is the same as changing handle direction to use the stroller.) When stepping over, such as a curb, please slow down even a slight difference level, pull downward the handle and step on the foot-step, and make sure to pass the front wheel to get over the step.
- Never lift the stroller or use it on escalators when your child is sitting or lying in the stroller.
- This stroller requires regular maintenance by the user.
- Before use, check that the product and all its components have not been damaged during transportation.
- Please do not use the stroller in whatever purposes other than seating a baby. Failure to comply may result in damage of the stroller.
- Do not pull or twist or forcibly press down the front guard hardly. Otherwise the stroller may be damaged.
- Do not use an adult sit on the stroller, or add loading on the stroller to avoid any damage to it.
- When used in summer, outdoor weather and road conditions will increase the temperature of the stroller, that using for a long time should be avoided.
- Avoid storing the stroller in places that under high temperature, near a heat source or inside a car. Exposure to high temperature may damage or deform the stroller.
- Check regularly that all screws, bolts and nuts are engaged tightly.
- Swivel wheel lever should be secured at the same side of the pushing person.
- Lever secured in wrong position may affect maneuvering or damage the product.
- For use on trains: This product is not designed to be used on trains. When user attempts to use the product at his /her own risk, please lock stoppers in case of sudden brake or turning. Otherwise stroller may fall off.



CAUTION (Incorrect operation may cause injury or component damage)

EN

- Do not press on the folding lever while lift the stroller to avoid damage to the part.
- Make sure the basket is empty before folding up the stroller.
- Make sure the canopy is completely folded up before folding the stroller to avoid damage of the parts.
- Do not touch at the handle lock when folding or unfolding the stroller. Otherwise damage may cause to the stroller.
- Do not lay down the stroller and do not put things on the canopy to avoid deformation.
- Do not hold of an opened front guard to pull the baby stroller.
- Please do not put the stroller near fire.
- The stroller may slide or overturn accidentally even if the parking lock is engaged.
- Do not leave baby stroller at road side or slope even when it is not in use.
- Do not use the stroller on steep slopes, stairs, escalators, rough roads, beaches, mud, etc.
- When pushing the stroller, be careful of the road depression to prevent the front wheels from being trapped into the slot and overturning.
- In the event of damage or operation problems, stop using the stroller immediately.
- If damage is identified, do not use the product and keep it out of reach of children.
- Never leave the stroller close to stairs or steps.
- Use the stroller on flat ground only. Never use any parts from other sources than the original producer. Do not refit the stroller.
- Do not make any modifications to the product.
- Do not use the most reclined angle if the baby's head touches at the head rest.
- Do not use the stroller in snowy, windy days or wet road to avoid the stroller or guardian from slipping.
- Do not use the stroller in lightning days to avoid thunder stroke.
- Do not modify or remodel the stroller.
- Do not attach other accessory like buggy board on the main body during a child being carried in stroller, otherwise accident or damage to stroller may cause.
- Do not use this stroller inside the bus.



CAUTION (Incorrect operation may cause injury or component damage)

- **Lift front wheels and pay particular attention to gaps or ditch when crossing rail road.**
- **No continuous use for a long period: Continuous use for a long period of time may exhaust baby. No continuous use of more than 2 hours for a baby seated in a reclined seat and 1 hour in an upright seat.**
- **When feel jammed, please do not forcibly fold the stroller to prevent from any damage. You should re-open the stroller to check and operate again.**
- **Turn swivel wheels to inner side and lock up before folding the stroller. Improper position may cause stroller becoming imbalanced after folded.**
- **Do not put things too sharp or too large into the basket.**
- **Please regularly clean and check the stroller. Only use neutral detergent to clean the stroller body.**
- **Make sure no oil or lubricant is left on parts such as front guard or armrest where baby may have chance to lick.**

EN

LIST OF COMPONENTS

- | | | |
|------------------------|---------------------------------|------------------------------------|
| 1. Handle | 14. Seat reclining buckle | 27. Crotch belt |
| 2. Front guard buttons | 15. Reclining cord | 28. Crotch buckle |
| 3. Front guard | 16. Back ventilation window | 29. Shoulder and waist belt buckle |
| 4. Front guard cover | 17. Safety lock | 30. Head support |
| 5. Basket | 18. Folding lever | 31. EggShock pad |
| 6. Foot rest | 19. Top window | 32. Body & Hip support |
| 7. Swivel wheel lock | 20. Top window cover | 33. Handle lock |
| 8. Seat cushion | 21. Ventilation window | 34. Open/Fold lock |
| 9. Headrest | 22. Shoulder belt | 35. Rear leg latches |
| 10. Armrest | 23. Shoulder belt insert outlet | 36. Rear stay |
| 11. Stopper | 24. Head support insert outlet | 37. Carrying grip |
| 12. Canopy snap | 25. Waist belt insert outlet | |
| 13. Seat cushion snap | 26. Waist belt | |

INSTRUCTIONS

Unfolding/Opening (Figure 1.1)

- ❶ Slide the safety lock as demonstrated direction and hold it in place.
- ❷ Grip and pull the folding lever upwards simultaneously.
- ❸ Slightly lift the stroller and open it.

Using the swivel wheels (Figure 1.2)

- ❶ To use the swivel wheels - Lift the swivel wheel locks (left and right) to release. (according to the moving direction).
- ❷ Swivel wheels not in use - Press down the swivel wheel locks (the ones at the same direction of the user) to lock.

WARNING: When you switched the normal use or handle, please make sure to raise the swivel wheel locks to release the locks. If you do not release the locks, there is a possibility that the wheels are not automatically switched. When reversing the handle, please release swivel locks (total 4 places). When the wheels are locked in the wrong direction, the stroller may damage to the parts while open.

Using the stoppers (Figure 1.3)

- ❶ To lock wheels, press the stoppers down which are located at wheels on both left and right sides.
- ❷ Try to push the stroller back and forth slightly to ensure that the stoppers are properly engaged.

WARNING: Always engage the stoppers when you leave the stroller.

Release the stoppers (Figure 1.4)

- ❶ Lift the stoppers to unlock.

Open the front guard (Figure 1.5)

- ❶ Press and hold the button at the end of the front guard as illustrated.
- ❷ Detach the front guard.

Attach the front guard (Figure 1.6)

To attach front guard, lift and plug into the projected part at the end of the armrest.

WARNING: Do not hold the front guard to lift the stroller.

Sun Canopy (Figure 2.1)

Unfold the canopy from backward.

(Figure 2.2)

Full size canopy: Pull canopy forward to adjust the size.

Top window (Figure 2.3)

- ① Open top window by releasing snaps.
- ② Fasten the snap to close top window.

Install and adjust the crotch belt (Figure 2.4)

- ① Attach shoulder belts to the shoulder belt hook of the left and right insert plastics.
- ② Pull out the crotch belt and put the insert plastics into the buckle until a "Click" sound is heard.
- ③ Tightening **A** Pull out the center belt to the end.
Extending **B** Follow the direction of arrow and pull out the belt to end.
C Follow the direction of arrow and pull the belt to the end.

Pull the center belt end Pull the shoulder belts and waist belts to check if it is secured.

WARNING: Avoid serious injury from falling or sliding out. Always use seat belt.

NOTE: When changing the seat recline angle, always check the harness to ensure it is still optimally adjusted.

Adjusting the waist belt (Figure 2.5)

Pull the belt in the direction as illustrated to adjust its length.

NOTE: Always leave at least 3cm at the belt end.

NOTE: To release harness, go in the steps reverse.

The steps of adjusting shoulder and waist belts are the same.

Adjusting the backrest (Figure 3.1)

Support the backrest with one hand before reclining the backrest.

The headrest will be lifted automatically after the backrest is reclined. (movable headguard)

(Figure 3.2)

Pull the reclining cords as illustrated to raise the seat back.

NOTE: Raising the backrest may be difficult while a child is leaning on the backrest.

Reversing handle (Figure 3.3)

Lift and release the handle locks to change the handle direction until the locks are secured in places.

Detaching the sun canopy (Figure 3.4)

Pull out the canopy joint end gradually, pull up the canopy away from the holder.

Attaching the sun canopy (Figure 3.5)

- ① Switch the handle to face rear. Refer to this page "Reversing the handle".
- ② Recline the backrest to the lowest angle. Refer to this page "Adjusting the backrest".
- ③ Place the canopy facing the proper direction.
- ④ Plug the canopy joint into the canopy holder.
- ⑤ Lift up the backrest, and fasten the canopy snaps.

EN

Folding the stroller (Figure 3.6)

- 1 Slide to release the safety lock of direction as illustrated.
- 2 Grip the folding lever and slightly lift up the handle, then press down the handle to fold the stroller.

WARNING: When opening and closing the stroller, please ensure your child and other children are kept at a safe distance. Please ensure that they are not contact with any mounting parts. Remove all items from the basket before folding the stroller.

EN

Basket (Figure 4.1)

The basket can carry a maximum weight of 5kgs. You can attach and remove it using the belts and snaps according to step 1, 2, 3 and 4.

Removing the seat cushion (Figure 4.2 - 4.4)

- 1 Press the crotch buckle release button and release the harness.
- 2 Release the snaps (2 places) in the inner side of the seat cushion.
- 3 Release the crotch belt from the seat cushion.
- 4 Release the snaps underneath (base board) and pull out the installation belt.
- 5 Release the left and right snaps which are secured to the base board. (2 places)
- 6 Release the snaps (4 places in total) at the side tube and the lower tube of the base seat.
- 7 Remove waist belt and shoulder belt and then remove seat cushion from base seat. (2 places)

NOTE: To install seat, go in the steps reverse.

WARNING: Make sure the seat cushion has been correctly attached before use.

Adjust shoulder belt heights (Figure 4.5)

- 1 Pull out shoulder belt from seat cushion and backrest.
- 2 Insert the shoulder belt through the correct slots on the backrest.
- 3 Insert the shoulder belt through the correct slots on the seat cushion, make sure you use the slots in the same height.

NOTE: The lowest shoulder belt insert outlet should be used for children under 6 months.

How to use the carrying grip (Figure 4.6)

Carrying grip is used for carrying the folded stroller.
Fold the stroller, grab the attached carrying grip on the seat frame.
Carry the handle under the armpit.

Installing the dacco cushion (Figure 5.1)

Correct position of head support - The cushion pad of the head support should just touch at the child's neck. Below is the age reference of using dacco cushion.

	1 Month	starting to sit without aid	36 Months	
Head pad	←————→			※1 Put EggShock pad into pocket on seat cushion to use. ※2 Indicated age for reference only, please apply according to child's body size.
EggShock pad	←————→ ←————→ Attached in the head pad Attached in the seat cushion			
Body&Hip support	←————→			

Installing the head support (Figure 5.2)

Loop the head support belt through the head support hole, the belt is tipped opposite through the hole to attach. After it is installed, check if it is well secured to the seat cushion or not by slightly pulling.

Reference for head support insert outlets (A) (B)

(A) for child from around 1 month to 4 months (B) for child from around 4 months to 7 months.

Installing Body & Hip support (Figure 5.3)

- Using the supporting belts (upper position) of the Body & Hip support to pass thru the holes of the seat cushion body support location. To fix the supporting belts by opening the tail at the end.
- Using the supporting belts (upper position) of the Body & Hip support to pass thru the holes of the seat cushion hip support location. To fix the supporting belts by opening the tail at the end.
- The both sides of waist belts pass thru the upper holes of the Body & Hip support. The crotch belt pass thru the lower belt hole of the Body & Hip support.

WARNING: Even the baby is under 3 years old, please stop using the Body & Hip support if it does not fit the baby size. To take out the Body & Hip support, follow the reverse steps of the installation.

To use with EggShock pad (Figure 5.4)

Putting into the head support to use.

The EggShock pad can be inserted into the head support of Dacco Seat to protect child from the vibrations from the ground when strolling.

Insert the EggShock pad from the rear packet of the head support .

Putting into seat cushion to use. Insert the Eggshock pad from the rear packet of the seat cushion.

Hints for maintenance

- Never apply force on any mechanism or moving parts.
- To prevent mildew forming, do not store this product in a wet or humid environment.
- Avoid prolonged exposure of the product to rain or snow.
- Clean the plastic and metal parts with a wet cloth. For stubborn stains, use a diluted mild detergent.
- You may lubricate moving parts if the operation or movement of the stroller is not smooth. Do not apply excessive lubricant as it may stain with dust which may cause malfunction. Please do not apply any lubricating oil on handle lock (open/fold lock), safety belt buckle, front guard plug, safety lock, folding lever and swiveling lock that will cause malfunction.

Cleaning and maintaining fabrics

- ✘ Be careful not to injure the plastics on canopy and the snaps from basket.
- ✘ Due to the characteristic of the product, the color may fade after numbers of washing.
- ✘ It is recommended to wash with neutral detergent which does not contain fluorescent brightener, bleach etc.
- ✘ Always keep clean due to the condition of storage, the mildew may be generated.
- Washing of the Body & Hip support, the shoulder belt, the waist belt .
 - Hand wash in warm water or machine-wash gently .
 - When using the washing machine, put the laundries into the washing net before washing. Otherwise a fray and damage may cause.
 - Detach the seat cushion and wash according to the washing instructions.
 - It is recommended to wash and spin separately with other clothes.
 - Rinse thoroughly, wring out lightly, and then arrange the shape and dry in the shade.
 - Do not use drying machine or dry cleaning.
- Washing of the canopy, crotch belt and the basket.
 - Do not soak into the water. Use sponge or brush wipe off the dirt with warm water.
 - After wipe off the dirt by detergent, use a cloth to wipe off the excess water and detergent.
 - Dry in shade area after wipe off water by dried cloth.

使用前請詳細閱讀本說明書並妥善保存作日後參考之用

警告 (錯誤操作可能引致重大傷害或死亡)

不按照本使用說明書指引使用手推車，可能對幼兒造成重大傷害。

幼兒的安全是您的責任。

本產品適用於一個月初生兒至15kg (大約三歲) 的幼兒。

- 使用手推車前請確保所有的鎖定裝置都已處於鎖定狀態。
- 停止手推車時，請使用停車鎖。
- 不論有否承載嬰兒，停車時勿過分信賴停車裝置的性能。
- 即使已使用停車鎖，如載有嬰兒，應隨時留意手推車附近，以防任何危險發生。此外，停車鎖應左右兩方同時使用，以免意外滑動或翻倒。
- 切勿將小配件放近幼兒，以免幼兒吞下而造成窒息的危險。
- 為了防止幼兒窒息的危險，在拆開包裝後，請將膠袋之類的包裝物料丟棄。
- 過分超載，錯誤摺疊以及使用未經認可的配件會對手推車造成損壞。
- 避免因跌落或滑出而造成嚴重傷害，請確保兒童在任何時刻佩戴安全帶。
- 乘載幼兒時必須繫上安全帶，安全帶包含中央帶，腰帶和肩帶。前護欄不能防止幼兒從座墊上站起來。請確認安全帶沒有鬆脫，以免幼兒突然跌出手推車。
- 為防止幼兒突如其來的動作令其跌出手推車，即使已經扣上安全帶，也請經常留意幼兒，小心使用。
- 肩帶扣在插扣片上時，請勿交叉肩帶，以免肩帶對幼兒頸部造成壓迫。
- 請勿使用已破損的座墊，以免座墊不能發揮其應有功能，或令幼兒誤吞內裏的棉花等。
- 切勿讓嬰幼兒乘坐未安裝座墊的手推車，幼兒的手腳可能被車架夾到。
- 當兒童乘坐時，看護人不要離開。
- 使用前務必確認開關鎖已鎖上，否則手推車會有突然摺起的危險。
- 切勿手執前護欄等地方搬動手推車，以免手推車意外滑脫，或令前護欄鬆脫，引致手推車掉下。
- 不要讓幼兒操作前護欄以免其意外跌倒。
- 切勿讓幼兒單獨坐在車上。
- 不可讓幼兒站立在車上，這是十分危險的。
- 切勿把身體靠於或把重物掛於把手上。在把手上放置任何附載重量都會影響手推車的穩定性。
- 切勿懸掛物件 (康貝原廠的配件除外) 於車篷或把手上，以免引致手推車翻倒。
- 切勿承載超過一名幼兒，或讓幼兒坐在座椅以外的地方。
- 承載超重會容易產生不穩定的危險情況。(最大體重：15kg。置物籃最大承載重量：5kg。)
- 禁止於樓梯間使用手推車。
- 不要讓幼兒操作手推車，以免手推車翻倒或發生其他意外。
- 開關手推車或調節座席時要注意四周旁人及小孩，以免夾傷指頭。

使用前請詳細閱讀本說明書並妥善保存作日後參考之用

警告 (錯誤操作可能引致重大傷害或死亡)

- 開關或調節手推車時，請勿讓幼兒的手接觸活動零件部分。
- 對還未能坐直的幼兒，切勿使用座椅模式，請調節成臥床模式使用（最平躺的角度）。
- 推動手推車時請勿奔跑，應慢慢步行，以免轉向輪損壞，或引致翻倒等意外。
- 打開手推車時不要讓他人接觸，以免意外夾傷。
- 轉換把手方向時，請小心確認幼兒手足沒有放在側扶手上，以免夾傷。
- 請勿一邊推動手推車，一邊轉換把手方向，以免引致危險。
- 在座席使用的肩帶穿孔和座墊的肩帶穿孔位置要一致。如使用座席的上方肩帶穿孔，座墊亦同樣要使用上方肩帶穿孔，不然肩帶有可能因長度不足繫緊幼兒。
- 一邊推行一邊調整座席角度是非常危險的，請勿同時進行。

警告：不應在無人照顧下把嬰兒獨放在嬰兒車內，以免發生危險。

警告：使用嬰兒車前，請確保嬰兒車之所有安全鎖掣已鎖上。

警告：當嬰兒坐在嬰兒車上時，請務必使用安全帶。

警告：當靠背角度少於150度時，不適合6個月以下幼兒使用。

警告：任何物件負重於嬰兒車把手會影響嬰兒車的穩定性。

警告：請必須隨時將五點式安全帶扣上以確保寶寶乘車時的安全。

警告：使用前，請先檢查嬰兒車與所有部件已正確安裝。

警告：此產品不宜同時於跑步或溜冰時使用。

⚠注意 (錯誤操作可能引致受傷或元件損壞)

- 安裝座墊時，請確保所有鈕扣等已經裝好，以免引致意外或造成損壞。
- 在已承載幼兒的狀態下調整座席角度時，請先將肩帶調鬆，然後以另外一隻手支持著靠背調節，請注意勿讓座席角度突然改變。
- 調整座席角度後，請重新調整安全帶至適當長度。
- 除開摺手推車外，請勿觸碰開關掣。
- 當操作開關時，請注意及避免可裝拆的座墊、手推車的安全帶、被子，及玩具夾在手推車車體上。
- 當越過不同段差時，若強行附加力量於前車輪上使之與段差碰撞，可能引起手推車損壞和故障，（轉換把手方向使用手推車也是同樣如此）。當越過段差時，即使是微小段差區的地方應減緩推行，並踏上腳踏及往後按下把手往前行，確保前車輪越過段差才可通行。
- 當幼兒乘坐時，請勿在電梯上使用或搬動手推車。
- 使用者必須對本產品作定期保養。
- 每次使用前請檢查配件是否在運輸過程中被損壞。
- 請勿將手推車作承載幼兒以外的用途，否則會引致損壞。
- 請勿用力拉動、扭動、壓下前護欄，以免引致損壞。
- 請勿讓成年人坐上手推車，或在上面放置重物，以免損壞手推車。
- 夏天使用時，戶外的天氣和路面情況會令手推車溫度提高，應避免連續長時間使用。
- 避免將手推車存放於高溫，接近熱源的地方或車廂內，因高溫可使手推車損壞或變形。
- 請定期檢查所有螺絲是否上緊。
- 轉向輪鎖杆應該鎖定於推行者的一方。
- 固定在不正確位置的方向輪鎖杆會令推行更困難，或可能引起手推車故障。
- 有關火車上的使用：本產品並非以火車上的使用為目的所設計的產品。假如閣下自行決定於火車上使用，請小心注意，並使用停車裝置，以免轉彎或剎車時令手推車翻倒。
- 請勿在提起手推車的狀態下按下開關掣，以免引致組件損壞。
- 按開關掣前請先解除安全鎖。錯誤操作可能損壞零件。
- 收起手推車前請先確認置物籃內的物品已取出。
- 收摺前請先確認車篷已經完全收起，以免引致組件損壞。
- 開關手推車時，切勿操作把手鎖，以免造成手推車損壞。
- 收起手推車時，請避免橫放，或於上面置放重物，以免車篷變形。
- 請勿手執開放的護欄來拖動手推車。
- 請勿把手推車放近火源。
- 即使已經鎖上停車鎖，手推車也有可能意外滑動或翻倒。
- 即使幼兒不在車上，也不可將手推車隨意放在路旁或斜坡等危險地方。

注意 (錯誤操作可能引致受傷或元件損壞)

- 不可於斜坡、階梯、自動扶梯、顛簸坡道、沙灘、泥地等場所使用手推車。
- 推車時請小心路上凹陷之地方，以免前輪意外陷進溝內令手推車翻倒。
- 如手推車出現損壞，應立即停止使用。
- 如發現損壞，請勿使用本產品並將其存放在遠離幼童的地方。
- 請勿將本產品放近樓梯或階梯上。
- 只可在平坦路上使用。請勿使用非原廠供應的零件替換或自行改裝手推車。
- 如發現手推車損壞，請立即停止使用。
- 假如幼兒頭部碰到護頭板時，請勿使用躺臥角度。
- 請勿於雪地和強風時或濕滑路面上使用，以免令手推車或監護者意外翻倒。
- 請勿於打雷時使用手推車，以免意外遭受雷擊。
- 請勿隨意改造或拆卸手推車。
- 請勿外加任何以輪板或元件於主體上承載幼兒，以免對手推車造成損壞。
- 請勿於巴士上使用手推車。
- 跨越火車軌和汽車道的十字道口等時，請提高前輪跨越間隙，以免前輪意外卡在溝內。
- 禁止連續長時間使用：連續長時間使用會對幼兒造成負擔。躺臥姿勢的連續使用時間上限為2小時，坐著姿勢的則為1小時。
- 感覺有異物卡住時，請勿強行摺疊，以免造成損壞。應先打開手推車，確認後再操作。
- 收摺前請將轉向輪翻往內側然後鎖定。如果不將轉向輪鎖定在內側位置，收摺後手推車將較易翻倒。
- 請勿承載太尖或太大的東西。
- 請定期清潔以及檢查手推車。請僅使用中性的清潔劑清潔車架。
- 請注意勿讓油分附在幼兒有機會舔到的地方，如前護欄，扶手等。

部件名稱

- | | | |
|----------|-----------|----------------|
| 1. 把手 | 14. 角度調節扣 | 27. 中央帶 |
| 2. 護欄鬆脫掣 | 15. 角度調節帶 | 28. 中央帶扣 |
| 3. 前護欄 | 16. 背面透氣窗 | 29. 肩腰帶扣 |
| 4. 護欄套 | 17. 安全鎖 | 30. 護頭墊 |
| 5. 置物籃 | 18. 開關掣 | 31. EggShock 墊 |
| 6. 腳踏 | 19. 幌天窗 | 32. 護背連臀墊 |
| 7. 轉向輪鎖 | 20. 天窗蓋 | 33. 把手鎖 |
| 8. 座墊 | 21. 透氣窗 | 34. 開關鎖 |
| 9. 護頭板 | 22. 肩帶 | 35. 後腳管活動鎖 |
| 10. 扶手 | 23. 肩帶穿孔 | 36. 後腳支桿 |
| 11. 停車鎖 | 24. 護頭墊穿孔 | 37. 輕便捷帶 |
| 12. 幌鈕扣 | 25. 腰帶孔 | |
| 13. 座墊鈕扣 | 26. 腰帶 | |

使用方法

打開手推車 (圖1.1)

- ① 將把手上的安全鎖向箭頭方向滑動並握住。
- ② 同時握著並提起開關掣。
- ③ 稍稍提起並打開手推車。

使用轉向輪 (圖1.2)

- ① 使用轉向功能時，向上推起轉向輪鎖 (左右) 以解除。
- ② 不使用轉向功能時，請按下和推行者同一方向的2處轉向輪鎖以鎖定。

警告： 轉換把手時，必須解除轉向輪鎖。車輪被錯誤的方向鎖住時，打開手推車可能損壞零件。當您已切換至正常使用或正常把手，請務必將腳輪鎖提起解除腳輪。若不解除鎖定，這可能使腳輪不能自動換轉。

使用停車鎖 (圖1.3)

- ① 壓下左右車輪的停車鎖。
- ② 輕輕前後推動推車，確認停車鎖已鎖定。

警告： 在遠離手推車時，請時刻謹記使用停車鎖。

解開停車鎖 (圖1.4)

將停車鎖往上撥即可解鎖。

打開前護欄 (圖1.5)

- ① 如箭頭方向按下前護欄鬆脫掣。
- ② 抽起前護欄。

安裝前連欄 (圖1.6)

要鎖上護欄時，請先將護欄提起，照準末端突起部位，然後插入安裝。

警告： 請勿手執前護欄搬動手推車。

使用車篷

(圖2.1)

以較小幅度使用時，將大型車篷往後收摺。

(圖2.2)

以較大幅度使用時，將大型車篷再往前方翻開。

使用天窗 (圖2.3)

- ① 打開天窗須將鈕扣打開。
- ② 關閉天窗將車篷上的鈕扣重新扣上。

調節中央帶時 (圖2.4)

- ① 將肩帶扣在左右兩方插扣片上的肩帶鉤上。
- ② 拉出中央帶，將左右兩方的插扣片插進中央安全帶扣內，直到聽到[咔嚓]一聲為止。
- ③ 收緊中央帶時，如圖(A)拉出中央帶內側的安全帶到最末端，為最短狀態。
延長時，如圖(B)箭頭方向拉出中央帶末端安全帶後按照圖(C)箭頭方向拉到底，為最長狀態。

警告： 避免因跌落或滑出而造成嚴重傷害，請確保兒童在任何時刻佩戴安全帶。

小提示：當改變靠背角度時，請謹記檢查並確認安全帶已做出最適當的調整。

安裝腰帶 (圖2.5)

將腰帶參照圖示的步驟來進行安裝。

小提示：注意腰帶末端應留下3cm以上的長度。

小提示：若解除請按照相反的步驟操作。

肩帶的調節方法和腰帶的調節方法相同。

調節靠背

- (圖3.1) ① 調低座席角度時，先以單手支撐著靠背，將角度調節扣往下拉調低靠背。
② 擋頸部自動升起。

- (圖3.2) 將角度調節帶往箭頭方向拉來調高靠背角度。

小提示：幼兒靠在靠背時，角度調節會變得困難。

手推車換向 (圖3.3)

將左右兩邊的把手鎖拉起解除後轉換把手方向。直至把手鎖重新鎖上為止。

拆除車篷 (圖3.4)

將插座下方從末端方向拉著插桿末端。慢慢將車篷拔出。

安裝車篷 (圖3.5)

- ① 將把手置於對面位置，詳見本頁「手推車換向」。
- ② 將靠背調至最低位置，詳見本頁「調節靠背」的內容。
- ③ 確認車篷前後方向。
- ④ 然後將車篷插桿插進車身上插座之中。
- ⑤ 背板提起固定兩個幌鈕扣。

收摺手推車 (圖3.6)

如圖中箭頭方向拉動安全鎖作解除。

一邊握住開關掣，一邊提起把手，然後按下把手，推車被摺疊起來。

警告： 在收摺手推車前，請確保與幼兒保持安全的距離，請勿讓幼兒觸及活動零件。

置物籃 (圖4.1)

- ① 置物籃的最大載重量是5kg。
- ② 使用安裝帶子及帶扣並按照步驟 ① ② ③ ④ 安裝或拆除置物籃。

拆除座墊(圖4.2-4.4)

- ① 按下安全帶扣解除安全帶。
- ② 從座墊前端的固定扣帶(2處)上解開固定扣。
- ③ 從座墊上穿出中央帶。
- ④ 解除座板裏側的扣子，再拉出安裝帶子。
- ⑤ 解除座墊扣在背板兩側的扣子(共2處)
- ⑥ 解除側面管和小座席下部管的扣子
- ⑦ 將肩帶、腰帶抽出，然後將座墊從底座取出。

小提示：若安裝請按照相反的步驟來操作。

警告：使用手推車前務必確認座墊已正確安裝。

調節肩帶高度(圖4.5)

- ① 先將肩帶從座墊及靠背上解除。
- ② 將肩帶穿過靠背上正確的肩帶孔。
- ③ 將肩帶穿過座墊上正確對應位置的穿孔，並確認兩邊穿孔在適當的高度。

小提示：當幼兒未滿六個月時，請使用最低的肩帶穿孔。

如何使用輕便捷帶(圖4.6)

- ① 輕便捷帶是用於攜帶摺疊的嬰兒車。
- ② 從摺疊嬰兒車的把手，握著附設在座架上的手提帶子。
- ③ 將把手夾在腋下攜帶使用。

懷抱型座墊的安裝方法(圖5.1)

- ① 護頭墊的安裝位置。護頭墊部分，應該剛剛抵幼兒頸部。
- ② 懷抱型座墊的參考安裝時期。

	1個月	獨自乘坐前期(7個月)	36個月
護頭墊	←————→		
EggShock 墊	←————→ 放在護頭墊中使用		←————→ 放在座墊中使用
護背連臀墊	←————→		

※1 將EggShock 墊放入座墊上的口袋使用。

※2 歲數只作參考，請依照幼兒體格判斷後使用。

護頭墊的安裝方法(圖5.2)

透過護頭墊穿孔通過頭部支援帶，將支援帶摺回繞過穿孔安裝。它被安裝後，輕輕的拉動檢查其是否固定在可移動的座椅。

有關護頭墊穿孔(a)(b)的參考

- A 大約供1個月至4個月的幼兒使用。
- B 大約供4個月至7個月的幼兒使用。

護背連臀墊的安裝方法(圖5.3)

- a. 將護背連臀墊護背上的支援帶穿過座椅上的身體支援帶穿孔。
將支援帶摺回繞過穿孔安裝。
- b. 將護背連臀墊護臀上的支援帶穿過座椅上的臀部支援帶穿孔。
將支援帶摺回繞過穿孔安裝。
- c. 請用護背連臀墊護背上的穿孔穿上腰帶；用護臀上的穿孔穿上中央帶。

警告：即使幼兒是3歲以下若護背連臀墊不適合幼兒體格，請立即停止使用。
拆除時，以相反的安裝步驟拆除。

使用 EggShock 墊(圖5.4)

放進護頭墊內使用時，EggShock 墊可以安裝到 Dacca 墊的頭墊內，在頭墊背部的口袋進行安裝，用於保護幼兒頭部免受推行時的震動影響。

放進座墊內使用時，將座墊頭靠背面的專用口袋打開放入 EggShock 墊。

保養方法

- 切勿強行拉動活動零件或裝置。
- 請勿將產品存放在潮濕的地方以免產品發霉。
- 避免將產品長時間暴露于雨水或雪霜之中。
- 請以濕布清潔金屬及塑膠部分。如遇頑固污垢，可使用稀釋的清潔劑。
- 若感到手推車操作或運行不順暢時，可以添加適量的潤滑劑。注意不要添加過多的潤滑劑，否則反而會容易沾上灰塵，引起操作異常。
注意某些部位不可以加潤滑劑，如把手操作部、座席安全帶扣、前扶手的安裝部、開閉鎖周圍、轉向輪回轉部，否則可能引起動作不良。

清洗縫製品洗滌指引

- ※ 請注意不要損壞車篷的塑膠部分或籃子的U字鉤子等。
- ※ 根據產品的特性，會有輕微的褪色。
- ※ 洗滌的時候建議使用中性洗滌劑。使用含螢光劑、漂白劑的清洗可能會引起皮膚乾燥、濕疹等，所以請不要使用這類洗滌劑。
- ※ 請小心洗滌及保持清潔，同時需確保縫製品保管於通風環境，避免發霉狀況。

● 座墊、肩帶、腰帶等縫製類的洗滌方法

- 請以溫水手洗或弱速機洗。
- 使用洗衣機的時候，請將縫製品放入柔洗袋內，避免縫製品損壞。
- 手洗後，請輕輕的擰乾，大力擰乾的話可能會使縫製品留下褶皺。
- 部分縫製品可能會出現掉色，請跟其他物品分開清洗，另外請避免浸泡。
- 輕輕擰乾後，整理好形狀，放於陰涼處晾乾。
- 請勿使用烘乾機、熨斗及乾洗以免縫製品損壞。

● 車篷、置物籃、保養方法

- 請不要把車篷、置物籃、中央帶類縫製品泡在液體中。請用擰乾的濕布，或是用海綿沾已稀釋的中性清潔劑清潔。
- 使用中性清潔劑把污垢擦拭掉後，為了不讓清洗劑殘留在產品上，請用濕布或海綿反復擦拭。
- 然後用幹布將產品上的水分擦乾後，置於陰涼處陰乾。

產品名稱及型號：手推嬰幼兒車

SUGOCAL Light

製造年份：請參考車體把手貼紙

進口商：台灣康貝股份有限公司

地址：台北市11493內湖路一段360巷6號6樓

電話：(02)7720-8585

統一編號：12946262

製造廠商：Combi Holdings Limited

地址：Room 1003, HK Pacific Centre, 28 Hankow Road, Tsimshatsui, Kowloon, Hong Kong.

原始製造國：中國

置物籃最大承載重量：5 kg以下

適用年齡：一至三十六個月 最大體重：15 kg以下

主要成份或材質：鋁合金、聚酯纖維、聚丙烯

使用方法：請依說明書組合使用

注意事項：乘坐時務必繫好安全帶

緊急處理方法：盡速送醫急救

memo

A series of horizontal dashed lines for writing the memo content.

Combi Corporation

174286030