

Combi

CFS

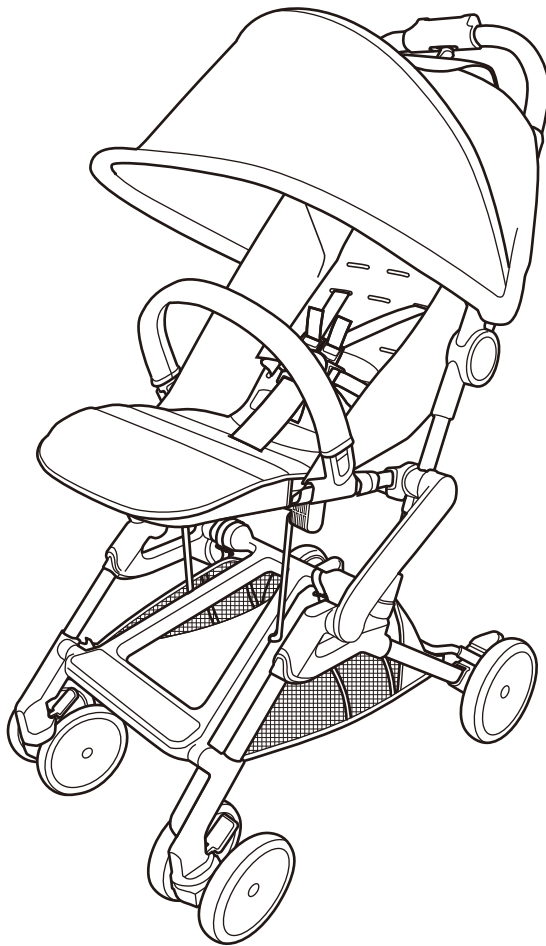

EN

Instruction manual

繁體中文 說明書

IMPORTANT : KEEP THESE INSTRUCTIONS FOR FUTURE REFERENCE.

WARNING (Incorrect operation may cause serious injury or death)

Please read this instruction manual carefully and keep it for future reference. The safety of the child may be seriously endangered if the instructions are not followed. You are personally responsible for the safety of your child.

- The stroller is suitable for children from newborn 1 month to 15kg (approximately 3 years old) under EN 1888 safety standard and CNS 12940.
- Always apply the parking brake when you are stationary.
- Do not rely too much on the stopper even when the stroller is parked empty.
- Even with all stopper engaged, always stay close to the stroller when it is carrying a child.
- Keep all small parts away from children as they are choking hazard.
- To prevent the risk of suffocation, always keep the plastic bags out of the reach of children.
- Overloading, incorrect folding and the use of non-approved accessories such as buggy boards may damage or break this stroller.
- Make sure to use the seat belt (crotch belt, waist belt and shoulder belt) when the child is seated. The front guard is not designed to prevent the child from standing up. Check if the seat belt fits properly, otherwise the baby may fall off from the stroller.
- Pay attention to child even when seat belt is in use in case of any sudden movement of child causing it to fall off.
- Do not cross the shoulder belts with each other when securing the shoulder belts to the insert plastic. Otherwise excessive pressure may be caused to child's neck.
- Do not use the seat cushion on which rift is found. Otherwise the seat cushion may not function as designed or the child may have chance to swallow the material inside the cushion.
- Never leave the child in a stroller without seat cushion. The child's hands or feet maybe get jammed in between the stroller frame.
- Do not leave the stroller when the child is seated.
- Make sure the open-fold lock is engaged completely before use. Otherwise the stroller may fold suddenly in use.
- Do not let the child operate the front guard. It may make the child to fall off from the stroller.
- Do not allow your child to stand in or on the stroller, it may be dangerous.
- Do not lean on or hang loads on the handle.
- Do not hang parcels or accessory items (except Combi original accessories) on the stroller, otherwise tipping over may happen to stroller.
- Never carry more than one child in the stroller. Do not allow a child to ride or sit on any area other than the seat.
- Excessive weight may cause a hazardous unstable condition exist. (Maximum load:15kg. Basket maximum load:5kg)
- Do not use the stroller on stairs.
- Do not let children operate the baby stroller to avoid accident.
- Be careful of those around you to avoid pinching their fingers when you are opening or folding the stroller or adjusting the seat angle.

IMPORTANT : KEEP THESE INSTRUCTIONS FOR FUTURE REFERENCE.

WARNING (Incorrect operation may cause serious injury or death)

- Keep your child's fingers/hands away from moving/folding parts when folding or unfolding or adjusting the stroller.
- Do not apply a lifted seat to baby who cannot sit straight by itself, most reclined seat must be used.
- When pushing the stroller, please walk slowly to avoid any damage to the stroller swivel wheels or any tipping over.
- Open the baby stroller in clear area to avoid pinching baby's finger.
- The used insert outlet from base seat and the cushion should be matched. (e.g. upper insert outlet of base seat should match with upper insert outlet of cushion) . Otherwise, the shoulder belt may not be long enough to harness the baby.
- It is extremely dangerous to adjust the seat angle when pushing the stroller. Do stop the stroller first before operation.
- Mind the road when move the stroller and prevent any wheel get stuck in the gap of the drainage ditch cover(s).

- **It may be dangerous to leave your child unattended.**
- **Ensure that all the locking devices are engaged before use. Such as adjust your seat belt length, fasten your seat belt correctly and the stroller is fully opened.**
- **Always use the restraint system to avoid any possible accident.**
- **Do not use in a reclined angle less than 150° for a child under 6 months old.**
- **Any loading attached to the handle affects the stability of the stroller.**
- **Please always fasten the five-point seat belt to ensure the baby's safety.**
- **Check that the stroller body or seat unit attachment devices are correctly engaged before use.**
- **This product is not suitable for running or skating.**
- **Do not let your child play with this product.**
- **To avoid injury ensure that your child is kept away when unfolding and folding this product.**
- **Do not place the stroller near fire, high temperature, pool, or electric source.**

⚠ CAUTION (Incorrect operation may cause injury or component damage)

- Make sure all snaps are secured before use. Otherwise accident or damage to stroller may happen.
- Loose the shoulder belts and support the backrest with the other hand before lowering the seat angle with a child seated. Do not suddenly change the seat angle while a child is seated.
- Adjust the length of seat belt properly after change of the backrest angle.
- Please do not touch the folding lever except when folding the stroller.
- When opening or folding up the stroller, be careful and avoid the seat cushion, seat belt, blanket and toys, etc., being pinched into the stroller body.
- If one gives excessive shock to the front wheels when getting over the step, stroller may fall down and cause damages. When stepping over, such as a curb, please slow down even a slight difference level, pull downward the handle and step on the foot-step, and make sure to pass the front wheels to get over the step. When going over any step, be cautious of the bumping of the self-supporting rod against the step.
- Never lift the stroller or use it on escalators or stairs when your child is sitting or lying in the stroller.
- This stroller requires regular maintenance by the user.
- Before use, check that the product and all its components have not been damaged during transportation.
- Please do not use the stroller in whatever purposes other than seating a baby. Failure to comply may result in damage of the stroller.
- Do not pull or twist or forcibly press down the front guard hardily. Otherwise the stroller may be damaged.
- Lift the backrest a little to use if the seat is found too narrow when fully reclined. However, the baby should be able to sit straight when stroller is used in such way.
- Do not let an adult sit on the stroller, or add loading on the stroller to avoid any damage to it.
- Avoid continuous outdoor usage particularly during day time in summer.
- Avoid storing the stroller in save places under high temperature, near a heat source or inside a car. Exposure to high temperature may damage or deform the stroller.
- Check regularly that all screws, bolts and nuts are engaged tightly.
- Never secured in wrong position may affect maneuvering or damage the product.
- For use on trains:
This product is not designed to be used on trains. When user attempts to use the product at his /her own risk, please lock stopper in case of sudden brake or turning. Otherwise stroller may fall off.
- Do not press on the folding lever while lift the stroller to avoid damage to the part.
- Make sure to release the safety lock before opening the stroller, misuse may damage parts.
- Make sure the basket is empty before folding up the stroller.
- Make sure the canopy is completely folded up before folding the stroller to avoid damage of the parts.

⚠ CAUTION (Incorrect operation may cause injury or component damage)

- Do not lay down the stroller and do not put things on the canopy to avoid deformation.
- Do not get hold of an opened front guard to pull the baby stroller.
- Even have stopper, this stroller may also be accidental slip or overturned.
- Do not leave baby stroller at road side or slope even when it is not in use.
- Do not use the stroller on steep slopes, stairs, escalators, rough roads, beaches, mud, etc.
- When pushing the stroller, please pay attention to any hole or track on the ground to avoid the front wheel from accidentally getting jammed and tipping over.
- In the event of damage or operation problems, stop using the stroller immediately and keep it out of reach of children.
- Never leave the stroller close to stairs or steps.
- Only use on a flat, relatively smooth, stable and non-slippery surface. Do not use the stroller in snowy, windy days or wet road to avoid the stroller or guardian from slipping.
- Only use original accessories and parts that have been approved by the manufacturer. Do not make any modifications to the product.
- Do not use the stroller in lightning days to avoid thunder stroke.
- Do not attach other accessory like buggy board on the main body during a child being carried in stroller, otherwise accident or damage to stroller may happen.
- Do not use the stroller on public vehicles.
- Lift front wheels and pay particular attention to gaps or ditch when crossing rail road.
- No continuous use for a long period: Continuous use for a long period of time may exhaust baby. No continuous use of more than 2 hours for a baby in a reclined seat and 1 hour in an upright seat.
- When feel jammed, please do not forcibly fold the stroller to prevent from any damage. You should reopen the stroller to check and operate again.
- Turn swivel wheels to inner side and lock up before folding the stroller. Improper position may cause stroller becoming imbalanced after folded.
- Do not put things that are too sharp or too large into the basket since it may cause damage to the basket.
- Please regular cleaning and checking the stroller. Only use neutral detergent to clean the stroller body.
- Make sure no oil or lubricant is left on parts such as front guard or armrest where baby may have chance to lick.
- Please contact customer service center (or local distributor) for replacement if you find the tyre wear seriously affect movement.
- Parking device shall be engaged when placing and removing the children.
- Any load attached to the handle and/or on the back of the backrest and/or on the sides of stroller will affect the stability of the stroller.
- Only replacement parts supplied or recommended by the manufacturer/distributor shall be used.
- Fasten the safety belt securely, but do not have it too tight.



CAUTION (Incorrect operation may cause injury or component damage)

- Do not hold the front guard to lift the stroller while a child seated. Failure to comply may cause the stroller to fold up suddenly, release the front guard accidentally, or cause the stroller to slip off.
- When taking an escalator, avoid the wheel being pinched in the gap between the platform and the stair.
- When the child's foot comes into contact with the floor or the wheel, stop using the stroller lest it be hurt.

重要-使用前請詳細閱讀本說明書並妥善保存作日後參考之用

警告 (錯誤操作可能引致重大傷害或死亡)

不按照本使用說明書指引使用手推車，可能對幼兒造成重大傷害。
幼兒的安全是您的責任。

- 本產品適用於一個月初生兒至15公斤（大約三歲）的幼兒。符合歐洲標準化委員EN1888安全規定和台灣CNS 12940國家標準。
- 停止手推車時，請使用停車鎖。
- 不論有否承載嬰兒，停車時勿過分信賴停車鎖的性能。
- 即使已使用停車鎖，如載有嬰兒，應隨時留意手推車附近，以防任何危險發生。
- 切勿將小配件放近幼兒，以免幼兒吞下而造成窒息的危險。
- 為了防止幼兒窒息的危險，在拆開包裝後，請將塑膠袋之類的包裝物料丟棄。
- 過分超載，錯誤折疊以及使用未經認可的附件會對手推車造成損壞。
- 乘載幼兒時必須系上安全帶，安全帶包含中央帶，腰帶和肩帶。前護欄不能防止幼兒從座墊上站起來。請確認安全帶沒有松脫，以免幼兒突然跌出手推車。
- 為防止幼兒突如其來的動作令其跌出手推車，即使已經扣上安全帶，也請經常留意幼兒，小心使用。
- 肩帶扣在插扣片上時，請勿交叉肩帶，以免肩帶對幼兒頸部造成壓迫。
- 請勿使用已破損的座墊，以免座墊不能發揮其應有功能，或令幼兒誤吞內裡的棉花等。
- 座墊起保護作用，推車未安裝座墊時禁止兒童使用，否則可能有造成傷害的風險。
- 當兒童乘坐時，看護人不要離開。
- 使用前一定要確認開關鎖已鎖上，否則手推車會有突然折起的危險。
- 不要讓幼兒操作前護欄以免其意外跌倒。
- 不可讓幼兒站立在車上，這是十分危險的。
- 切勿把身體靠於或把重物掛於把手上。
- 切勿懸掛物件（康貝原廠的配件除外）於車篷或把手上，以免引致手推車翻倒。
- 切勿承載超過一名幼兒，或讓幼兒坐在座椅以外的地方。
- 承載超重會容易產生不穩定的危險情況，產品最大承載重量：15公斤，置物籃最大承載重量：5公斤。
- 禁止於樓梯間使用手推車。
- 不要讓幼兒操作手推車，以免手推車翻倒或發生其他意外。
- 開關手推車或調節座席靠背角度時要注意四周旁人及小孩，以免夾傷指頭。
- 開關或調節手推車時，請勿讓幼兒的手接觸活動零件部分。
- 對還未能坐直的幼兒，切勿使用直立角度，請以最平躺角度使用。
- 推動手推車時請勿奔跑，應慢慢步行，以免轉向輪損壞，或引致翻倒等意外。
- 打開幼兒手推車時不要讓他人接觸，以免意外夾傷。
- 在座席使用的肩帶穿孔和座墊的肩帶穿孔位置要一致。如使用座席的上方肩帶穿孔，座墊亦同樣要使用上方肩帶穿孔，不然肩帶有可能因長度不足系緊幼兒。
- 一邊推行一邊調整座席角度是非常危險的，請勿同時進行。
- 推行時請注意路面狀況，不要讓手推車卡入排水溝蓋的縫隙中。

重要-使用前請詳細閱讀本說明書並妥善保存作日後參考之用

警告 (錯誤操作可能引致重大傷害或死亡)

- 不應在無人照顧下把嬰兒獨留於嬰兒車內，以免發生危險。
- 使用手推車前請確保推車所有鎖定裝置都已處於鎖定狀態，如安全帶長度調整，座墊扣環扣上，推車已完全展開。
- 為了防止孩子跌落，孩子乘坐時必須系上安全帶。
- 當靠背角度少於150度時，不適合6個月以下幼兒使用。
- 在把手上放置任何負載都會影響車輛的穩定性。
- 使用前，請先檢查嬰兒車與所有附件已正確安裝。
- 此產品不宜於跑步或溜冰時使用。
- 請勿讓小孩玩耍本品。
- 為避免傷害，當產品在折疊和展開時，請確保你的孩子遠離產品。
- 使用時應遠離高溫、火源、水池或電源等鄰近範圍。
- 請勿使用未經製造商認可的附屬物。請勿使用非原廠供應的零件替換或自行改裝手推車。

注意 (錯誤操作可能引致受傷或元件損壞)

- 安裝座墊時，請確保所有帶扣等已經裝好，以免引致意外或造成損壞。
- 在已承載幼兒的狀態下調整座席角度時，請先將肩帶調松，然後以另外一隻手支持著靠背調節，請注意勿讓座席角度突然改變。
- 調整座席角度後，請重新調整安全帶至適當長度。
- 除開折手推車外，請勿觸碰開關掣。
- 當操作開關時，請注意及避免可裝拆的座墊、手推車的安全帶、被子及玩具夾在手推車車體上。
- 當越過不同段差時，若強行附加力量於前車輪上使之與段差碰撞，可能引起手推車損壞和故障，當越過段差時，即使是微小段差區的地方也應減緩推行，並踏上後腳支桿及往後按下把手往前行，確保前車輪越過段差才可通行。推行時請注意自立桿和段差台的碰撞。
- 當幼兒乘坐時，請勿在手扶梯上使用或搬動手推車。
- 使用者必須對本產品作定期保養。
- 每次使用前請檢查配件是否在運輸過程中被損壞。
- 請勿將手推車作承載幼兒以外的用途，否則會引致損壞。
- 請勿用力拉動、扭動、壓下前護欄，以免引致損壞。
- 假如放低椅背使用時座位太窄，可以將靠背調高一點使用。但注意幼兒應已差不多能獨自坐直，才可這樣使用。
- 請勿讓成年人坐上手推車，或在上面放置重物，以免損壞手推車。
- 夏天使用時，戶外的天氣和路面情況會令手推車溫度提高，應避免連續長時間使用。
- 避免將手推車存放於高溫，接近熱源的地方或車廂內，因高溫可使手推車損壞或變形。
- 請定期檢查所有螺絲是否上緊。
- 有關火車上的使用：
本產品並非以火車上的使用為目的所設計的產品。假如閣下自行決定於火車上使用，請小心注意，並鎖上停車鎖，以免轉彎或剎車時令手推車翻倒。
- 請勿在提起手推車的狀態下按下開關掣，以免引致元件損壞。
- 收起手推車前請先確認置物籃內的物品已取出。
- 收折前請先確認車篷已經完全收起，以免引致組件損壞。
- 收起手推車時，請避免橫放，或於上面置放重物，以免車篷變形。
- 請勿手執開放的前護欄來拖動手推車。
- 即使已經鎖上停車鎖，手推車也有可能意外滑動或翻倒。
- 即使幼兒不在車上，也不可將手推車隨意放在路旁或斜坡等危險地方。
- 不可於斜坡、階梯、自動扶梯、顛簸坡道、沙灘、泥地等場所使用手推車。
- 推動手推車時請小心路上凹陷之地方，以免前輪意外陷進溝內令手推車翻倒。
- 如手推車出現損壞或操作問題，應立即停止使用，並將其存放在遠離幼童的地方。
- 請勿將本產品放近樓梯或梯級上。
- 只可在乾燥的平地上使用。請勿於雪地和強風時或濕滑路面上使用，以免令手推車或監護者意外翻倒。
- 如發現手推車損壞，請聯絡分銷商。
- 請勿於打雷時使用手推車，以免意外遭受雷擊。
- 請勿外加任何以輪板或元件於主體上承載幼兒，以免對手推車造成損壞。
- 請勿於公共汽車上使用手推車。

注意 (錯誤操作可能引致受傷或元件損壞)

- 跨越火車軌和汽車道的十字道口等時，請提高前輪跨越間隙，以免前輪意外卡在溝內。
- 禁止連續長時間使用：連續長時間使用會對幼兒造成負擔。躺臥姿勢的連續使用時間上限為2小時，坐著姿勢的則為1小時。
- 感覺有異物卡住時，請勿強行折疊，以免造成損壞。應先打開手推車，確認後再操作。
- 收折前請將轉向輪翻往內側然後鎖定。如果不將轉向輪鎖定在內側位置，收折後手推車將較易翻倒。
- 請勿承載太尖或太大的東西於置物籃中。
- 請定期清潔以及檢查手推車。請勿使用非中性的潔劑清潔車架。
- 請注意勿讓油分附在幼兒有機會舔到的地方，如前護欄、扶手等。
- 如發現車輪外胎磨耗嚴重，影響推行，請聯繫客服中心(或當地分銷商)進行更換。
- 當放置和移開幼兒時請鎖定停車裝置。
- 為了手推車的穩定性，請勿將其他產品連接到推把、靠背的背部、手推車的側面等部位。
- 請牢牢系上安全帶，但注意不要過緊。
- 切勿搬動承載了嬰孩的手推車，以免手推車突然收折。或手執前護欄等地方搬動手推車，以免手推車意外滑脫或令前護欄松脫以致手推車掉下。
- 在乘降時，請注意不要將手推車車輪夾入月臺與電梯的段差間隙中。
- 當幼兒的腳接觸到地面和車輪時，請勿使用手推車，有可能造成腳受傷。
- 假如幼兒頭部超出靠背前端時，請勿使用躺臥角度。

List of components 部件清單

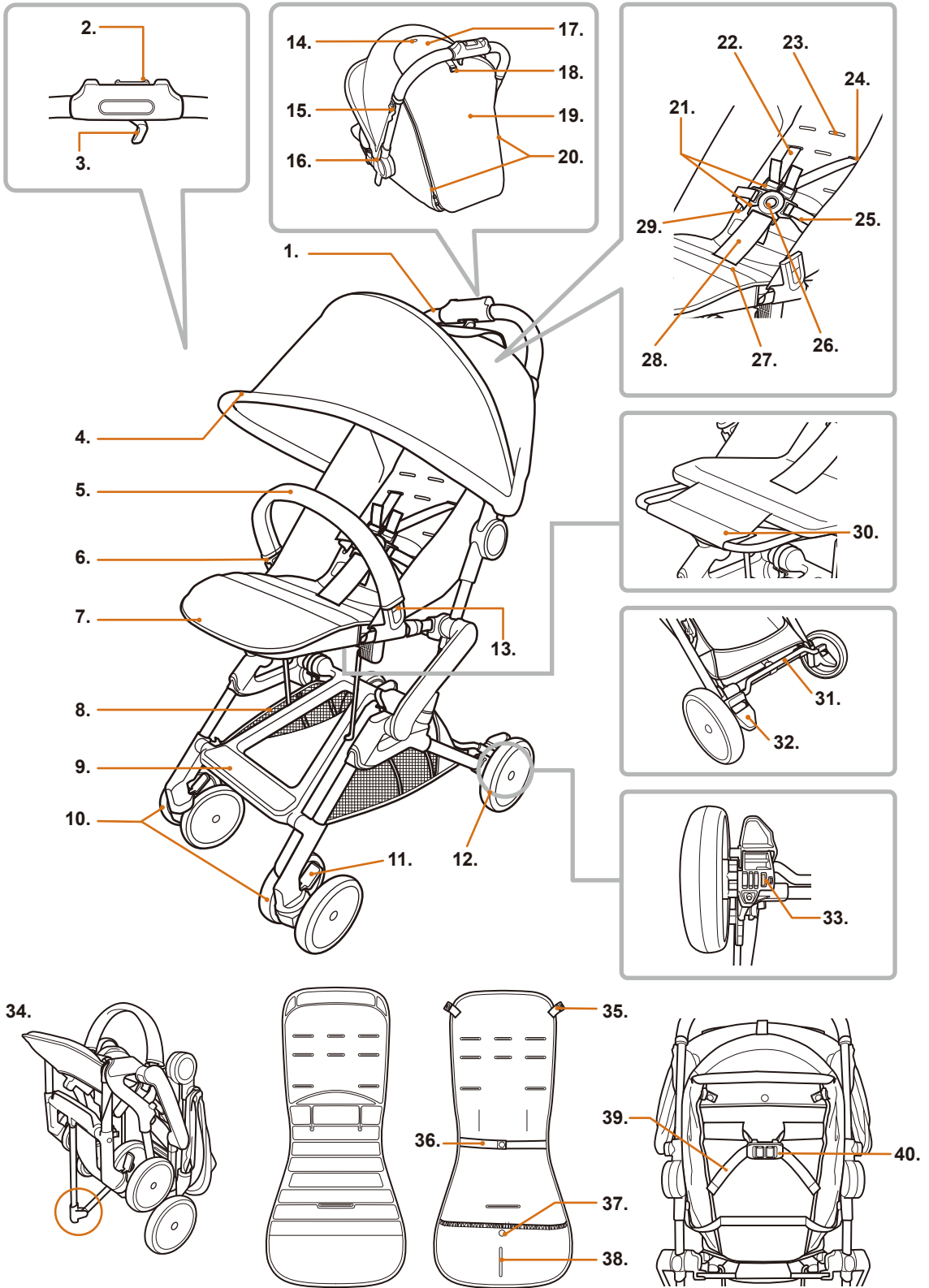

List of components

- | | | |
|------------------------|---------------------------------|-------------------------------------|
| 1. Handle | 17. Window cover | 29. Waist belt insert outlet |
| 2. Safety Lock | 18. Airthrough window snap | 30. Extension bar |
| 3. Folding lever | 19. Airthrough window cover | 31. Parking brake stay |
| 4. Canopy | 20. Fastener | 32. Stopper |
| 5. Front guard cover | 21. Shoulder/Waist belt buckle | 33. Rear wheel quick-release button |
| 6. Front guard | 22. Shoulder belt | 34. Self-supporting rod |
| 7. Seat cushion | 23. Head support insert outlet | 35. Installation belt(upper) |
| 8. Basket | 24. Shoulder belt insert outlet | 36. Installation belt(middle) |
| 9. Step | 25. Waist belt | 37. Cushion Snap |
| 10. Front Wheel | 26. Crotch belt buckle | 38. Cushion opening |
| 11. Swivel wheel lock | 27. Crotch belt insert outlet | 39. Reclining belt |
| 12. Rear Wheel | 28. Crotch belt | 40. Reclining buckle |
| 13. Front guard button | | |
| 14. Snap | | |
| 15. Metal button | | |
| 16. Canopy rubber belt | | |

部件名稱

- | | | |
|-------------|------------|------------------|
| 1. 把手 | 17. 天窗蓋 | 33. 後輪快拆按鈕 |
| 2. 安全鎖 | 18. 透氣窗插扣 | 34. 自立桿 |
| 3. 開關掣 | 19. 透氣窗蓋 | 35. 座墊固定帶 (上部) |
| 4. 車篷 | 20. 拉鍊 | 36. 座墊固定帶 (中部) |
| 5. 前護欄套 | 21. 肩腰帶插扣片 | 37. 座墊固定扣 |
| 6. 前護欄 | 22. 肩帶 | 38. 座墊開口 |
| 7. 座墊 | 23. 護頭墊穿孔 | 39. 靠背角度調節帶 |
| 8. 置物籃 | 24. 肩帶穿孔 | 40. 靠背角度調節扣 |
| 9. 腳踏 | 25. 腰帶 | |
| 10. 前輪 | 26. 中央帶扣 | |
| 11. 轉向輪鎖桿 | 27. 中央帶扣穿孔 | |
| 12. 後車輪 | 28. 中央帶 | |
| 13. 前護欄松脫掣 | 29. 腰帶穿孔 | |
| 14. 車篷天窗鈕扣 | 30. 腿部延伸桿 | |
| 15. 車篷固定金屬扣 | 31. 後剎車桿 | |
| 16. 車篷固定鬆緊帶 | 32. 停車鎖 | |

Checking the sales package 開箱確認

Check if any part is missing after opening the sales package.

請於開封後確認所有部品是否齊全。

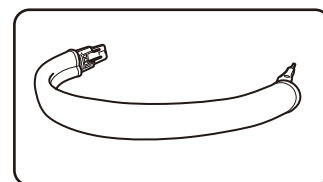
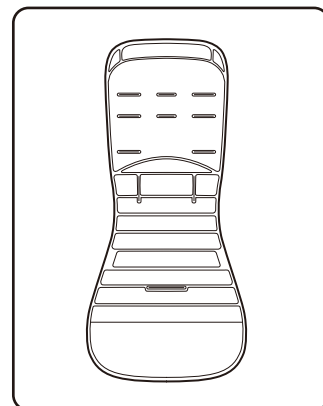
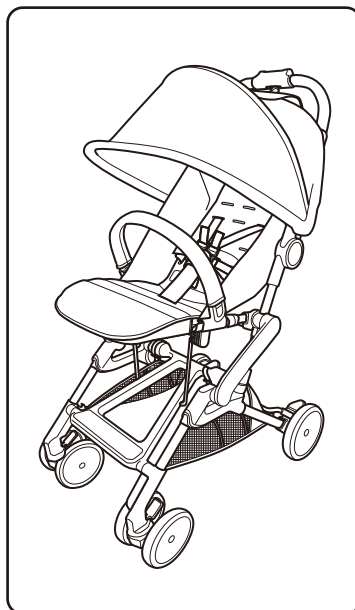

Before Use 手推車使用前

To minimize cloth wrinkles during packaging and transportation, the buttons, elastic and zippers of the canopy are unfastened. After unfold the frame, assemble the canopy in the following procedures:

- ① Lead the metal button on the upper part of the canopy through the buttonhole of the handle.
- ② Hook the elastic at the canopy bottom to the connector. And the elastic belt is clamped into the groove of connector.
- ③ Zip up both sides zippers on the back of the canopy.

為了減少包裝運輸中布料產生的褶皺，故將車篷部分的扣子、鬆緊帶、拉鍊在解開的狀態下包裝。消費者打開車架後請按照下面的順序安裝。

- ① 將車篷上部的金屬扣子扣到把手的扣眼上。
- ② 將車篷根部的鬆緊帶掛到接頭上，並將鬆緊帶卡入接頭的小槽內。
- ③ 將車篷後部左右的拉鍊拉上。

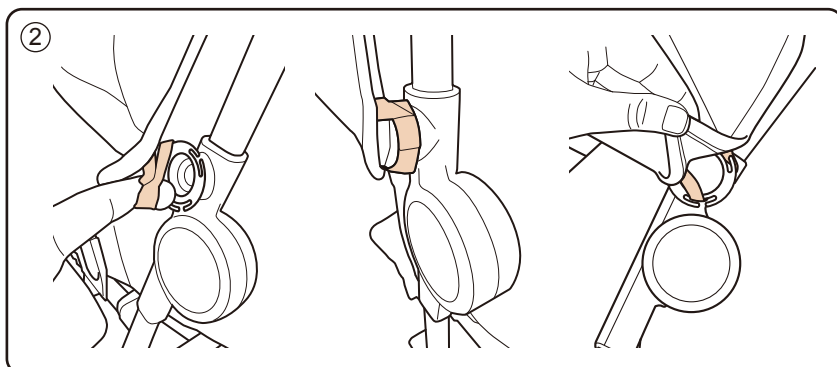
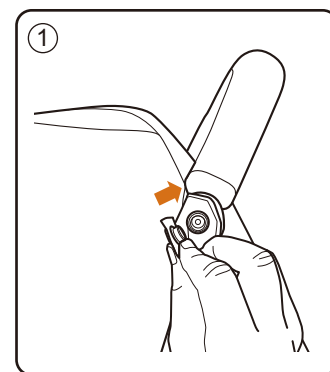

Unfolding the triple - folded stroller 打開手推車 (三折疊時)

- ① Slide the safety lock as demonstrated direction and hold it in place.
- ② While holding the folding lever, lift the handle. Lift the stroller slightly and press the handle backward until it clicks. Then the stroller stretches out completely.

CAUTION: When unfold the stroller, always hold the safety lock and the folding lever till the stroller body is unfolded completely.

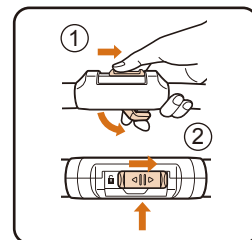

- ① 將把手上的安全鎖向箭頭方向滑動並握住。
- ② 同時握著並提起開關掣，稍稍提起手推車並用力向後下壓把手，聽到“咔嚓”一聲表明已完全打開。

注意： 打開手推車時，請一直按住安全鎖和開關掣，直到完全將手推車打開為止。

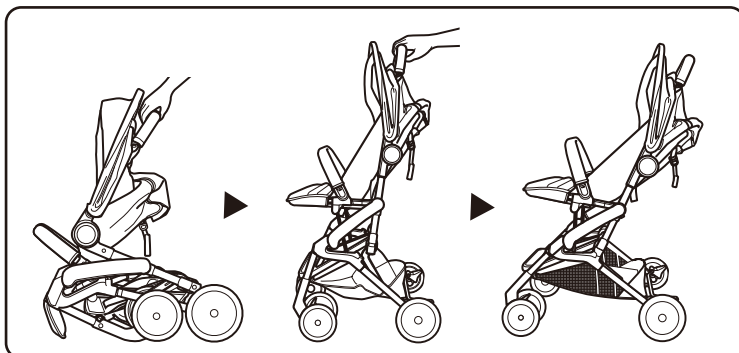

Using the swivel wheels 使用轉向輪

- ① Lift the swivel wheel locks to fix the direction.
- ② Press down the swivel wheel locks and the wheels can turn to every direction.

- ① 向上推起前輪轉向輪鎖，即可固定車輪前行方向。
- ② 用手按下前輪轉向輪鎖，車輪可自由轉向，改變推行方向更容易。

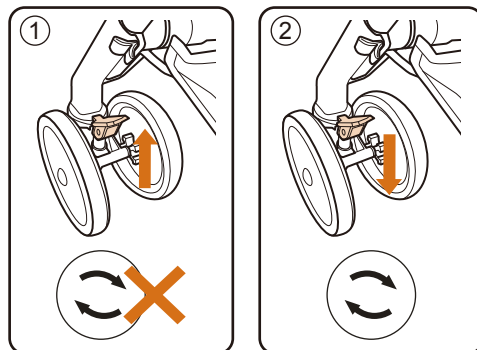

Using the stopper 使用停車鎖

- ① Press down the stopper to activate the parking brake.
- ② Push the parking brake stay down to release the parking brake.

WARNING: Always engage the stoppers when you leave the stroller.

- ① 按下左右兩邊的任意一停車鎖即可固定手推車於原位。
- ② 用腳踩下后剎車桿，即可解除停車鎖。

警告： 在遠離手推車時，請時刻謹記使用停車鎖。

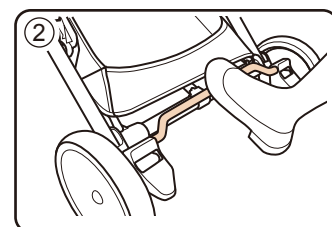
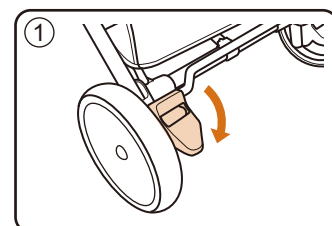

Using the extension bar 使用腿部延伸桿

Apply the extension bar for better comfort when child is asleep.

① To use the extension bar, pull it out under the seat from the opening below the seat cushion.

② Retract the extension bar under the seat when not in use.

Note : To prevent any finger from being clamped between the extension bar and the seat tube during operation, a certain space is left there between in design, so that extension bar can not be fully retracted under the seat tube. Users should take heed of this.

使用腿部延伸桿，可以使幼兒睡覺時姿勢更舒適。

① 使用腿部延伸桿時，從座墊下方開口處將座席下的腿部延伸桿抽出即可。

② 不使用時請將延伸桿推回座席下方即可。

小提示：為了防止操作時手指不被夾於腿部延伸桿和座席管之間，產品設計時在這兩者之間保留了一定的間隙，且延伸桿並不能完全被推入座席管下，此點請注意。

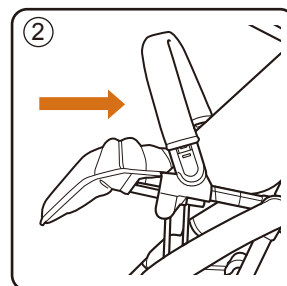
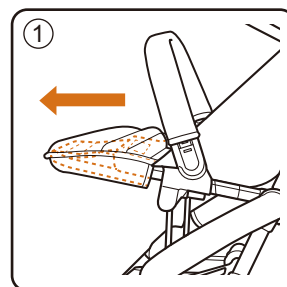

Open front guard 打開前護欄

① Press and hold the button at the end of the front guard as illustrated.

② Detach the front guard.

To fasten the guard, align the front guard to the socket and insert it. Pull the guard to check whether it is securely locked.

WARNING : Do not hold the front guard to lift the stroller while a child seated.

① 按下圖中箭頭所指處的前護欄松脫掣按鈕。

② 抽起前護欄。

要扣上護欄時，請將前護欄對準插口，然後插入安裝。用手拉一拉確認是否鎖定牢固。

警告：小孩乘坐時，請勿手執前護欄搬動手推車。

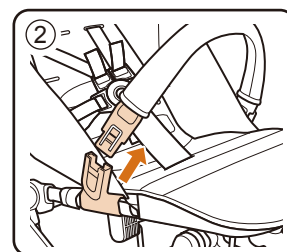
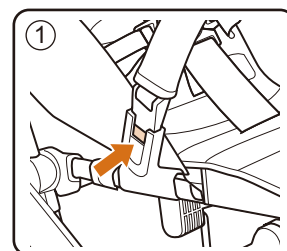

Detach the front guard cover 拆除前護欄套

Release the front guard and detach the cover from the front guard.

打開前護欄，從護欄上取下護欄套。

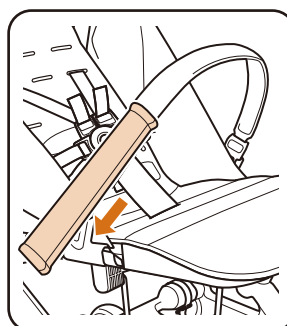
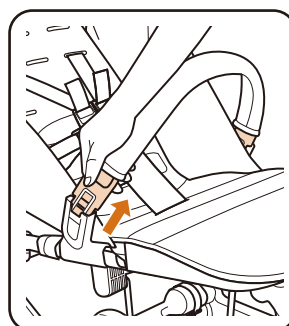

Adjusting the covering size of canopy 車篷大小的調節

- ① Hold the canopy stay and pull the canopy backward for reduced canopy coverage.
- ② Hold the canopy stay and pull the canopy forward for full coverage.

- ① 用手拉住車篷前支桿向後調節，即可收攏車篷。
- ② 用手拉住車篷前支桿向前調節，即可展開車篷。

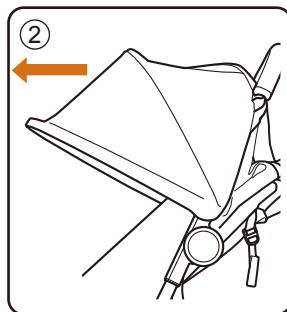
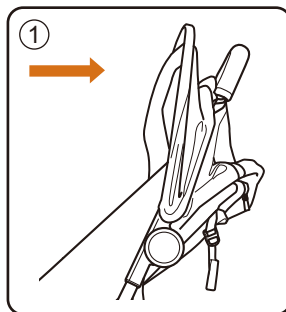

Top window 使用天窗

- ① Open top window by releasing snap.
- ② Fasten the snap to close top window.

- ① 打開天窗時請將鈕扣解開，將天窗蓋子向後翻開即可。
- ② 關閉天窗時則將扣子重新扣上即可。

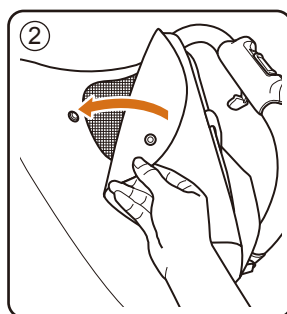
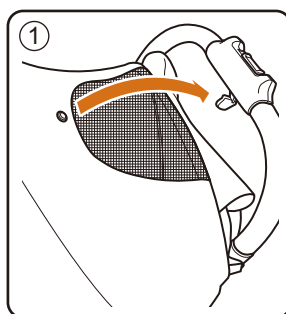

Using the airtrough window 使用透氣窗

- ① Unzip the zips on both sides at the back of the canopy.
- ② Roll up the canopy cover at the back end. Buckle it up.

WARNING : To use the canopy ventilation window, make sure the rear window cover are rolled up and buckled up before using. Otherwise, the cover may overspread the child's face and cause suffocation.

- ① 解開車篷後兩邊的拉鍊。
- ② 將後車篷蓋往上卷，扣上卡扣。

警告：使用車篷透氣窗時，請務必將後窗蓋子卷上並用扣子扣好後再使用。透氣窗蓋沒有卷起扣住的情況，蓋子可能會遮住小孩的脸而造成窒息。

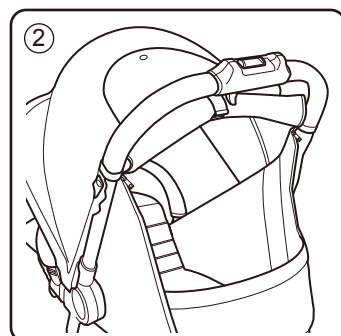
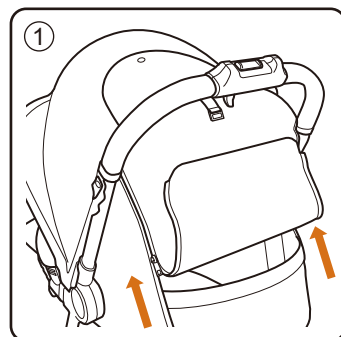

Using safety harness 使用安全帶

- ① Seat the child into the stroller and fit the shoulder belts on the child's left and right shoulder.
- ② Shoulder and waist buckles are overlapped.
- ③ Pull out the crotch belt and put the insert plastics into the buckle until a "Click" sound is heard. Pull the shoulder belts and waist belts to check if it is secured.
- ④ Press the crotch buckle button to release the harness.

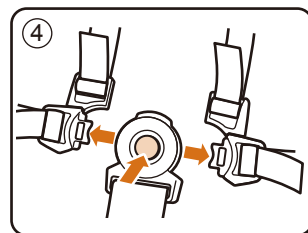
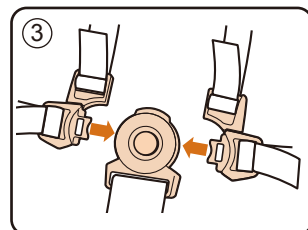
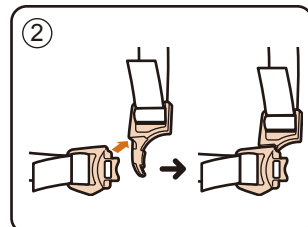
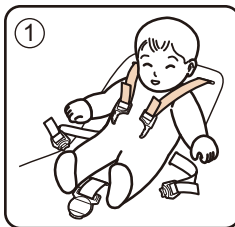

WARNING

: Always use the restraint system.

Note : Adjust the length of seat belt properly after change of the backrest angle.

- ① 讓孩子坐在車內，使其肩膀左右與肩帶貼合。
- ② 將肩帶扣和腰帶扣重疊。
- ③ 拿起肩腰帶扣左右插入中央帶扣，聽到“咔嚓”一聲，說明已安全插入。拉動中央帶，腰帶和肩帶確認有無鬆動。
- ④ 若要解開安全帶，按下中央帶扣中間的按鈕即可解除。

警告：任何時刻都必須使用安全帶。

小提示：當改變靠背角度時，請謹記檢查並確認安全帶已作出最適當的調整。

Adjusting the waist/shoulder belt length 調節肩帶、腰帶的長度

- ① Pull the waist belt end as shown direction A to shorten.
- ② Loose and pull out the waist belt as shown direction B, then pull it inward to extend the length as shown direction C.

Use the same method on waist belt to adjust the shoulder belt.

NOTE: Always leave at least 3cm at the belt end.

- ① 收緊時，將腰帶的前端位置往圖標箭頭A方向拉。
- ② 延長時，將腰帶表側往B箭頭方向鬆脫出來，然後再將腰帶向里側往C箭頭方向拉。

肩帶的調節方法同腰帶的調節方法一致。

小提示：注意腰帶末端應留下3cm以上的長度。

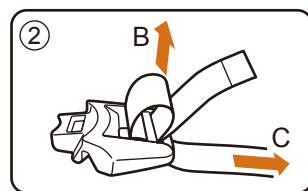
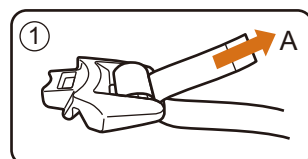

Adjusting the crotch belt 調節中央帶時

Tightening - ① Pull the crotch belt end as shown direction.

Extending - ② Follow the direction of arrow and pull out the belt to end.

③ Follow the direction of arrow and pull the belt to the end.

收緊中央帶時，如圖 ① 拉出中央帶內側的安全帶到最末端，為最短狀態。

延長時，如圖 ② 箭頭方向拉出中央帶末端安全帶後按照圖 ③ 箭頭方向拉到底，為最長狀態。

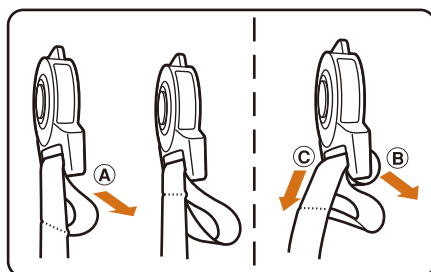

Attaching the insert plastics 將肩帶、腰帶裝到插扣片上

- ① Use the waist belt end to pass through from the buckle back slot (C) and slide out to slot (A).

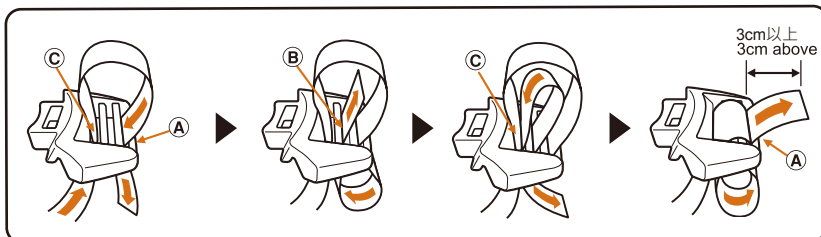

- ② Pull out the waist belt end from slot (B).

- ③ Slide out the waist belt end through slot (C).

- ④ Pull out the waist belt from slot (A) and adjust the applicable length. (Leave 3cm or above)

- ① 將腰帶前端從穿孔 (C) 穿出再通過孔 (A) 拉出。

- ② 將腰帶前端通過穿孔 (B) 拉出。

- ③ 將腰帶前端再向穿孔 (C) 通過。

- ④ 最後將腰帶向穿孔 (A) 拉出，並調至到合適的長度。(末端保留3cm以上)

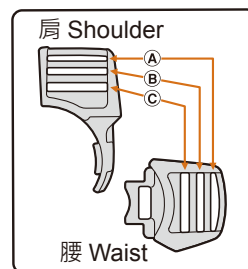

Reclining the backrest 調節靠背角度

- ① Recline - Support the backrest with one hand then pull down the seat reclining buckle.

- ② Upright - Pull the reclining belt by both hands at the same time.

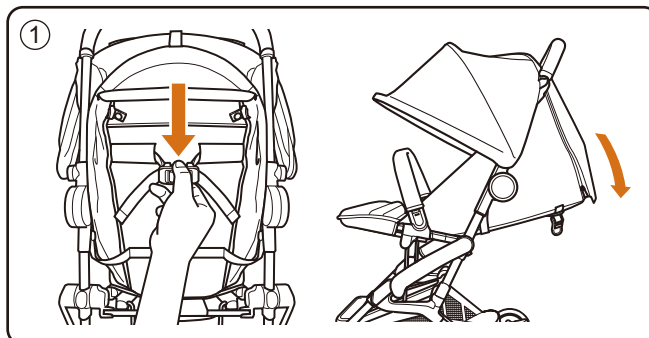

- ① 調低靠背角度時，先以單手支撐著小孩身體，然後將角度調節扣往下拉調低靠背。

- ② 調高靠背角度時，將兩條角度調節帶往左右拉使角度調節扣往上即可。

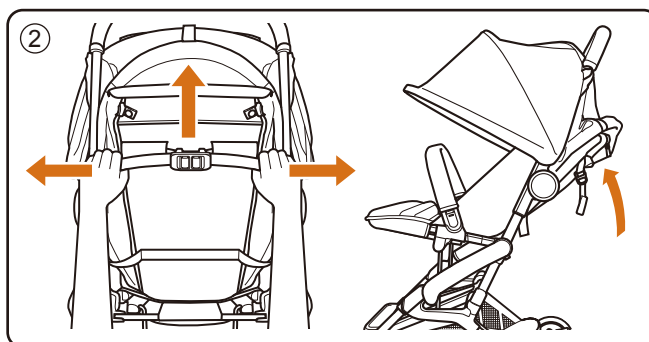

Folding the stroller 收折手推車

The stroller can be folded into three or two segments.

Triple folding method 1

- ① Slide to release the safety lock of direction as illustrated.
- ② While holding the folding lever, lift its handle slightly forward. After that, the rear wheel will rise and the front wheel will slide to the body. When the self-supporting rod can be seen, bend the handle backward. The stroller will be folded up.

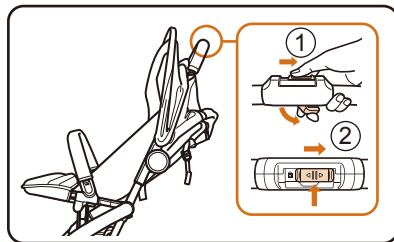

The stroller can stand itself after being folded up.

CAUTION : The stroller may get stuck when being folded up. Do not swing the stroller forcefully in this case. Try to tilt the handle forward. When the self-supporting rod can be seen and the handle is automatically folded up backward, the stroller will be folded up.

CAUTION : When this method is used to fold the stroller, the sewing parts may come into contact with the floor and get contaminated. If so, please wipe it clean before using and remind the user of it.

When this method is used to fold the stroller, scratches may be left on the plastic parts of the front wheel sets after the stroller being repeatedly folded. However, such scratches will not affect the use of the stroller.

Note : After being folded up, the front guard can be used as a lift handle for easy transportation.

Note : Tuck up the canopy and the backrest before folding up the stroller.

本手推車既可以三折疊也可兩折疊，具體操作說明如下。

三折疊操作方法1

- ① 如圖中箭頭方向拉動安全鎖作解除。
- ② 同時一邊握住開關掣，一邊提起把手稍稍向前，此時後輪浮起，前輪向身體側滑動，直到能看到自立桿，向後彎下把手，推車會被折疊起來。折疊後推車可以自立。

注意 : 收折時可能有推車被卡住而不能順利折疊的情況，此時請不要大力甩動手推車，請試著將把手向前傾，直到能看到自立桿，且把手自然往後折疊，推車就折疊起來了。

注意 : 此種方法收車時，座墊前端會碰到地面而被弄髒，請注意。此種方法收車時，前輪組塑膠件因為會和地面碰到，可能在多次折疊後出現刮花但不影響使用。

小提示：收折手推車前請先將車篷和靠背收攏。

小提示：收折後可以將前護欄作為提手，方便攜帶提行。

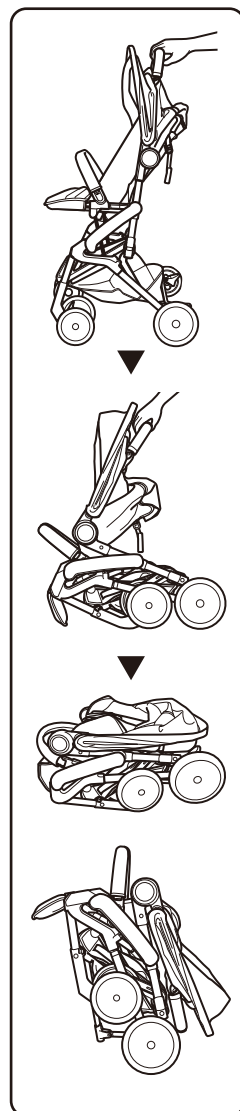

Folding the stroller 收折手推車

Triple folding method 2

- ① Slide to release the safety lock of direction as illustrated.
- ② While holding the folding lever, press its handle downward to raise the front wheels and tuck them up. Once the self-supporting rod touches the floor, bend the handle backward. The stroller will be folded up. The stroller can stand itself after being folded up.

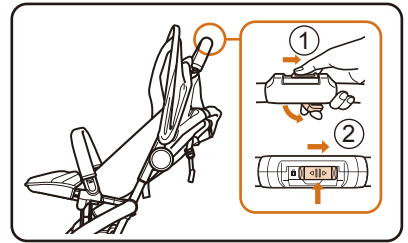

Note : Tuck up the canopy and the backrest before folding up the stroller.

Note : After being folded up, the front guard can be used as a lift handle for easy transportation.

三折疊操作方法2

- ① 如圖中箭頭方向拉動安全鎖作解除。
 - ② 同時一邊握住開關掣，一邊下壓把手，使前輪翹起，並收攏前輪，待自立桿觸地後再向後彎下把手，推車會被折疊起來。折疊後推車可以自立。
- 小提示：收折手推車前請先將車篷和靠背收攏。
小提示：收折後可以將前護欄作為提手，方便攜帶提行。

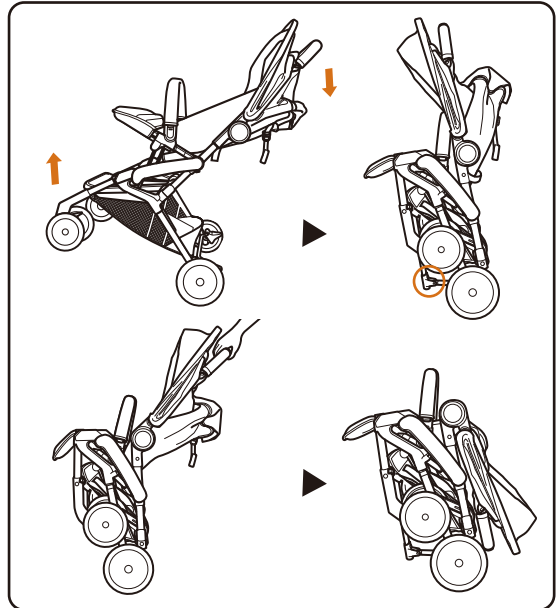

Dual folding method

- ① Slide to release the safety lock of direction as illustrated. While holding the switch, press its handle downward to raise the front wheels.
- ② Then the stroller will be folded up. The stroller can stand itself after being folded up. Stroller folded up in this way can be towed, making the movement more effortless. The stroller will be folded up. The stroller can stand itself after being folded up.

WARNING : When Folding the stroller, please ensure your child and other children are kept at a safe distance .Please ensure that they are not in contact with mounting parts and remove all items from the basket before folding the stroller.

Note : Tuck up the hood and the backrest before folding up the stroller.

Note : Stroller folded up in this way can be towed, making the movement more effortless.

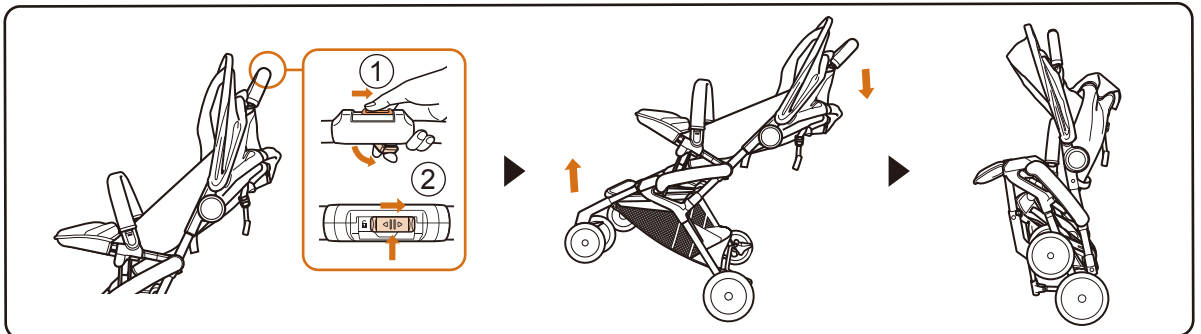

Folding the stroller 收折手推車

兩折疊操作方法

- ① 如上頁圖中箭頭方向拉動安全鎖作解除。
- ② 同時一邊握住開關掣，一邊向後下壓把手抬起前輪，推車會被折疊起來。折疊后推車可以自立。

警告：在收折手推車前，請確保與幼兒保持安全的距離，請勿讓幼兒觸及活動零件，並從置物籃中取出所有物品。

小提示：收折手推車前請先將車篷和靠背收攏。

小提示：此折疊方法方便拖行，不必整車拎起，出行更輕鬆。

Unfolding the dual-folded stroller 打開推車(兩折疊時)

- ① Slide to release the safety lock of direction as illustrated.
- ② While holding the folding lever, lift the stroller to stretch it out.

- ① 如圖中箭頭方向拉動安全鎖作解除。
- ② 同時一邊握住開關掣，稍稍提起推車並用力向後下壓把手，聽到“咔嚓”一聲表明已完全打開。

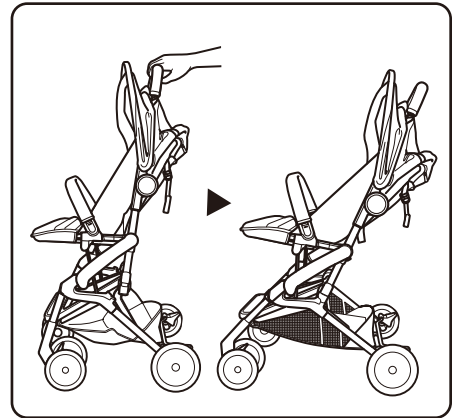
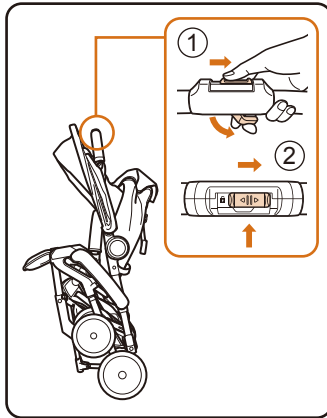

Removal/Assembly of Rear Wheels 後車輪的裝拆方法

- ① To remove the rear wheel, press the button at the bottom of stopper and pull out the rear wheels with little force.
- ② Line up the tab on rear wheel axle with the groove in rear wheel housing. You will hear the "click" when the wheels are locked in place.

WARNING : After assembly, please be sure to check the wheels are securely attached by pulling outwards.

- ① 拆除車輪時，請按下圖中所示的停車鎖下方的快拆按鈕，將車輪拉出即可。
- ② 安裝時將輪軸對準插孔插入即可。

警告：車輪安裝後，請務必向外拉動車輪以確認車輪是否安裝牢固。

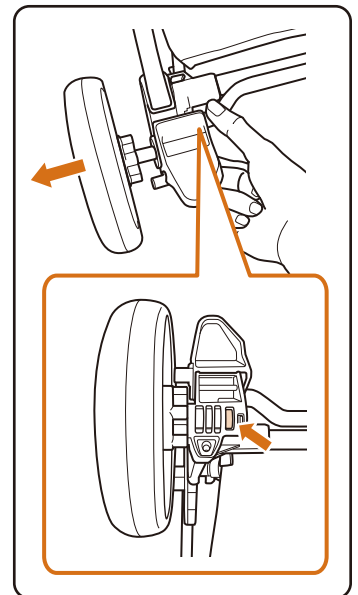

Basket 置物籃

The basket can carry a maximum weight of 5kgs.

You can attach and remove the belts and snaps according to step ①, ②, ③, ④.

CAUTION : Never place any glassware or fragile articles in the basket lest they be damaged. Place the articles in the basket as evenly as you can, thus making them bear even load.

置物籃的最大載重量是5kg。

使用安裝帶並按照 ①, ②, ③, ④ 安裝或拆除置物籃。

注意 : 玻璃製品和易碎物品請不要放入置物籃中，以免物品破損。請盡可能的讓物品均勻的放入置物籃中，使其受重均勻。

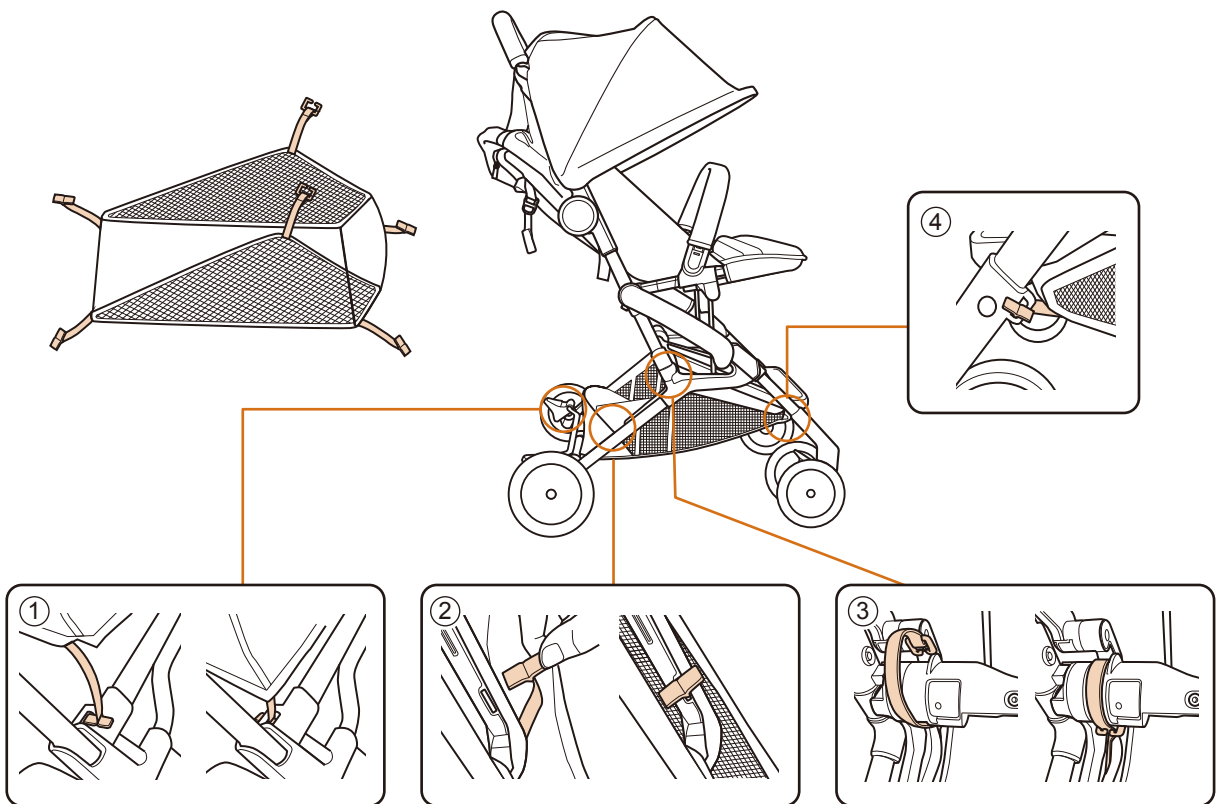

Detaching the seat cushion 座墊的拆除方法

- ① Press on the buckle button to release the insert plastics.
- ② Loosen the snaps (upper) on both sides of seat cushion from seat back (2 places).
- ③ Loosen the snaps (middle) on both sides of seat cushion from seat back (1 place).
- ④ Release the snaps as illustrated. Then remove the seat cushion from seat back. To install seat cushion, go in the steps reverse.

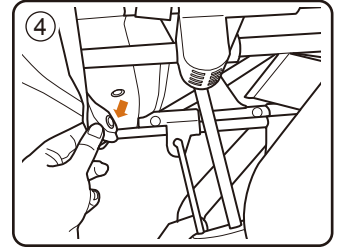
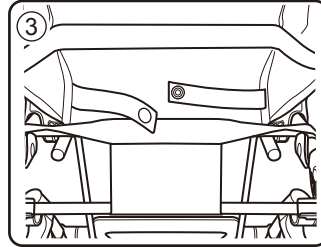
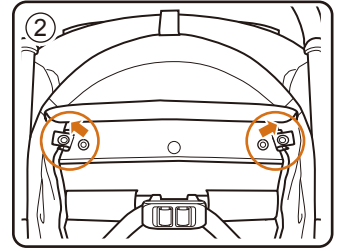
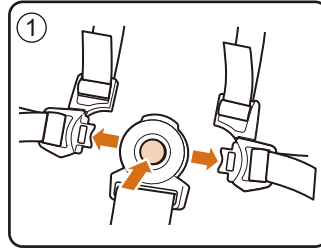

WARNING :

Seat cushion can play a protective role. When the stroller is not installed with a seat cushion, please stop using the stroller. Otherwise, there may be risk of injury.

- ① 按下中央帶扣按鈕解開安全帶。
- ② 將座墊上部的扣子從靠背上解開（2處）。
- ③ 將座墊中間的扣子解開（1處）。
- ④ 按圖將坐席前端下方的扣子解開。抽出座墊。
安裝時請以逆序進行。

警告：座墊起保護的作用，推車未安裝座墊時禁止兒童使用，否則可能有造成傷害的風險。

Adjust shoulder belt heights 調節肩帶高度

- ① Pull out shoulder belt from seat cushion and backrest. Insert the shoulder belt through the correct slots on the backrest.
- ② Insert the shoulder belt through the correct slots on the seat cushion, make sure you use the slots in the same height.

Note : The lowest shoulder belt insert outlet should be used for children under 6 months.

- ① 先將肩帶從座墊及靠背上解除。將肩帶穿過靠背上正確的肩帶孔。
- ② 將肩帶穿過座墊上正確對應位置的穿孔，並確認兩邊穿孔在適當的高度。

小提示：當幼兒未滿六個月時，請使用最低的肩帶穿孔。

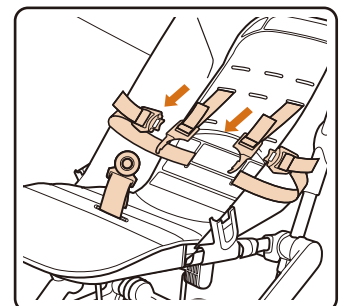
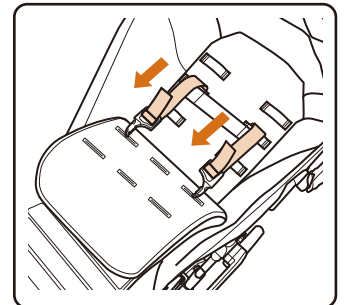

Maintenance and Cleaning 保養和清潔

- Never apply force on any mechanism or moving parts.
- To prevent mildew forming, do not store this product in a wet or humid environment.
- Avoid prolonged exposure of the product to rain or snow.
- Clean the plastic and metal parts with a wet cloth. For stubborn stains, use a diluted mild detergent.
- You may lubricate moving parts if the operation or movement of the stroller is not smooth. Do not apply excessive lubricant as it may stain with dust which may cause malfunction.
- Please do not apply any lubricating oil on open/fold lock, safety belt buckle, front guard plug, safety lock, folding lever and swiveling lock that will cause malfunction.
- 切勿強行拉動活動零件或裝置。
- 請勿將產品存放在潮濕的地方以免產品發霉。
- 避免將產品長時間暴露於雨水或雪霜之中。
- 請以濕布清潔金屬及塑膠部分。如遇頑固污垢，可使用稀釋的清潔劑。
- 若感到手推車操作或運行不順暢時，可以添加適量的潤滑劑。注意不要添加過多的潤滑劑，否則反而會容易沾上灰塵，引起操作異常。
- 注意某些部位不可以加潤滑劑，如把手操作部、座席安全帶扣、前護欄的安裝部、開閉鎖周圍、轉向輪回轉部，否則可能引起操作不良。

Cleaning and maintaining fabrics 清洗縫製品洗滌指引

- Be careful not to injure the plastics on canopy and the snaps from basket.
- Due to the characteristic of the product, the color may fade after numbers of washing.
- It is recommended to wash with neutral detergent which does not contain fluorescent brightener, bleach etc.
- Always keep clean due to the condition of storage, the mildew may be generated.
- 請注意不要損壞車篷的塑膠部分或籃子的U字鉤子等。
- 根據產品的特性，會有輕微的褪色。
- 洗滌的時候建議使用中性洗滌劑。使用含螢光劑、漂白劑的清洗可能會引起皮膚乾燥、濕疹等，所以請不要使用這類洗滌劑。
- 請小心洗滌及保持清潔，同時需確保縫製品保管於通風環境，避免發霉狀況。

Washing of the seat cushion, front guard cover, shoulder belt, waist belt 座墊、前護欄套、肩帶、腰帶的洗滌方法

- Hand wash in warm water or machine-wash gently .
- When using the washing machine, put the laundries into the washing net before washing. Otherwise a fray and damage may cause.
- After washing, please twist it gently to make it dry. Hard twist may leave folds onto the fabric.
- It is recommended to wash and spin separately with other clothes.
- Rinse thoroughly, wring out lightly, and then arrange the shape and dry in the shade.
- Do not use drying machine or dry cleaning.

- 請以溫水手洗或弱速機洗。
- 使用洗衣機的時候，請將縫製品放入柔洗袋內，避免縫製品損壞。
- 洗滌後，請輕輕地擰乾，大力擰乾的話可能會使縫製品留下褶皺。
- 部分縫製品可能會出現掉色，請跟其他物品分開清洗，另外請避免浸泡。
- 輕輕擰乾後，整理好形狀，放於陰涼處晾乾。
- 請勿使用烘乾機、熨斗及乾洗以免縫製品損壞。

Washing of the seatback, canopy, basket, crotch belt 坐席、車篷、置物籃、中央帶的清洗方法

- Do not soak into the water. Use sponge or brush wipe off the dirt with warm water.
- After wipe off the dirt by detergent, use a cloth to wipe off the excess water and detergent.
- Dry in shade area after wipe off water by dried cloth.

- 請勿將縫製品浸泡在液體中。請用海綿或毛刷擦拭污垢。
- 當使用清潔劑擦拭後，請以幹布或海綿將多餘的水分或清潔劑抹淨。
- 擦拭後請置於陰涼處陰乾。

香港和東南亞地區消費者請參考下面：

Supplier:

Combi Hong Kong Limited

Room 1003, HK Pacific Centre, 28 Hankow Road,

Tsim Sha Tsui, Kowloon, Hong Kong.

台灣地區消費者請參考下面：

- | | | |
|-----------|---|---|
| 產品名稱及型號 | : | 手推嬰幼兒車 CFS |
| 製造年份 | : | 請參考車體腳管貼紙 |
| 進口商 | : | 台灣康貝股份有限公司 |
| 地址 | : | 台北市11493內湖路一段360巷6號6樓 |
| 電話 | : | (02)7720-8585 |
| 統一編號 | : | 12946262 |
| 製造廠商 | : | Combi Holdings Limited |
| 地址 | : | Room 1003, HK Pacific Centre, 28 Hankow Road,
Tsimshatsui, Kowloon, Hong Kong. |
| 原始製造國 | : | 中國 |
| 適用年齡 | : | 一至三十六個月 |
| 最大體重 | : | 15kg以下 |
| 置物籃最大承載重量 | : | 5kg以下 |
| 主要成份或材質 | : | 鋁合金、聚酯纖維、聚丙烯 |
| 使用方法 | : | 請依說明書組合使用 |
| 注意事項 | : | 乘坐時務必繫好安全帶。 |
| 緊急處理方法 | : | 盡速送醫急救。 |

Combi Corporation

175336050