

# Combi Corporation

## Joytrip

### User Guide

- For safety of your children, please read this user guide carefully before use and use the product accordingly.
- Please keep this user guide underneath the seat base for future reference. (Refer to P.4)



This product is an approved model which conforms to regulation CNS 11497 standard.

- Universal: G1,2,3
- Applicable weight: 9-36kg

Before use

Assembly method  
Attaching the backrest  
(Please refer to page 10)

Using as  
Child mode

Using as  
Junior mode

Using as  
Booster mode

Convert to  
Child mode

Care and Maintenance

165456080





## Before use

### Before use

**Thank you for your purchase of Combi Child Car Seat. Before use, please read this user guide carefully and use your child car seat accordingly.**

Child car seat is designed to reduce the injury to the child in case of traffic accident. However, it is not necessarily a guarantee that the seat can completely protect the child from injury.

The caution items mentioned in this user guide are for your reference in order to use this product safely. [Danger], [Warning] and [Caution] labels indicate the potential consequences if the mentioned are not followed properly and are categorized according to the level of severity.

Labels	Contents of the labels.
 <b>DANGER</b>	Improper usage will directly cause death or severe injury.
 <b>WARNING</b>	Improper usage may cause death or severe injury.
 <b>CAUTION</b>	Improper usage may cause injury or damage of the product.
<b>HINT</b> 	It is the recommendation about usage of child car seat and useful hint.

# Contents

## Before use P1~P9

Before use	1
Use according to the child's weight	3
Name of parts	4
Various types of vehicle safety belts and important	5
Notes for installation	
Inapplicable vehicle seats	6
For safe use of the child car seat	7-9

## Assembly method P10~12

To attach and detach the backrest	10
Installing and using the cup holder	11
Detaching the cup holder	11
To attach and use the head support and lumbar support (EG only)	12

## Using as Child mode (9-18kg) P13~20

Preparation	13
Adjusting the shoulder belt to fit the child	13-15
Caution during installation	15
Preparation before installation	15
Preparation of the vehicle seat	16
Installation to the car	17
Secured installation method	18
Check method after installation	18
Seating the child	19-20

## Using as Junior mode (15-25kg) P21~27

Preparation	21
Switching to Junior mode	21

To detach the baby belt and buckle	21-23
To store the baby belt adjustment metal	24
Preparation of the shoulder belt positioner	25
Installing to the car	26
Seating the child	26
To adjust the shoulder belt positioner	27
Check after installation	27

## Using as Booster mode (22-36kg) P28~30

Preparation	28
Switching to Booster mode	28
Seating the child	29
To adjust the shoulder belt positioner	29
Check after installation	30

## Converting back to Child mode P30~32

To store the shoulder belt positioner	30
To attach the baby belt adjustment metal	30-31
To install the baby belt	31-32

## Maintenance P33~34

To attach and detach the seat cover on the backrest	33
To attach and detach the seat cover on the seat part	33
Washing the seat cover	34
Caring for the body and the baby belt	34



## Storage P34

Storage	34
How to dispose it	34
Angle checker	Back cover

## Use according to the child's weight

Before use

This product can be used in 3 different ways according to child's weight.

Mode	child mode	junior mode	booster mode
Using Method		→ 	→ 
Condition	9kg ~ 18kg	15kg ~ 25kg	22kg ~ 36kg 125 ~ 145cm
Reference	70 ~ 105cm 1~4 years old	95 ~ 125cm 3~7 years old	6~11 years old
Using method	To install the child car seat on the vehicle seat with the seat belt and secure the child with baby belt.	To detach the baby belt, secure the child with the vehicle seat belt. The shoulder belt positioner should be used to fit the child's shoulder.	To detach the backrest and use the booster seat only. The shoulder belt positioner should be used to fit the child's shoulder.
Reference page	13	21	28



### DANGER

- The left mentioned applicable age and height are for reference only. If the child fits for the applicable age and height but do not fulfill the weight conditions, please do not use this mode.

## Name of parts

Please check all components are available before use.

The simplified illustration here is for easy understanding for customers and there may be a bit difference from the actual product.

### Sales package

- Main body
- Head support
- Lumbar support (EG only)
- Instruction manual (this book)
- Cup holder

#### Head support

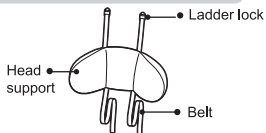

#### Lumbar support (EG only)

- Installation belts

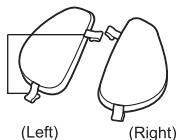

# Name of parts

Before use

## FRONT

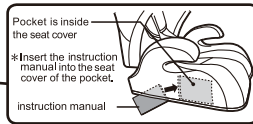
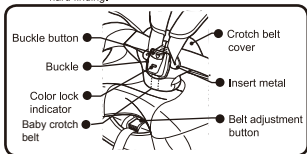
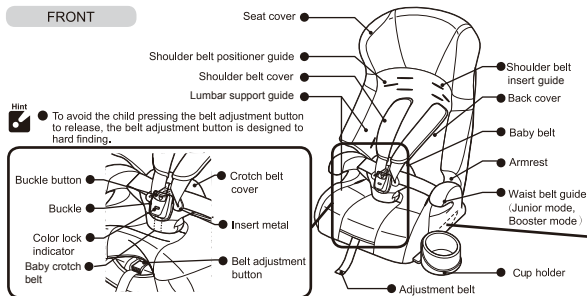

## BACK

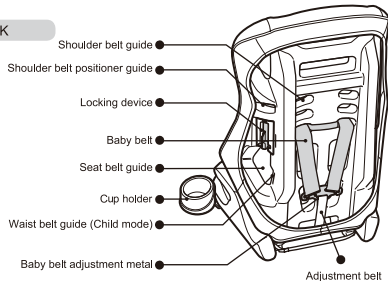

## Part names which are frequently used in this book

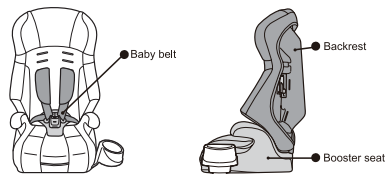

## Various types of vehicle safety belts and important notes for installation

Before use

Only suitable for use in the listed vehicles fitted with 3 point safety-belt, approved to CNS 3972 Regulation NO.16 or other equivalent standards.

### 2-point seat belt

Refers to the seat belt that secures the body in 2-points, one on each side of the waist.

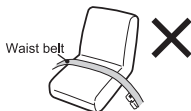

### 3-point seat belt

Refers to the seat belt that secures the body in 3-points, including left and right of the waist and either side of the shoulders.

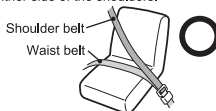

### DANGER

- Make sure to install the child car seat onto vehicle seats with 3-point safety belts.
- Do not install it onto seats with 2-point safety belts or it may not function as designed.

Type of seat belt	Characteristics	Child mode	Junior mode / Booster mode
ELR function (Emergency locking retractor)	Extendable normally but locked in sudden retraction.	Slowly pull out the seat belt to install the child car seat.	Slowly pull out the seat belt to install the child car seat.
AELR belt securing function	Belt that will be locked and cannot further extend when it is about to rewind after completely being pulled out.	After installation, pull out vehicle seat belt completely and use locking function.	It is danger if the seat belt is completely pulled out. Resume the seat belt first to disable the belt locking function.
Other	Not applicable to these seat belts	Not applicable ✕	Not applicable ✕

※ Should you have any enquiries about the types of seat belt, please contact the vehicle supplier.

# Inapplicable vehicle seats

## Inapplicable vehicle seats

Please do not install this product on unsuitable vehicle seat even though it has not been mentioned below.

Before use

- Vehicle seat without a seat belt.



- Vehicle seat with a 2-point seat belt.



- Seat facing rear or sideways against the driving direction.



- Seat equipped with a passive seat belt.

※ Passive seat belt refers to seat belt that automatically buckles itself upon sitting.



- Seat equipped with airbag. Seat equipped with only side air bag is applicable.



- The installation length of vehicle seat belt less than 32cm.  
※ The length between the extension point

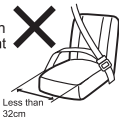

and the buckle of the vehicle seat belt.

- Seat of the sitting depth is less than 40cm.

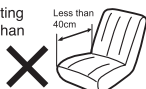

- Bucket seat with a hollow seat surface.



- Seat with a mounted middle portion which cannot secure the child car seat.



- Vehicle seat with seat belt extending from the center part, seat belt is extending from the middle of the seat where is located in the front of seat belt guide.



(1) According to regulatory requirements of Transportation and communications in Tai Wan, childer protective device is not permitted to fix in the vehicle seat equipped with airbag.

## For safe use of the child car seat

Before use

### ⚠ DANGER

The following misuses may cause the child car seat to malfunction and lead to danger.

- Do not seat a child who does not satisfy the applicable conditions, or install on a seat which is inapplicable.



- Never use the child car seat which cannot be secured as stated in this user guide. Please install the child car seat to the other vehicle seats.



- Do not install wrongly. Please install correctly according to user guide or indication stickers on the product.



- Always fix the child car seat with the vehicle seat belt when installing onto the vehicle. Never use a rope, string or other than seat belt to fix it.



- Do not install the child car seat on a vehicle seat equipped with air bag. In case of collision, the exploded air bag will expose the child to major impact which is extremely dangerous. Seat equipped with side air-bag is applicable.



- Do not allow child to stand on the seat. Please make sure the crotch belt is properly installed. The baby belt is well fastened to the buckle and color indicator is shown in green.



- Make sure the seat belt is properly adjusted after the child is seated.



### ⚠ In case of emergency

- In case of emergency, such as accidents, press the button to release the baby belt from the belt buckle, and remove the child from the vehicle seat immediately.





# For safe use of the child car seat

## ⚠ WARNING

The following misuses may cause malfunction to the child car seat and lead to danger.













- Always keep the seat belt fitting tight. Any looseness may get caught around the child's neck and may become the cause of suffocation, or the child may have chance to fall off from the child car seat in accident. Please adjust the baby belt to suitable length. (Refer to P.19)
  - Do not install on a vehicle seat of where the seat belt is damaged.
    - Structural damage may happen to the product when it is knocked or made to fall from high level. In such case stop using it even if the knock is one-off and no physical damage is seen.
- Please contact local distributor or retailer in case the belt buckle is malfunction or repairing request.
  - Do not lift the child car seat when the child is seated.
- The buckle button may be pressed and release accidentally by the child. It is important to check periodically the baby belt is well fastened.
  - Make sure to use the shoulder belt positioner when using as junior mode and booster mode. Otherwise, the shoulder belt may be slipping off the shoulder and cause danger.
- Do not use the baby belt if any damage is found. Please contact local distributor and retailer for an enquiry.
  - Adjust the shoulder belt positioner to be the same height as the child's shoulder so that the vehicle seat belt fits the child's body. (Please refer to P.27,29)
  - When installing on vehicle seat with particular safety car seat retracting function, disable the function first. Otherwise the seat belt may exert pressure on the child's chest. (Refer to P.5)
  - Do not leave your child in the vehicle unattended. In hot days the cabin temperature may rise and endanger the child to heat stroke or dehydration. It may also become the cause of accident. An adult should accompany all the time.
- Do not install the child car seat on the front seat if the gearshift or handbrake affects smooth operation.
  - ※ Please see note (2)
- Do not install on a front seat in a 2-door or 3-door vehicle in case it may obstruct passengers from getting out the vehicle in emergency.
  - ※ Please see note (2)
- Always fix the child car seat with the seat belt even when it is not in use. Otherwise it may fall off during sudden brakes and may cause disturbance to the driver.

(2) According to regulatory requirements of Transportation and Communications in Tai Wan, childer protective device is not permitted to fix in the front seat (auxiliary seat) position.

## For safe use of the child car seat

Before use

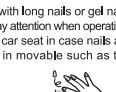
### ⚠ CAUTION

- Exposing the child car seat to direct sunlight will cause the insert metal or other parts to get excessively hot. Always touch and check all parts before seating your child.  

- Do not adjust the child car seat while driving. Make sure the child passenger do not play with the child car seat.  

- The backrest cannot be used alone.  

- Do not use the child car seat as a normal chair. It may have chance to tip over or fall off.  

- Make sure the child car seat is not jammed in between the vehicle doors or other movable parts.  

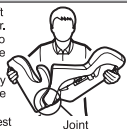
- Do not modify the child car seat or handle it in ways not described in this user guide.  

- Do not put a piece of cushion in between the vehicle seat and the child car seat.  

- Do not use the child car seat with the seat cover and other sewn parts or the urethane and other cushioning removed. Also do not replace these parts with parts not specifically authorized by Combi for this product. (This may negatively affect safety performance in the event of a collision.)  

- Do not expose the child car seat to windy or rainy environment.  

- Do not leave things unsecured in the vehicle. Things may fall off onto the child when the vehicle is in motion.  

- Do not lift and carry the child car seat with the baby belt.  

- Parents with long nails or gel nails should pay attention when operating the child car seat in case nails are jammed in movable such as the buckle.  

# Assembly method

The backrest and the booster seat are detached in the sales package. Please attach the backrest to the booster seat before using as child mode (P.13) and junior mode (P.21).

**CAUTION**

- Assemble the product on a flat and preferably soft surface to avoid scratching the product or the floor.
- Be careful not to pinch the fingers of people who assemble and people around when assembling the child car seat.
- To hold the child car seat as illustrated and pay attention not to let fingers get caught between the joint.
- Beware not to trap the baby belt between the backrest and the booster seat.



Joint

## To attach the backrest

- 1** Make sure the baby belt is not twisted and lay the backrest and booster seat down on the floor as illustrated. Set the baby belt properly.

\* Fasten the buckle when use in child mode.



- Hint** Make sure baby belt is not twisted before assembling the product.

- 2** Pull up the baby belt and check that the left and right buttons on the belt end are located above the baby belt insert outlets.

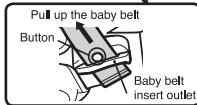

**WARNING**

- Do not use the product when the baby belt buttons are located below the insert outlets.



Button Baby belt insert outlet

\* Please follow the reverse steps to attach the backrest.

- 3**
- ① Check the baby belt on the rear side of backrest passes under the joint and adjust the fixing claw of backrest to the joint on the seating face.
  - ② Raise the backrest slowly until the fixing claw of backrest surely bridges the joint of seating face.
- \* For EG type, attach the lumber support attachment belt (lower) (page 11).

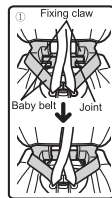

**CAUTION**

- Be sure to check the baby belt on the rear side of backrest passes under the joint.



The baby belt passes over joint.

**CAUTION**

Check the below before using the product.  
Otherwise the product may not function as designed and cause danger to child.

- Make sure the baby belt is not routing along the outer side of the armrest when using as child mode.
- Make sure the baby belt is not trapped in between the backrest and booster seat.

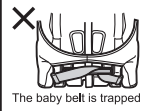

The baby belt is trapped

**WARNING**

- Before having your baby sit down, check the backrest is surely attached to the seating face.
- Check both of right and left fixing claws of backrest surely bridge the joint of seating face.



Removed the unilateral fixing claw.



## Assembly method

### Installing and using the cup holder

Cup holder can be attached to the left or right side of the car seat.

#### **⚠ WARNING**

- Do not put hot drinks into the cup holder.
- Do not install the child seat on the front seat in case the child seat together with the cup holder affects operation of handbrake and gear shift.

### Installing the cup holder

- ① Turn the booster seat base to upside down.
- ② Push the claws of the cup holder firmly into the mounting hole of the surface bottom of the seat base.
- ③ Try to pull out the cup holder to check if it is secured.

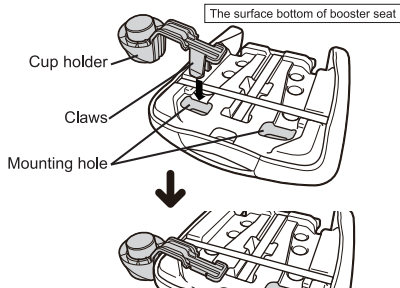

### Detaching the cup holder

- ① Remove the rubber band from the surface bottom of booster seat, and turn the seat cover to the front.
- ② Hold the two fixing claws inside to remove the cup holder from the mounting holes.
- ③ Pull out the cup holder from the surface bottom of booster seat.

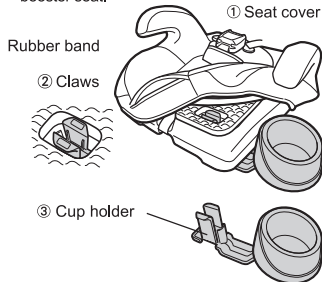

#### **⚠ CAUTION**

- Set the cup holder to the side away from the vehicle door in case it gets jammed in between the door and the car seat.
- Pay attention and prevent child from leaning its body to the cup holder. Otherwise damage may be caused to the cup holder.
- Some cups or drinks may not fit to the cup holder, make sure the cup holder can hold the cup or drink before use.

# Assembly method

Installation attach and use the head and lumbar support (EG only)

Head support and lumbar support can only be used for child mode of 9-15kg(excluding 15kg). Please apply according to the body size of baby.

## ⚠ CAUTION

- Do not place the removed head support or lumbar support inside vehicle cabin. During sudden brake, head support and lumbar support may roll over and affect driving.
- Do not hold on the head support or lumbar support when moving the child car seat. Otherwise the child car seat may fall off by accident and be damaged.
- Follow the instructions mentioned in the user guide to use the head support and lumbar support.

Installation attach the head support

- 1 Pull the belt on the head support through the shoulder belt insert outlets.
- 2 Flip the ladder belt over the backrest to the rear side of seat.

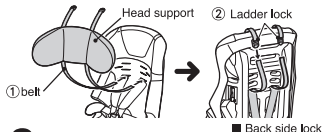

- 2 Fasten the belt onto the ladder.

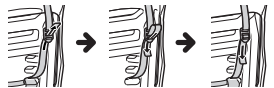

To detach the head support

\* Please follow the reverse steps to detach the head support.

Installation lumbar support

- 1 Check front, rear, right, and left sides of lumbar support and insert the lumbar support attachment belt (upper) (lower) in the lumbar support attachment hole (upper) (lower) of backrest.

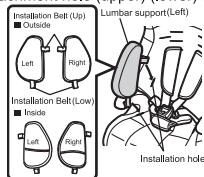

- After the attachment is finished, check the following to ensure the attachment of lumbar support.
  - To use the product in child mode, the baby body belt should pass the back side of lumbar support attachment belt (lower).

Baby Waist Belt

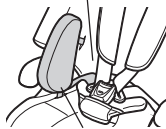

Installation Belt (Low)

\* Follow the reverse steps to detach the lumbar support.

Dismantle lumbar support 12

## Using as Child Mode (9-18kg)

### Preparation

Weight condition	9-18kg
Height reference	70-105cm
Age reference	1-4 years old
Using method	To secure the child car seat with the vehicle seat belt, and to secure the child with baby belt.



**Hint** Junior mode (P.21) and booster mode (P.28) can be used for child who is above 15kg.

### Adjusting shoulder belt to fit the child

To select the proper shoulder belt insert outlet according to the child's shoulder height.

To select the appropriate shoulder belt insert outlet, seat the child and select the appropriate shoulder belt insert outlet.



#### WARNING

- To use the pair of shoulder belt insert outlet just above the child's shoulder.
- Make sure left and right shoulder belt insert outlet to the seat is in the same level.

To use the pair of shoulder belt insert outlet just above the shoulder.

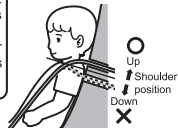

\* The crotch belt cannot be adjusted. Please adjust the shoulder belt.

## Using as Child Mode (9-18kg)

Adjust the shoulder belt according to the child's shoulder height.

### 1 Pull out baby belt.

- ① While pressing down the baby belt adjustment button (under the seat cushion)
- ② Grab the baby belt of both sides and pull them out until the end.  
\* Pull the baby belt to adjust, not the shoulder belt cover.



- To avoid the child pressing the belt adjustment button to release, the belt adjustment button is designed to hard finding.
- When pushing the belt adjustment button, please make sure to press on the "PUSH" mark.
- If the baby belt adjustment button is secured tightly, pull the baby belts towards at the same time when pressing on the button.

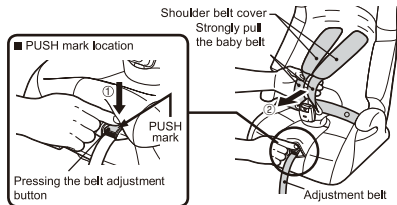

### 2 To detach the baby belt.

- ① Release baby belt from baby belt adjustment metal.
- ② Pull baby belt out from the shoulder belt cover to the front.  
\* You are not able to release the baby belt by pulling the shoulder belt cover, pull the baby belt.

Shoulder belt cover

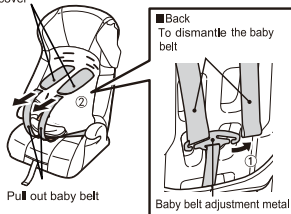

### 3 To change the position of the shoulder belt cover.

- ① Pull out both the left and right shoulder belt covers from the back.  
※ If it is hard to pull the shoulder belt cover out, push the base of the shoulder belt cover into the shoulder belt slot from the front of the seat, and then pull it out from the back of the main body.  
※ The shoulder belt cover in left and right is connected to the back of body by a connecting belt.
- ② Insert the shoulder belt covers back to the seat through appropriate shoulder belt insert outlets.  
※ Please refer to P. 13 "Baby adjusting shoulder belt to fit the child."

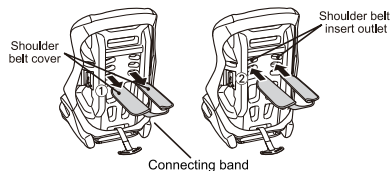

## Using as Child Mode (9-18kg)

### 4 Attach the baby belt

- ① Make sure the baby belt is not twisted and put it back into the shoulder belt covers.
- ② Pull the baby belt out at the back of seat.
- ③ Attach the baby belt's back to the baby belt adjustment metal.

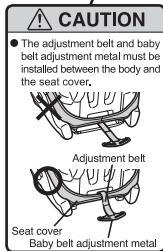
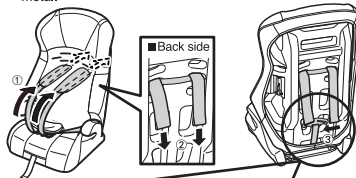

### Caution during installation

This section describes the caution during installation and the installation methods.

Our child car seat may not be able to install on particular seat with extra-ordinary seat shape. Please refer to Page 6.

### **! DANGER**

- Unsecured child car seat may not function as designed and may cause to danger. In such case, try to install to other seats.
- Always fix the child car seat with vehicle seat belt during installation.
- Do not install the child car seat onto the vehicle seat equipped with an air bag. In case of collision, the exploded air bag will expose the child to major impact which is extremely dangerous.
- \* Only install the child car seat to vehicle seat with a side air bag is acceptable.

### **! WARNING**

- Do not install on a vehicle seat of where the seat belt is damaged.
- Always secure a child car seat with vehicle seat belt inside the vehicle.
- Do not install the child car seat if the gearshift or hand brake which affects smooth operation.
- Do not install on the front seat of a 2-door or 3-door vehicle in case it may obstruct passengers from getting out the vehicle in emergency.

### Preparation before installation

- 1 Park the vehicle on flat ground where both left and right door can be opened completely.



- 2 Slide front seat forward and recline the backrest to the front for easier installation.





## Using as Child Mode (9-18kg)



In case of child mode, if the slide seat function is available, the child car seat can be installed firmly.

- 1 Slide seat to the back before installation as child mode.
- 2 Slide the seat forward after installation.



### Preparation of the vehicle seat

1

Adjust the vehicle seat to better secure the child car seat.

- 1 Remove the headrest of the vehicle seat if it is detachable.
- 2 Lower the seat belt if it is adjustable.
- 3 Place the child car seat on the vehicle seat (forward facing).

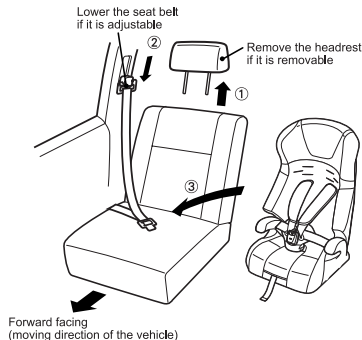

2

Adjusting the vehicle seat backrest to fit the child car seat can make the installation more secured.

- Adjust the angle of backrest of vehicle seat if it is an adjustable type so that it fits the main body of child car seat.

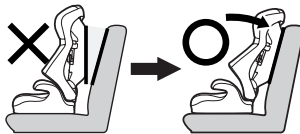

### WARNING

- Please adjust the angle of the vehicle seat if it has a reclining function. Set the child car seat with its backrest around 15 degree in line with the vehicle seat backrest.
- \* Please use the angle checker on the back cover to confirm the angle.
- It is dangerous to leave too much space between the child car seat and vehicle seat after installation.

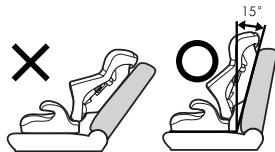

# Using as Child Mode (9-18kg)

Using as child mode

## Installation to the car

### 1 Secure the vehicle seat belt

- 1 Pull out the vehicle seat belt gradually. Make sure it is not twisted.
- 2 Pull the vehicle seat belt through the seat belt guide.
- 3 Please make sure the seat belt is not twisted.
- 4 Route the insert metal accordingly through the seat belt guide on the opposite side of the car seat.
- 5 Fasten the seat belt into the buckle until click sound.

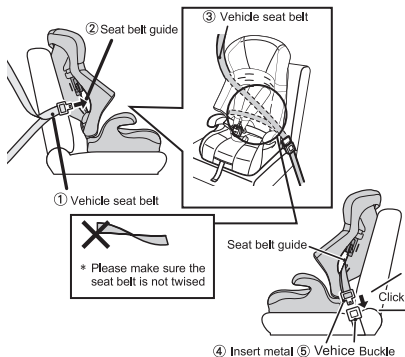

### 2 Secure the shoulder belt

- 1 Open the locking device which is on the opposite side of the buckle.
- 2 Clip the vehicle shoulder belt into the locking device and press it down to close.



- The locking device can be closed automatically. However, in order to firmly install the shoulder belt, please slightly press the locking device to close.

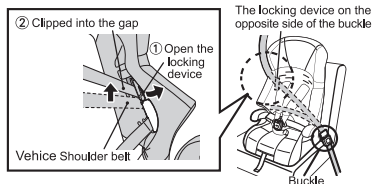

## WARNING

- Do not use the locking device on the same side of the buckle.
- Use only the locking device on the opposite side of the buckle.

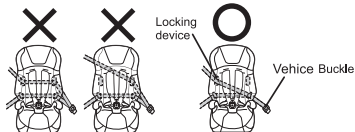

17

\* Please follow the reverse steps to remove the child car seat.

To remove the child car seat

## Using as Child Mode (9-18kg)

### Secured installation method

- 1** Tighten the seat belt as much as possible to secure the child car seat.
- 1 Kneel on the centre of the child car seat and add on body weight onto the vehicle seat.
  - 2 Pull the seat belt (shoulder belt) on the vehicle seat belt buckle up hard and tighten the vehicle seat belt (waist belt).
  - 3 Pull the vehicle shoulder belt (with another hand) of the lock structure part hard in the direction of the arrow to tighten it.
- Hint**
- Please repeat step ② and ③ while adding your own weight on the child car seat.

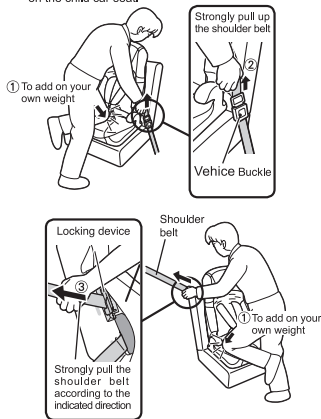

### Check method after installation

Check the followings after each installation.

- 1 There is no gap between the vehicle seat and child car seat.
- 2 Insert metal is fastened to buckle firmly.
- 3 There should be no loose, sag or twist in the vehicle seat belt.
- 4 Check the belt end on the buckle is not loose. (Please refer to the warning on P.19)
- 5 Seat belt (vehicle waist belt) is passing through the left and right belt guide properly.
- 6 The vehicle shoulder belt is passing through the locking device on the opposite side of the buckle and locked.
- 7 Hold the side part and shake it back and forth. The seat surface cannot move greatly.

\* Due to the design of the child car seat, the seat may move up and down during use but it is no problem to use.

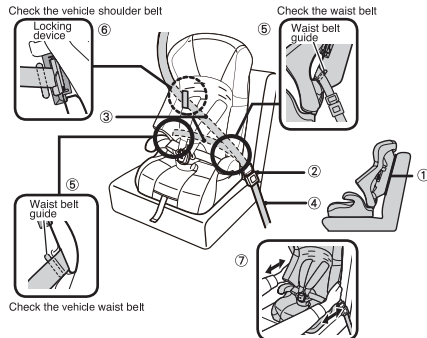

## Using as Child Mode (9-18kg)

Please contact local distributor for any inquiries.

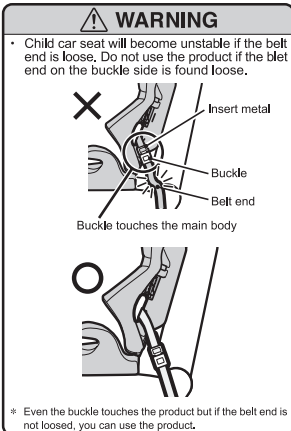

Check and re-install once again the steps stated on P.16 ~ 18 in case child car seat is not secured. Install on other seats if the child car seat still fails to secure. Otherwise the child car seat may not function properly as designed and may become cause of danger.

### Seating the child

Choose appropriate shoulder belt insert outlet before seating the child. (Please refer to P.13)



- 1** Pull out the baby belt.
- Press the baby belt adjustment button under the cover.
  - And pull the baby belt forward to loosen it, (see as below)
- \* Pull the baby belt to adjust, not the shoulder belt cover.

Hint



- To avoid the child pressing the belt adjustment button, the buckle button is designed to hard finding.
- Make sure to press on "PUSH" make while pressing on the adjustment button.
- If the belt adjustment button is secured too tight, pull the baby belt toward at the same time when pressing on the button.

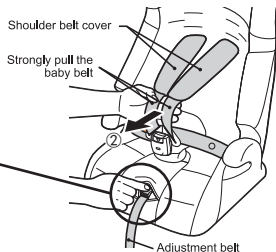
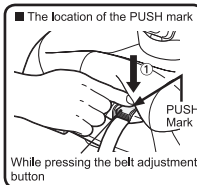

To lengthen the baby belt (while unseating the child)

## Using as Child Mode (9-18kg)

### Seating the child

- 2** To release the insert metal.
- 1 Press the buckle button.
  - 2 Release the insert metal.



- 3** Seating the child.
- 1 Seat child inside and let child's arms go through the baby belt.
  - 2 Match both insert metals together and fasten it into buckle until it clicks into place.

Make sure the baby belt is not twisted.

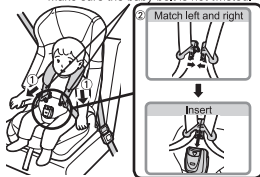

- To avoid child pressing the buckle button to release, the buckle button is designed to hard pressing.

- 4** Make sure the colored lock indicator turns to green.

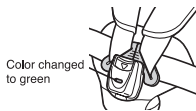

### WARNING

- Make sure the buckle is secured to avoid child from falling off seat accidentally during accident, or getting caught by belt on its neck causing suffocation.

- 5** To shorten the baby belt
- 1 Always pull down the waist belt to hold the pelvis position.
  - 2 The shoulder belt should be placed on the centre part of the child's shoulder.
  - 3 Pull the adjustment belt forward and adjust the two baby belts to appropriate length.

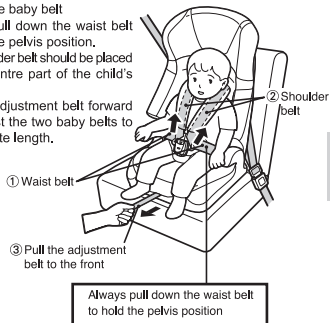

- Adjustment should neither be too tight nor too loose.
- Please make sure there's palm's space between the body and the seat belt.
- Please refer to P.19, "To lengthen the baby belt" when you want to loosen the baby belt.

### WARNING

- Be sure to adjust the length of the belt to fix the child. Otherwise child may fall off from child car seat during accident.
- The loosen baby belt may tangle the child's neck to suffocation.



## Using as Junior Mode (15-25kg)

### Preparation

Weight condition	15-25kg
Height reference	95-125cm
Age reference	3-7 years old
Using method	Detach the baby belt, to secure the child with the vehicle seat belt. Shoulder belt positioner should be used to fit the child's shoulder.



### DANGER

- Make sure to install on a seat equipped with 3-point seat belt. Do not install with a 2-point seat belt. Otherwise the child car seat may not function properly as designed and may cause of danger.
- Make sure to secure the child car seat with the seat belt even when it is empty. Otherwise it may become a potential danger in case of sudden brake etc.

### WARNING

- The shoulder belt positioner must be used or the shoulder belt may slip off the shoulder and cause danger.
- Disable the securing function of seat belt if there is any retracting function on the seat. Otherwise it may exert excessive pressure on child's chest. (Refer to P.5 for details.)
- Always keeps the seat belt is tight fitted. Any looseness may cause the child be tangled to the neck that may cause of suffocation.
- Do not install on a seat of which the seat belt is damaged.

### Switching to Junior mode

Please detach the baby belt and buckle if it was used as child mode (P.13).

### CAUTION

Please remove the child car seat from the vehicle seat before changing the mode.

### To detach the baby belt

- 1 Pull out the baby belt.
  - ① Match both insert metals together and fasten into the buckle until a "Click" sound is heard.
  - ② Press on the belt adjustment button "PUSH".
  - ③ Grab both left and right baby belt and pull them forward to loosen.

\* Pull the baby belt to adjust, not the shoulder belt cover.



Hint

- To avoid the child pressing the belt adjustment button, it is designed to hard finding.
- When pushing the belt adjustment button, please make sure to press on the "PUSH" mark.
- If the baby belt adjustment button is secured tightly, pull the baby belts towards at the same when pressing on the button.

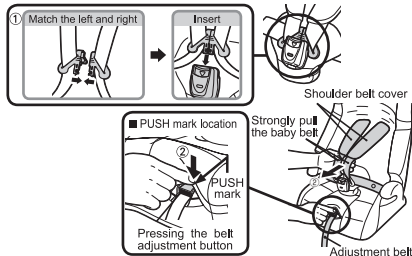

## Using as Junior Mode (15-25kg)

### 2 To detach the baby belt.

- ① Remove the left and right baby belt from the belt adjustment metal at the back of main body.
- ② Remove the shoulder belts from the shoulder belt covers.
  - \* Pull on the baby belts but not the belt covers to remove the baby belt.

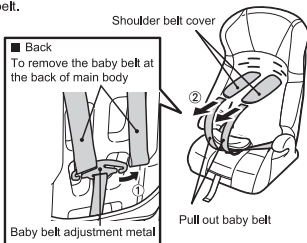

- ③ Remove the left and right baby belt from the insert metal.
- ④ Pull the baby belt through the openings from the back of the main body.

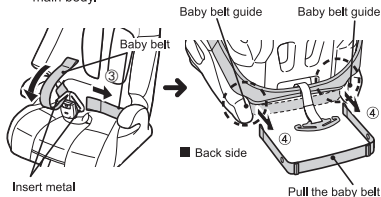

Hint Make sure belts are not twisted or reversed before pulling out the baby belt.

### 3 Detach the shoulder belt cover

- Pull out both the left and right shoulder belt covers from the back.  
 ※ The shoulder belt cover in left and right is connected to the back of body by a connecting belt.

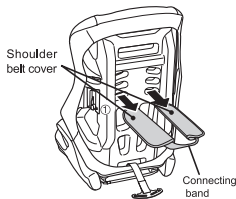

- When the shoulder belt cover cannot be pulled out, please press the front end of the belt that has passed through the shoulder hole before the body is pulled out from the body.
- Please refer to P.31 for "To attach the baby belt".
- Please refer to P.23 for "To attach the buckle".

## Using as Junior Mode (15-25kg)

### To detach the baby crotch belt

Main body is not in stable condition. Remove booster seat from backrest before this step. (P.10)

- 1 Pull out the belt stopper at the bottom of the seat base a little bit, place it vertical and insert the whole belt stopper through the opening to the surface of seat base.
- 2 Pull out the baby crotch belt from the surface of seat base.



- Hint
- Press onto the crotch belt from the top of seat base and the belt stopper can be removed more easily.

### WARNING

- Afer installing the belt stopper, please pull on the crotch belt to ensure it is secured.

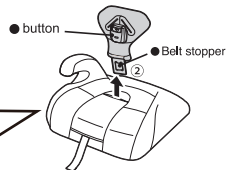
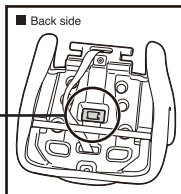
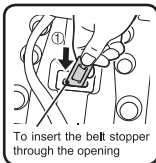

- \* Place the belt stopper vertically and insert it through the opening on the booster seat for attaching.

### CAUTION

Please detach the backrest

- Before detaching the baby crotch belt or main body will become unstable.
- Please handle the detached baby belt, buckle and not to lose them.

Baby belt



Shoulder belt cover



Baby belt

Crotch belt

Insert metal

Lumbar support

- Buckle
- Crotch belt cover



(EG only)



- Hint
- In order not to lose the insert metal, please fasten it into the buckle.
  - Please refer to P.21 for "Detaching the baby belt".

\* To follow the reverse steps to attach the crotch belt.

To attach the crotch belt



## Using as Junior Mode (15-25kg)

### To store the baby belt adjustment metal

To store the baby belt adjustment metal Detach the backrest, remove seat cover and cushion first and then store the baby belt adjustment metal.

\* The baby belt adjustment metal should be stored under the cushion.

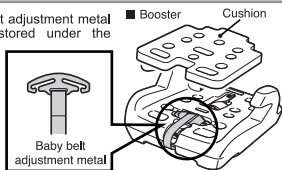

- 2** ① Press the baby belt adjustment button.  
② Pull the baby belt adjustment metal to the end.

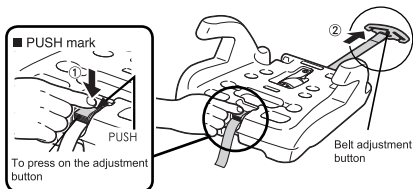

Make sure to press [PUSH] button to adjust safety belt.

- 1** The baby belt adjustment metal should be passing through the adjustment belt insert outlet located at the joint of backrest and the booster seat.

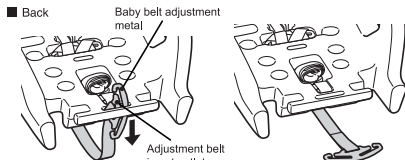

**Hint** ■ Please refer to P.30 for to attach the baby belt adjustment metal.

- 3** To store the baby belt adjustment metal.

- ① The baby belt adjustment metal should be placed in front of the booster seat.  
② Rolling the adjustment belt evenly on the baby belt adjustment metal.  
③ Put into the storage part.

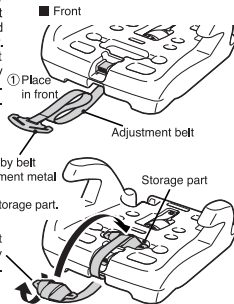

## Using as Junior Mode (15-25kg)

### Preparation of the shoulder belt positioner

Preparation of shoulder belt positioner  
Detach the backrest (P.10) and remove seat cover and cushion (P.33) and take out the shoulder belt positioner.

- \* The shoulder belt positioner should be stored under the cushion of booster seat.

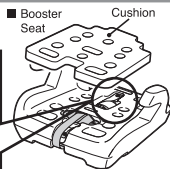
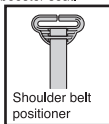

Hint

- Please refer to P.30 to store the shoulder belt positioner.

- 1 Take the shoulder belt positioner out from the storage.

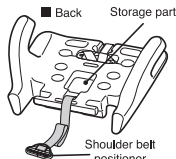

- 2 Attach the seat cover back to the booster seat. (Refer to P.33)

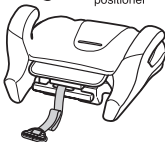

### Please attach the backrest before moving on below steps

- 3 Pull the shoulder belt positioner between the seat cover and the body.

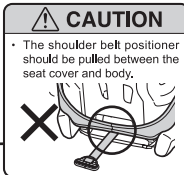
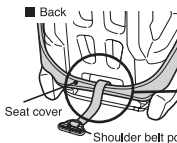

- 4 Attach the shoulder belt positioner.
  - ① The shoulder belt positioner should be pulled through the insert outlet located on the opposite/side of the buckle.
  - ② Pull the shoulder belt to the front.

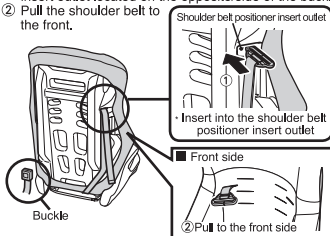

### WARNING

- Please make sure the shoulder belt positioner is to be pulled through the shoulder belt positioner insert outlet and NOT the shoulder belt insert outlet.

## Using as Junior Mode (15-25kg)

### Installing to the car

#### WARNING

- Adjust the angle of the vehicle seat backrest if it has a reclining function. Set the child car seat backrest that is around 15 degree in line with the vehicle seat backrest. If the child car seat installed on a reclined vehicle seat may fail to protect the child from accident.

\* Please use the angle checker printed on the cover printed on this user guide to check the angle.



- Remove the headrest of the vehicle seat if it is detachable.
- Adjust the vehicle seat belt to its highest position.



- Place the child car seat on the vehicle seat and pull out the vehicle seat belt.

- Pull the vehicle seat belt through the shoulder belt positioner.
- Pull the vehicle waist belt through the waist belt guides under the left and right armrest.
- Fasten the buckle until "click" sound is heard.

- The shoulder belt should be pulled from the upper part of the backrest.

#### CAUTION

- Keep the child car seat assembled as illustration even when it is empty.

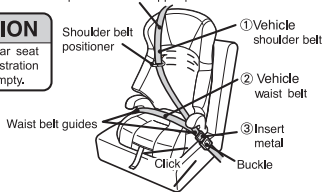

### Seating the child

Seat the child deeply into the child car seat.

#### WARNING

- The child car seat will become unstable if it is not fastened with the vehicle seat belt. Do not let the child go on and off the child car seat alone. The guardian should assist seating or unseating the child to the child car seat.
- Do not seat the child as illustrated. Otherwise the child car seat may not function as designed and become a danger.

Leaning or bending its body forward, Leaning its body extremely to the side, Sitting with its feet up on the seat base.



Release the buckle temporarily. Seat the child deep into the seat, pull out the seat belt as illustrated and fasten the buckle until a sound "Click" is heard.  
\* Always pull down the waist belt to child the pelvis position.

#### WARNING

- The child's arm at all times should not go underneath the waist belt.



#### CAUTION

- Be careful of the joint between the backrest and the booster seat in case child's clothes get jammed.

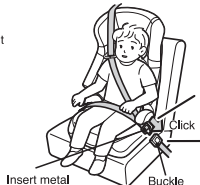

## Using as Junior Mode (15-25kg)

### To adjust the shoulder belt positioner

Seat the child deep into the child car seat.

Then adjust the shoulder belt positioner to be the same height of child's shoulder. The shoulder belt positioner is stored underneath the cushion of the booster seat.

#### The correct position of shoulder belt positioner

Adjust the shoulder belt positioner to be the same height of the child's shoulder as illustrated so that the vehicle seat belt fits the child, the shoulder belt positioner may be close to the child's shoulder.

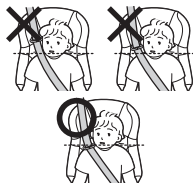

### WARNING

The vehicle shoulder belt positioner should be adjusted to let the shoulder belt secured the child. Please adjust the height according to the child's growth.



#### To extend



#### To shorten



#### Attachment of belt

If the belt of shoulder belt positioner is detached, please attach the belt as illustrated.



### Check after installation

Check the followings after seating the child and fastening the seat belt.

- ① Tight fit the child car seat to the vehicle seat backrest.
- ② The shoulder belt is passing from the upper part of the backrest.
- ③ The shoulder belt is passing through the shoulder belt positioner, is not tangling child's neck, or too loose from child's shoulder.
- ④ Seat belt fits tightly with child, not twisted, and without any looseness.
- ⑤ Child's pelvis is secured with seat belt (waist belt).
- ⑥ Insert metal is fastened to buckle firmly.
- ⑦ Vehicle shoulder belt and vehicle waist belt are passing through waist belt guides.

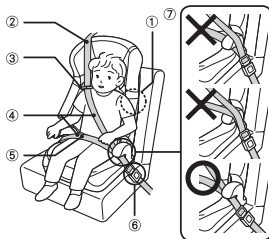

### WARNING

- Check and re-install once again the steps stated on P.26 in case child car seat is not secured. Install on other seats if the child car seat still fails to secure. Otherwise the child car seat may not function properly as designed and may become cause of danger.
- Please use as booster mode instead if the child's head protrudes the headrest of the child car seat or it may not function as designed and lead to danger.

## Using as Booster Mode (22-36kg)

### Preparation

Weight condition	22 - 36kg
Height condition	125-145cm
Age reference	6-11 years old
Using method	Firstly detach the backrest and baby belt and set the vehicle seat belt. The shoulder belt positioner should be used.



### **!** DANGER

- Make sure to install on a seat equipped with 3-point seat belt. Do not install with a 2-point seat belt. Otherwise the child car seat may not function properly as designed and may cause danger.
- Make sure to secure the booster seat with the seat belt even when it is empty. Otherwise it may become a potential danger in case of sudden brake etc.

### **!** WARNING

- Disable the securing function of seat belt if there is any retracting function on the seat. Otherwise it may exert excessive pressure on child's chest. (Refer to P.5 for details.)
- Always keeps the seat belt tightly fitted. Any looseness may cause the child be tangled to the neck that may cause of suffocation.
- Do not install on a seat of which the seat belt is damaged.
- The shoulder belt positioner should be used or the seat belt may be loosened from the shoulder and cause danger.

### Switching to Booster mode

- Please refer to P.21-25 when converting from child mode.
- Please detach the shoulder belt positioner (P.30) from backrest (P.10) when converting from junior mode.

### **!** WARNING

- Set the backrest of the vehicle seat at the upright position in case it has a recline function. A child car seat installed on a reclined vehicle seat may fail to protect a child from accident or child may fall off the booster seat. The loosen seat belt may tangle to the child's neck causing suffocation.



### Installation to the car

- 1 Attach the headrest of the vehicle seat if it is detachable.
- 2 Lower the seat belt if it is adjustable vehicle.

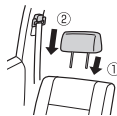

- 2 Place the booster seat on the vehicle seat, pull out vehicle seat belt.
  - 1 Pull the vehicle shoulder belt through the shoulder belt positioner.
  - 2 Pull the waist belt through the waist belt guides underneath the armrests.
  - 3 Fasten the buckle until "Click" sound.

- The headrest is attached.

Shoulder belt positioner ①

Waist belt guides ②

Insert metal

③

Click

Buckle

### **!** CAUTION

- Keep the booster seat installed as illustration even when it is empty.

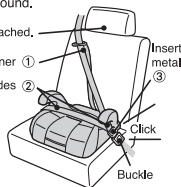

## Using as Booster Mode (22-36kg)

### Seating the child

Release the buckle temporarily.

Seat the child deep into the booster seat, pull out the vehicle seat belt.

- 1 Pull the waist belt through the waist belt guides underneath the armrests.
  - 2 Fasten the buckle until "Click" sound.
- \* Always pull down the waist belt to hold the pelvis position.

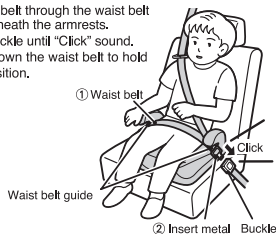

Using as booster mode



29

### To adjust the shoulder belt positioner

Seat the child deep into the booster seat and adjust the height of shoulder belt positioner to fit the child.

- \* The shoulder belt positioner is stored under the cushion of the booster seat.



#### The correct position of shoulder belt positioner

Adjust the shoulder belt positioner to be the same height of the child's shoulder as illustrated so that the vehicle seat belt fits the child.

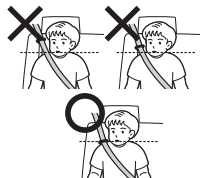

#### **WARNING**

- The vehicle shoulder belt positioner should be adjusted to let the shoulder belt secured the child. Please adjust the height according to the child's growth.

#### To extend



#### To shorten



#### Attachment of belt

If the belt of shoulder belt positioner is detached, please attach the belt as illustrated.



## Using as Booster Mode (22-36kg)

### Check after installation

Check the followings after seating the child and fastening the seat belt.

- ① Headrest of vehicle seat is attached.
  - ② The shoulder belt is passing through the shoulder belt positioner and is not tangling child's neck, or too loose from child's shoulder.
  - ③ Seat belt fits tightly with child, not twisted, and without any looseness.
  - ④ Seat belt (waist belt) is securing child's pelvis.
  - ⑤ Insert metal is fastened to buckle firmly.
  - ⑥ Vehicle shoulder belt and vehicle waist belt is passing through waist belt guides underneath the left and right armrests.
- \* Please contact local distributor for any inquiries.

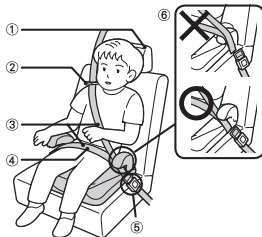

### WARNING

- Check and re-install once again the steps stated on P.28-29 in case booster seat is not secured, install on other seats if the booster seat still fails to secure. Otherwise the child car seat may not function properly as designed and may become cause of danger.

## Converting back to Child Mode

### To store the shoulder belt positioner

When using as child mode (P.13), the shoulder belt positioner is not used and store it under the cushion.

- 1 Please detach the shoulder belt positioner when using as junior mode.

■ Seat back

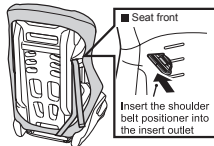

- Hint
- Please refer to P.25 "Preparation of shoulder belt positioner"

- 2 Detach the backrest (P.11) and remove seat cover and cushion. (P.33)

- ① Roll the shoulder belt positioner to the shoulder belt.
- ② Put into the storage part.

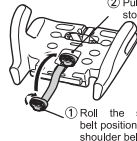

### To attach the baby belt adjustment metal

When switching from junior mode (P.21) or booster mode (P.28) to child mode (P.13), take out the baby belt adjustment metal stored at booster seat and then install it onto the bottom side of the booster seat.

- \* Main body is not in stable condition. Remove the booster seat from backrest before this step. (P.10)

- 1 Remove the seat cover and cushion from the booster seat (P.33), take out the baby belt adjustment metal, and then put the seat cover and cushion back.

- Hint
- Refer to P.24 for removing baby belt adjustment metal and the way to store it onto the booster seat.

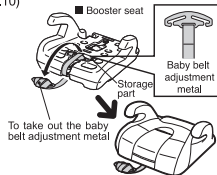

# Converting back to Child Mode

To attach the baby belt adjustment metal

- 2** Make sure the adjustment belt is not twisted.
- 1 Pull the adjustment belt in between the main body and the rubberband.
  - 2 Place the adjustment metal vertical and put it through the insert outlet.

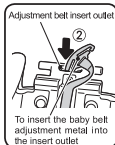

■ Back of booster

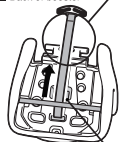

1 Pull the adjustment belt between rubberband and main body

To install the baby belt

When using in child mode (P.13) make sure to install the baby belt onto the backrest.  
\* Main body is not in stable condition. Remove booster from backrest before this step.

- 1** Attach shoulder belt covers to the shoulder belts.
- 1 From the back of the seat, put the shoulder belt covers through the correct pair of insert outlets to the front of seat.
  - 2 Pull the shoulder belt covers to the front.

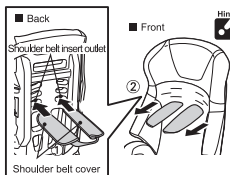

- 3** Attach baby belt.  
Make sure baby belt is not twisted, and

- 1 Put the baby belt through the left and right insert outlets located at the back of the backrest.
- 2 Pull the baby belt to the front until the buttons have gone through the insert outlets completely.

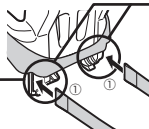
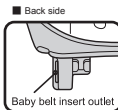

- 2** Check the direction of baby belt.  
Make sure belts are not twisted, and the protruded side is facing outside.

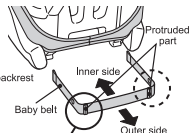

- 2** Pull out the baby belt to the front.





## Converting back to Child Mode

➔ To attach the buckle (P.23) and backrest (P.10) before moving on to next step.

- 4**
- ① Make sure baby belts are not twisted and pull the left and right baby belts through the insert metal respectively.
  - ② Make sure the baby belts are not twisted and attach the shoulder belt covers.
  - ③ Pull the shoulder belts through the insert outlets to the back.

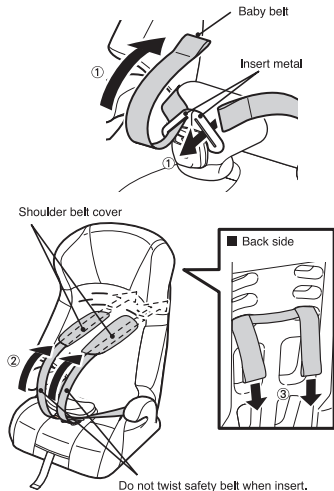

- 5**
- Attach both left and right baby belt to baby belt adjustment metal.
- ① The belt adjustment metal and adjustment belt should be pulled through the body and seat cover.
  - ② Attach the left and right baby belt to the baby belt adjustment metal.

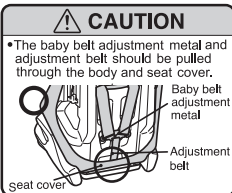
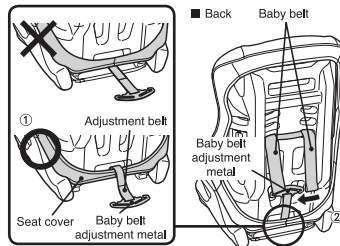

# Maintenance

## Head support, lumbar support (Only EG type)

Please refer to P.11 "To attach and use the head support".

## To detach the seat cover on the backrest

- 1 Remove the upper part of the seat cover from the backrest.
- 2 Remove the seat cover from the backrest.

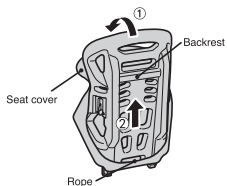

Hint

The rope part of the seat cover should be pulled through the backrest.

## To attach and detach the fabric parts

### To attach and detach the baby belt

Please refer to P.21 "To detach the baby belt".  
Please refer to P.31 "To attach the baby belt".

## To detach the seat cover on the seat part

Remove the backrest (P.10), detach the buckle (P.23) and then detach the seat cover.

- 1 Detach the rubberband (total 3 places) on the bottom of the seat.
- 2 Flip the front side of the seat cover.
- 3 Detach the pocket-like part.
- 4 Detach the seat cover from the armrest.

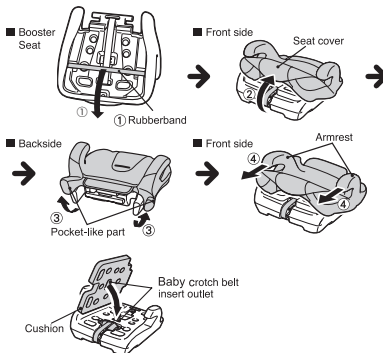

Hint

Match the cushion to the baby crotch belt insert outlet.

# Washing method / Storage

## Washing the seat cover

Follow the below instructions to wash the seat cushion.

- Follow the instructions noted on the washing label sewn onto the seat cover.
  - When using a washing machine, place the items in a laundry net. Failure to do so may result in fraying or other damage.
  - Use the gentle cycle of the washing machine with cold or lukewarm water, or wash by hand.
  - Do not use bleach.
  - Use a neutral detergent. Do not use detergent containing fluorescent brightener or bleach. This may cause chapped skin or a rash.
  - When using a horizontal washing machine (a washing machine with the drum facing horizontally or inclined), make sure the water level is sufficient.
  - Color fading may occur due to the nature of the product.
  - It is recommended to wash separately from other clothing and lightly colored items.
  - Rinse thoroughly, wring out lightly, and then arrange the shape and dry in the shade.
  - Do not iron.
  - Do not use a dryer or dry cleaning.
  - Please remove the urethane inside before washing the head support.
  - Please remove the inside of cotton before washing the lumbar support (EG type only).
- ※ Do not cleaning the head support ,lumbar support and seat of cotton.

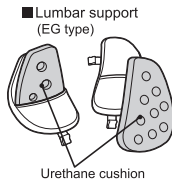
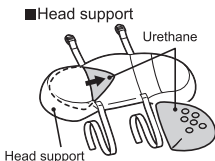

## Caring for the body, the baby belt

- Clean main body with a piece of damp cloth. For serious dirt, clean with diluted neutral detergent. After washing, dry the main body in shaded area.

### ⚠ WARNING

- Do not use undiluted detergent, gasoline or other organic solvents when cleaning. Otherwise it may cause damage to the main body or the baby belt.

## Storage

- Main Body: When the child car seat will not be in use for a period of time, uninstall it and store in shaded place clear from children.
- User Guide: Please read this user guide carefully and store it underneath the booster seat.

### Urethane

The dyestuff of seat cushion may transfer onto the urethane. However, it is no problem to use.

## How to dispose it

- Never use the product if once it has received a strong shock such as a car crush or drop of the product even if you cannot see any damage out side. When you dispose the product due to the above reason, remove the seat cover so that the product cannot be reused by somebody.

# Combi Corporation

幼童用座椅・學童用座椅

## Joytrip

### 使用說明書

- 為了您孩子的安全，請於使用前閱讀本使用說明書，在理解後，按照記載內容來正確使用。
- 閱讀本使用說明書後，請將說明書存放在座部墊子里側的口袋中。(參照P.4)



本產品為通過了 CNS 11497 基準的幼童保護裝置。

通用型: G1,2,3

適用體重: 9-36公斤

使用前

組裝方法  
安裝靠背的方法  
(請參考第10頁)

幼童用座椅模式

學童用座椅 (I) 模式

學童用座椅 (II) 模式

還原成幼童用座椅模式



洗滌方法及保養廢棄

## 本產品的安全使用

承蒙購買本公司產品幼童保護裝置，深表感謝。使用前請仔細閱讀本說明書，然後正確使用。

幼童保護裝置是在交通意外等情況發生時，以盡量減少損傷而設計的，但並不保證會令兒童毫無損傷。在使用幼童保護裝置時，大人也必須同行。

這裡提及的注意事項和使用條件等目的在於確保幼童能安全和正確地使用本幼童保護裝置，以發揮本幼童保護裝置的應有保護功能。[危險][警告][注意]等標籤，是以如果不遵守正確使用方法時，按照預料的危害或損害的迫切及大小程度進行區分的標籤，內容是非常重要的。請務必遵守。

標籤	標籤內容
 <b>危險</b>	如操作錯誤，會引致死亡或重大傷害。
 <b>警告</b>	如操作錯誤，會有可能引致死亡或重大傷害。
 <b>注意</b>	如操作錯誤，會有可能造成傷害，或組件損壞。
 <b>小提示</b>	有關保護裝置使用上建議參考的內容和有幫助的小提示。

使用前請詳細閱讀

# 目錄

## 使用前

### P1~P9

使用前	1
根據幼童的體重使用	3
各部品名稱	4
汽車安全帶的種類及安裝上的注意事項	5
不能安裝的汽車座席	6
本產品的安全使用	7-9

## 組裝方法

### P10~12

安裝靠背	10
杯托的安裝和使用方法	11
拆除杯托	11
使用及安裝護頭墊及護腰墊	12

## 使用幼童用座椅(9-18公斤)

### P13~20

使用前的準備	13
兒童肩帶的調節方法	13-15
安裝上的注意事項	15
安裝前準備	15
汽車座席的準備	16
安裝到汽車上	17
牢固安裝到車上的方法	18
安裝完成后的檢查	18
讓幼童乘坐	19-20

## 變更為學童用座椅(I)(15-25公斤) P21~27

使用前的準備	21
變更為學童用座椅(I)模式的方法	21

拆除兒童安全帶及釦子	21-23
收納安全帶調節金屬	24
準備肩帶導引	25
安裝到車上	26
讓兒童乘坐	26
肩帶導引的調節方法	27
完成安裝後的檢查	27

## 使用學童用座椅(II)(22-36公斤) P28~30

使用前的準備	28
模式變更方法	28
兒童乘坐前的準備	29
肩帶導引的調節方法	29
完成安裝後的檢查	30

## 還原至幼童用座椅 P30~32

收納肩帶導引	30
安裝安全帶調節金屬	30-31
安裝兒童安全帶	31-32

## 日常保養 P33~34



拆除(靠背)座墊	33
拆除座部的座墊	33
座墊的清洗方法	34
本體及安全帶的保養方法	34

## 保存方法 P34

保存方法	34
廢棄方法	34
角度調節器	背頁

## 根據幼童的體重使用

配合幼童的體重，本產品可作三種不同用法。

模式	幼童用座椅模式		學童用座椅(I)模式		學童用座椅(II)模式	
使用狀態						
條件	9~18 公斤		15~25 公斤		22~36 公斤	
參考	70~10 釐米 1歲至4歲		95~125 釐米 3歲至7歲		125~145 釐米 6歲至11歲	
使用方法	使用汽車安全帶將幼童保護裝置固定，用兒童安全帶緊扣兒童。		拆除兒童安全帶，用汽車安全帶直接緊扣兒童，並按兒童肩膀的高度使用肩帶導引。		拆除靠背，只使用座面，按兒童肩膀的高度使用肩帶導引。	
參考頁數	13		21		28	

### ⚠ 危險

以上所提及月齡以及身高只作參考。如幼童滿足上述的月齡及身高條件，但未能符合有關的體重條件，請不要以此模式使用。

使用前請詳細閱讀

## 各部品名稱

請在使用前確認各配件是否齊全。  
本說明書以簡單易明的目的來繪畫插圖，故與實際產品可能有異。

### 銷售包裝

- 主體
- 護頭墊
- 護腰墊 (只限EG型)
- 說明書 (本書)
- 杯托

#### 護頭墊

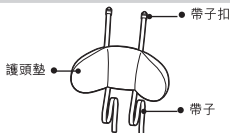

#### 護腰墊 (只限EG型)

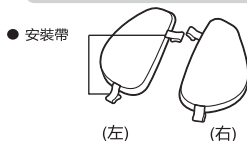

# 各部品名稱

使用前請詳細閱讀

## 正面

小提示



● 為避免幼童自行解扣，故將插扣按鈕的位置設計成比較難於發現的結構。

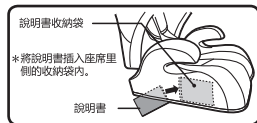
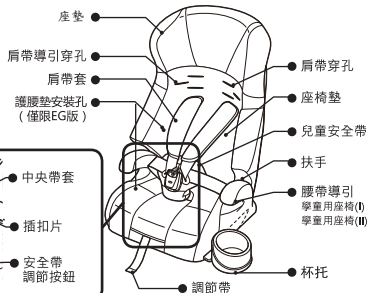
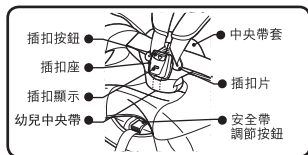

## 背部

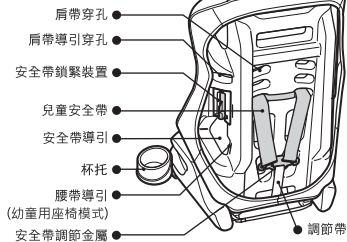

## 在本書經常使用的部件名稱





## 汽車安全帶的種類及安裝上的注意事項

本產品只適宜於已附有能通過CNS 3972制定的第十六條規定或其他相等標準的三點式/附設收緊裝置安全帶的汽車上。

### 2點式汽車安全帶

- 2點式安全帶是指如圖般以腰部左右 2 點固定乘客的安全帶。請勿安裝在設有2點式安全帶的汽車座席上。



### 3點式汽車安全帶

- 請安裝在設有 3 點式安全帶的汽車座席上。3 點式安全帶是指如圖以腰部左右和肩部共3點固定乘客的安全帶。



**危險**

- 請安裝在3點式安全帶的汽車座席上。
- 切勿安裝在2點式安全帶的汽車座席上。

安全帶的種類	特徵	幼童用座椅	學童用座椅(I)(II)
附ELR (緊急鎖定功能的回卷裝置)	一情況下可自由伸縮，在意外時會自動鎖定的安全帶。	安裝時，慢慢拉出汽車安全帶。	安裝時，慢慢拉出汽車安全帶。
附AELR裝置	拉出安全帶途中時，一旦停下就會被鎖定，此時不能接著再拉出安全帶。	在安裝完成後將汽車安全帶全部拉出，並依靠鎖緊裝置來固定。	如將安全帶全部拉出是非常危險的。撤回安全帶讓固定功能取消。
其他	不適用於上記得座席安全帶。	不可以使用。 ❌	不可以使用。 ❌

※ 如對安全帶的種類有任何疑問，請聯絡汽車供應商。

使用前請詳細閱讀

## 不能安裝的汽車座席

使用前請詳細閱讀

### 不能安裝的汽車座席

即使以下所示的汽車座席中沒有提及，若不能妥當地固定此幼童保護裝置的場合下，請勿使用本產品。

- 沒有安全帶的座席



- 2點式安全帶的座席



- 側向或後向的座席



- 已裝置自動式安全帶的座席

※自動式安全帶即關上門後會自動扣上的自動型安全帶。



- 設有安全氣囊的座席。只設有側氣囊的座席則可以安裝。



- 車輛安全帶的安裝幅度在32釐米以下的座席，車輛安全帶與座席末端重疊處至帶扣之間的長度。



- 座深在40厘米以下的座席。

少於40厘米



- 形狀極端的桶型座席(中央部分深陷的座席)。



- 座面極度凹凸不平，令安裝不穩的座席。



- 安全帶從座席中間伸出的汽車座席。汽車安全帶伸出點於幼童保護裝置的安全帶導引較前的座席。



## 本產品的安全使用

### ⚠ 危險

以下的錯誤操作，非但不能發揮幼童保護裝置應有功能，更會引致危險。

- 請勿讓不符合使用條件的幼童乘坐本幼童保護裝置，或是安裝在不合適的汽車座席上。



- 假如無法按照說明書的指示穩固地安裝本幼童保護裝置時，請勿使用。



- 請依照說明書以及主體的說明貼紙的指示正確地安裝。



- 安裝幼童保護裝置於車內時，必須使用汽車安全帶來作固定。不可用繩子等安全帶以外的東西代為固定。



- 請勿安裝於設有氣囊的車座上。若意外時彈出的氣囊會造成重大衝擊，對幼童構成危險。請安裝在沒有氣囊的座席上。只設有側氣囊的座席可以進行安裝。



- 請勿讓幼童在幼童保護裝置上站立，蹲身或跪坐在座面上。幼童乘坐幼童保護裝置時，請確認中央帶和兒童安全帶是否安裝正確，左右兩邊的插扣片是否完全地插入帶扣，並且顯示器的顯示已變成綠色。



- 讓幼童坐下後請確認安全帶已正確地調節好。



### ⚠ 緊急逃脫

- 有緊急事故時，家長請按下帶扣的按鈕，鬆開兒童安全帶，然後迅速抱兒童逃出車外。



(1) 根據臺灣交通部法規要求，幼童保護裝置不得安裝於設有氣囊的汽車座席上。

使用前請詳細閱讀

# 本產品的安全使用

使用前請詳細閱讀

## 警告

以下的錯誤操作，非但不能發揮本產品應有功能，更會引致危險。

- 請勿在安全帶鬆弛的狀態下使用，以免意外時幼童跌出，或令安全帶纏脖子引至窒息。請調節安全帶至合適的長度。(請參考 P.19)



- 若發現汽車安全帶損壞時，請不要在該座席上進行安裝。



- 請調節肩帶導引至適合的高度。(請參考第27,29頁)

- 假如安裝在前座影響變速器或手煞車等操作時，請改為安裝在後座上。

※ 請見備註 (2)



- 如安全帶扣不能牢固或有堵塞物引致阻礙時，必須安排維修。有關維修安排請向經銷商查詢。



- 幼童保護裝置經受強烈撞擊或從高處墮下會因撞擊後損害而失去保護功能，即使表面沒有破損也絕對不能再使用。請更換幼童保護裝置。



- 假如座席上具備座椅固定功能，請先將此功能解除，否則幼童可能因過度約束感到胸部受壓。(請參考第5頁)



- 在2門或3門汽車上安裝時，假如後座有乘客，則請勿將座椅安裝在輔手席上，以免意外時座椅阻礙乘客逃出。

※ 請見備註 (2)



- 幼童也許有按壓安全帶扣的可能性，所以要隨時留意並確認插入的扣片沒有脫離安全帶扣。



- 在幼童乘坐的狀態下請勿搬運幼童保護裝置。



- 請勿讓幼童單獨留在車上。陽光猛烈時，車箱內溫度升高有可能令幼童出現脫水症狀，又或是引致其他意外。在任何情況下，幼童都應該在成年人陪同下使用本幼童保護裝置。

- 兒童安全帶如果有損壞的情形時，一定要更換新的安全帶。有關維修安排請向經銷商查詢。



- 必須使用肩帶導引否則在意外時，肩帶會滑落而引致危險。

















- 即使沒有幼童乘坐，也請以安全帶固定幼童保護裝置，以免剎車等時候，座椅在車箱內滾動而影響駕駛。



## 本產品的安全使用

### ⚠ 注意

- 陽光直接照射，可能使幼童保護裝置或插扣片等變熱。所以讓幼童坐下前，請先觸摸各配件，確認後才開始使用，以免受傷。  

- 請勿在駕駛時調節幼童保護裝置，而且切勿讓其他同行的幼童觸摸保護裝置。  

- 請勿單獨使用靠背部分。  

- 請勿把幼童保護裝置作一般座椅使用。由於座面及靠背並不固定，當成一般座椅使用有可能引致意外翻倒。  

- 請小心勿讓車門或其他可動部份夾住幼童保護裝置。  

- 請勿擅自改造本幼童保護裝置，或以本說明書記載以外的方法操作本幼童保護裝置。  

- 請勿讓幼童自行使用幼童保護裝置。  

- 請勿使用未安裝座墊的兒童安全座椅，而且請勿自行更換部件。（以免影響受衝擊時兒童安全座椅的安全性）。  

- 請勿在汽車座椅和幼童保護裝置之間放置其他椅墊等物件。  

- 座席的表面素材（皮革等）由於形狀的不同，會使安裝后的座席出現刮痕。  

- 請勿讓本產品暴露於風雨之中。  

- 請勿放置不穩固的物件在車內，以免緊急煞車時幼童被物件所傷。  

- 不要手執兒童安全帶來搬運幼童保護裝置。  

- 指甲較長或者使用水晶甲的使用者，操作或調節請加倍小心，以免指甲被夾到或卷入插扣裡面。  

使用前請詳細閱讀

## 組裝方法

### 組裝方法

座部及靠背在銷售包裝中是未組裝的。當使用幼童用座椅模式(P.13)和學童用座椅(I)模式(P.21)時，請將靠背組裝到座部再使用。

#### ⚠ 注意

- 組裝時請在平坦和柔軟的地面上進行，可避免令產品或地面受損。
- 組裝時，請注意周圍沒有其他人，以免夾到手指。
- 請小心不要被座部及靠背的間隙夾到手指。
- 請注意別讓兒童安全帶夾在靠背及學童用座椅(I)之間。



接合部分

#### 安裝靠背

# 1

確認安全帶沒有扭轉，把靠背和座面如下圖般放在地上，整理好兒童安全帶。

\*以幼童用座椅使用時，把插扣扣上。



**✦** 小提示

組裝前請確認安全帶沒有扭轉。

# 2

拉起兒童安全帶，確認左右的鈕扣位置在兒童安全帶穿孔的上方。



#### ⚠ 警告

- 左右的鈕扣位置在兒童安全帶穿孔的下方時，不能使用本產品。

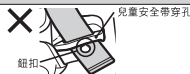

鈕扣

# 3

- ① 檢查靠背後方的幼兒腰帶是否在接合處下方穿過，並調整靠背的固定爪至座椅面的接合處。
- ② 慢慢抬起靠背直至靠背的固定爪與座椅面的接合處穩定接合。

\*EG型號，繫上附加護腰墊安裝帶(下部)第12頁。

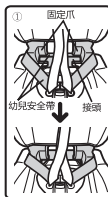

① 固定爪

幼兒安全帶

接合處

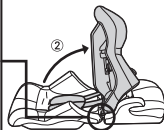

②

#### ⚠ 注意

- 確實檢查靠背後方的幼兒腰帶是在接合處下方穿過。



幼兒腰帶穿過接合處。

#### ⚠ 注意

使用本產品前請務必確認以下內容。否則本產品將不能發揮應有功能，並構成危險。

- 使用幼童用座椅時確認兒童安全帶沒有通過手靠外側。
- 確認兒童安全帶沒有夾入靠背與座面的接合處。



夾著兒童安全帶

#### ⚠ 警告

- 讓幼兒坐下前，請先確認靠背及學童用座椅已穩固的組裝。
- 檢查靠背的左及右固定爪確實接合至座椅面的接合處。



拆掉靠背的固定爪



# 10

← 拆除靠背時，請以與安裝相反的順序去進行。

拆除靠背

## 組裝方法

### 杯托的安裝和使用方法

杯托可隨意安裝於學童用座椅的左方和右方。

#### 警告

- 請勿將熱飲放於杯托中，以防燙傷。
- 請勿將杯托安裝於汽車前座位置，以免影響操控汽車手剎桿及變速器。

### 安裝杯托

- ① 將座椅座面翻至底部。
- ② 把杯托的爪牢固地推入座椅底部表面的安裝插座。
- ③ 嘗試拉動杯托確認已經安裝牢固。

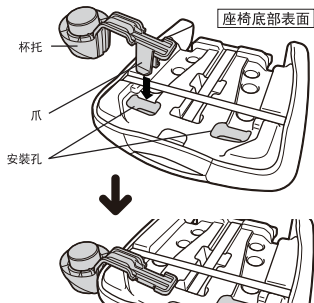

### 拆除杯托

- ① 從座椅底部表面拆除橡皮筋，及將座墊的前側翻開。
- ② 握著兩個固定爪向內按。
- ③ 從座椅底部表面拉出杯托。

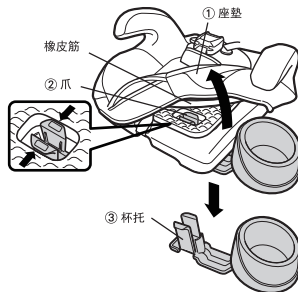

#### 注意

- 請將杯托裝置於打開汽車門的另一方，謹防杯托卡在汽車門和幼童保護裝置之間。
- 請注意及避免兒童將身體依靠於杯托，否則會引致杯托損壞。
- 杯托並不適用於所有尺寸的杯子，請確保杯子和杯內飲料能固定於杯托中方可使用。

## 護頭墊、護腰墊(僅限EG)的安裝及使用

### 使用及安裝護頭墊及護腰墊

頭墊及腰墊僅可於9-15kg以下(不含15kg)之幼童階段使用。  
請按照幼童的體形選擇使用。

#### ⚠ 注意

- 請勿將拆下的頭墊、腰墊任意放在車廂之內，以免急剎車時頭墊、腰墊在車廂內滾動影響駕駛。
- 搬運幼童保護裝置時請勿手執頭墊、護腰墊移動本幼童保護裝置，以免產品意外掉落而損壞。
- 請依照本說明書內記載的使用方法來使用護頭墊、護腰墊。

### 安裝護頭墊

- 1 把護頭墊的帶子扣，穿過兒童安全帶的肩帶穿孔，
- 2 再把上端的帶子扣從靠背上方翻到背後。

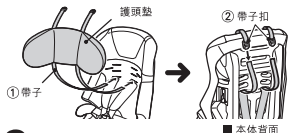

\* 請按照安裝相反的順序拆除護頭墊。

拆除護頭墊

### 安裝護腰墊

- 1 檢查護腰墊的前、後，右及左側，並將護腰墊安裝帶(上)(下)插入靠背的護腰墊安裝孔(上)(下)。

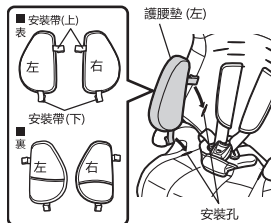

- 安裝完成後，請檢查以下確保護腰墊正確安裝。

- 以幼童用模式使用本產品時，幼兒腰帶應從護腰墊安裝帶後方穿過。

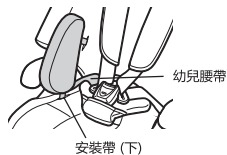

◀ 拆除護腰墊時，請以與安裝相反的順序去進行。

拆除護腰墊



## 使用幼童用座椅 (9-18公斤)

### 使用前的準備

體重條件	9-18公斤
身高參考	70-105釐米
年齡參考	1-4歲
使用方法	使用汽車安全帶將幼童保護裝置固定，用兒童安全帶繫扣兒童。



小提示

如幼童的體重為15公斤以上，可使用學童用座椅(I)(P.21)及學童用座椅(II)(P.28)。

### 兒童肩帶的調節方法

請根據幼童肩的高度決定肩帶的穿孔位置。

- 決定肩帶穿孔的位置。  
讓幼童乘坐後並選擇正確的肩帶穿孔位置。

使用幼童肩膀上方的一對肩帶穿孔。

#### 警告

- 請使用幼童肩膀上方的一對肩帶穿孔。
- 注意左右肩帶穿孔高度相同。



\* 中央帶的長度不可以調節，請調節肩帶。

使用幼童用座椅

## 使用幼童用座椅 (9-18公斤)

配合幼童肩膀的高度來調節肩帶。

### 1 拉出兒童安全帶

- ① 在按下座墊下面的安全帶調節按鈕 PUSH 的同時，
  - ② 手持左右的兒童安全帶向前拉直至盡頭。
- \* 即使拉動肩帶套也不能鬆脫兒童安全帶，必須要拉動出兒童安全帶。

小提示

- 為避免幼童自行解扣，插扣按鈕設計上需要用力才能開啟。
- 當按下安全帶調節按鈕時，請確定按壓在「PUSH」的標記上。
- 當安全帶調節按鈕難以按壓時，請先拉出兒童安全帶，然後按壓安全帶調節按鈕。

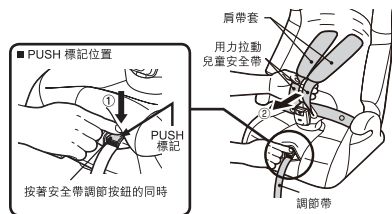

### 2 拆除兒童安全帶。

- ① 將兒童安全帶從本體背面的調節金屬解下。
  - ② 從肩帶套拉出兒童安全帶。
- \* 即使拉動肩帶套也不能解除兒童安全帶，必須要拉動出兒童安全帶。

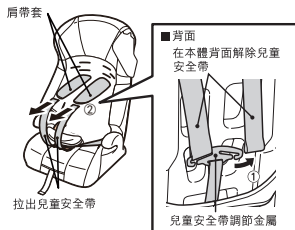

### 3 改變肩帶套的位置

- ① 在椅背分別拉出左右的肩帶套。
  - \* 當肩帶套難以拉出時，請從座椅正面將肩帶套基部按入肩帶穿孔中，然後從座椅背面將其拉出。
  - \* 在左、右的肩帶套通過連接帶連接至本體背面。
- ② 將肩帶套重新穿回合適的肩帶穿孔之內。
  - \* 請參照P13「兒童肩帶的調節方法」。

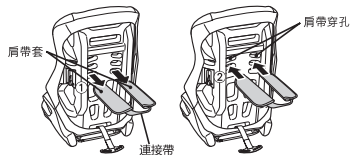

## 使用幼童用座椅 (9-18公斤)

### 4 安裝兒童安全帶。

- 1 注意兒童安全帶沒有扭曲，將兒童安全帶重新穿回肩帶套之內。
- 2 在椅背拉出兒童安全帶。
- 3 將兒童安全帶扣上兒童安全帶調節金屬。

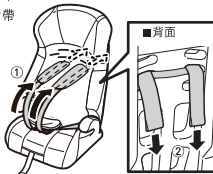

#### ⚠ 注意

- 調節帶和安全帶調節金屬必須要通過本體及座墊之間。

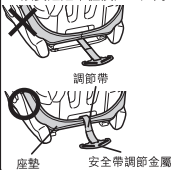

#### ⚠ 警告

- 確保兒童安全帶正確安裝

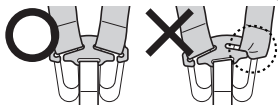

#### 安裝上的注意事項

此說明安裝上的注意事項以及安裝方法。本幼童保護裝置可能無法安裝在個別形狀特別之汽車座席上。詳情請參照第6頁。

#### ⚠ 危險

- 未能牢固安裝的幼童保護裝置將不能發揮預設的保護功能，更會引致危險。因此請嘗試在其他適合的汽車座席上進行安裝。
- 安裝時請勿以繩索等安全帶以外的物件代替安全帶進行安裝。
- 請勿安裝於設有汽車安全氣囊的座席上。發生意外時，彈出的汽車安全氣囊會對幼童造成很大的衝擊，引致危險。
- \* 只有汽車安全氣囊在側面的汽車座席才可進行安裝。

#### ⚠ 警告

- 安全帶有破損時，請勿在該座席上進行安裝。
- 即使沒有幼童乘座時，也必須以安全帶將幼童保護裝置固定安裝。
- 假如安裝在前座乘客座席上影響司機操作變速器或手煞車等功能時，請改為安裝在後座上。
- 假如2門或3門汽車後座載有乘客，請勿將幼童保護裝置安裝在前座乘客座席上，以免意外時保護裝置阻礙乘客逃出。

#### 安裝前準備

- 1 請將汽車停放在平地，以及在兩邊車門能完全打開的地方進行安裝。

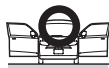

- 2 為方便進行安裝，請將前座座椅滑向前方，並將椅背往前傾斜。



## 使用幼童用座椅 (9-18公斤)

小提示

- 有關具有滑動功能的汽車座椅
- ① 欲安裝之座椅假如具有滑動功能時，請將汽車座椅滑動至最後位置。
- ② 完成安裝後再將汽車座椅滑向前方，則能令幼童保護裝置安裝得更加方便。



- 2** 調節汽車座椅的靠背角度配合幼童用座椅，可令安裝更加牢固。假如汽車座椅的靠背角度可以調節，請調節角度配合幼童用座椅主體角度。

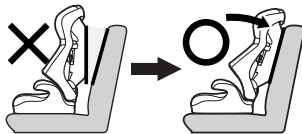

### 汽車座椅的準備

- 1** 如果汽車座椅的頭靠為可拆卸式，請先行把頭靠解除下來。

- ① 將可拆卸設計的汽車座椅上的頭靠拆除。
- ② 若汽車安全帶是可調節設計，必須將它調至最低。
- ③ 設置幼童用座椅在汽車座椅上。



前向模式  
汽車行駛方向

### 警告

- 安裝於汽車座椅時請盡量調節靠背至垂直角度，將幼童汽車座椅的靠背裝設於汽車座椅靠背(垂直計算)15度左右位置。
- \* 請使用印在使用說明書封底的角度確認器確認正確的角度。
- 如汽車座椅與幼童保護裝置間存有過大的空間，會十分危險。

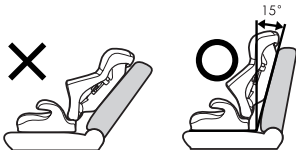

## 使用幼童用座椅 (9-18公斤)

### 安裝到汽車上

#### 1

##### 安裝汽車上的安全帶

- ① 小心慢慢拉出汽車座席上的安全帶，注意不要扭曲。
- ② 拉出汽車安全帶並穿過安全帶導引。
- ③ 確認車輛安全帶沒有扭曲。
- ④ 將安全帶穿過保護裝置另一側的安全帶導引。
- ⑤ 扣上插扣座直至聽到「咔嚓」一聲。

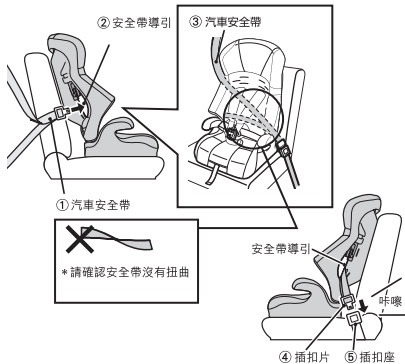

#### 2

##### 安裝汽車安全帶(車輛肩帶)部分

- ① 打開插扣座相反一方的鎖緊裝置
- ② 將車輛肩帶夾入鎖緊裝置最上部分，然後按下鎖緊裝置並關上。

小提示

- 即使鎖緊裝置可以自動關閉，但是為了穩固地安裝車輛肩帶，請在安裝後輕輕按下鎖緊裝置以關閉。

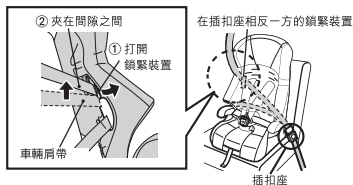

#### 警告

- 請勿使用插扣座一方的鎖緊裝置。
- 只可使用插扣座相反一方的鎖緊裝置。

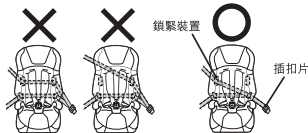

\* 請按安裝的相反順序拆除

### 拆除方法

## 使用幼童用座椅 (9-18公斤)

### 牢固安裝到車上的方法

- 1** 把汽車安全帶儘量收緊，令幼童用座椅更加固定。
- ① 將膝蓋放在座面中央，加以體重令幼童用座椅更加緊貼汽車座席。
  - ② 用力向上拉扣在汽車安全帶插扣座上的汽車安全帶肩帶，並抽緊汽車安全帶腰帶。
  - ③ 用另一支手，沿箭頭方向用力拉鎖定結構部分的汽車安全帶肩帶，抽緊汽車安全帶肩帶。



- 加以自己的體重的同時，請重複第②和③。

使用幼童用座椅

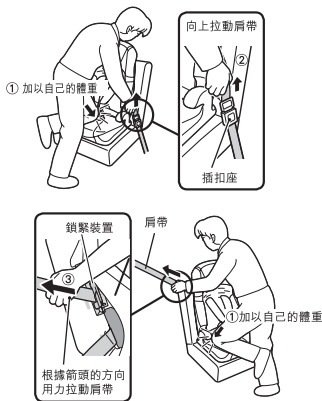

### 完成安裝後的檢查

完成安裝後請確認以下事項：

- ① 汽車座席及幼童用座椅之間沒有很大的空隙。
  - ② 插扣片已經緊扣於插扣上。
  - ③ 汽車座椅安全帶不得出現鬆弛、下垂、扭轉問題。
  - ④ 帶根部分沒有鬆弛。(請參考第19頁)
  - ⑤ 安全帶(左右車輛腰帶部分)已經正確地穿過腰帶導引。
  - ⑥ 車輛肩帶通過汽車插扣座相反一方的鎖緊裝置並鎖緊。
  - ⑦ 抓住側面部分前後搖晃，座面不得出現大幅度晃動。
- ※ 由於幼童用座椅的設計，座面有可能會上下移動，但是可安心使用。

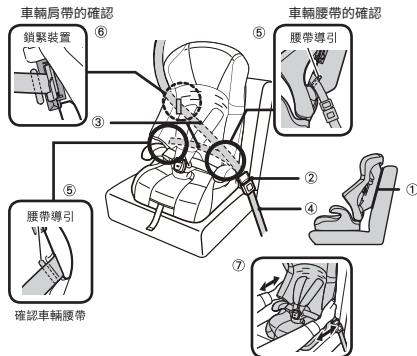

## 使用幼童用座椅 (9-18公斤)

有任何詢問請聯繫當地經銷商

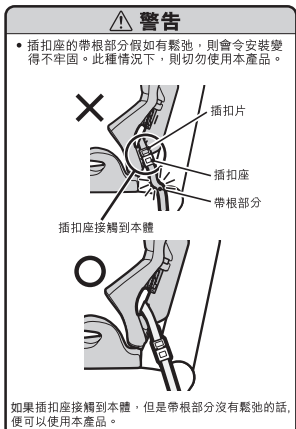

如發現幼童用座椅未作固定，請按照P.16-19重新安裝及檢查。

如果仍然無法固定請選擇於其他汽車座席上安裝。否則，可能會影響幼童用座椅的功能，更會引致危險。

### 讓幼童乘坐

配合幼童的體型請調節安全帶穿孔位置。(請參考P.13)



- 1** 拉出兒童安全帶。
- 按安全帶調節按鈕的同時，
  - 將左右的兒童安全帶向前拉出，鬆開安全帶。(參照下圖)
- \* 拉扯肩帶套不能調節肩帶，請拉扯兒童安全帶。

**小提示**

- 為避免幼童自行解扣，故安全帶調節按鈕的位置較難發現。
- 請確認按著「PUSH」這個標記。
- 待調節鈕按不動時，一邊將左右的兒童安全帶向前拉，一邊用力按下兒童安全帶調節鈕。

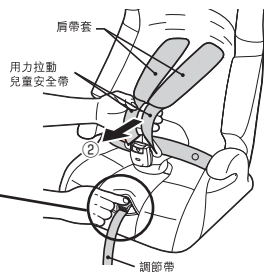
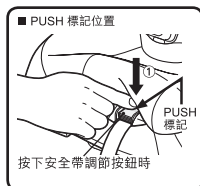

加長兒童安全帶 (當抱放孩子時)

## 使用幼童用座椅 (9-18公斤)

### 使用幼童用座椅

- 2** 解除插扣片
- ① 按下插扣按鈕。
  - ② 取出插扣片。



插扣片

- 3**
- ① 讓幼童坐入幼童用座椅內，兩臂穿過左右的兒童安全帶。
  - ② 配合左右的插扣片，然後插進插扣座，直至聽到「咔嚓」一聲鎖定為止。

請確認兒童安全帶沒有扭曲

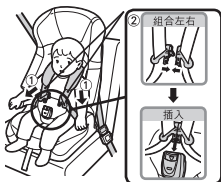

小提示

- 為避免幼童自行解扣，插扣按鈕設計上需要用力才能開啟。

- 4** 請確認鎖緊顏色顯示器是否轉為綠色。



顯示器由紅色轉為綠色

### 警告

- 若左右插扣片沒有正確地扣上及顯示器沒有呈現為綠色，這有可能令幼童遇交通事故時有被拋出的危險，或令安全帶纏繞幼童頸部，引致窒息。

- 5** 縮短兒童安全帶

- ① 請盡量將腰帶拉低，使腰帶能固定幼童骨盆的位置。
- ② 肩帶應放在幼童肩部的中間位置。
- ③ 將調節帶向前拉出，應配合幼童的體型調節兒童安全帶的長度。



① 幼兒腰帶

② 幼兒肩帶

③ 將調節帶往前拉

請儘量將腰帶拉低，令其能固定在幼童骨盆位置。

小提示

- 調節時，請注意不要過緊或過鬆。
- 請注意在幼童與兒童安全帶之間，留有一大的一隻成人的手的空間較為合適，在安全帶太緊或太鬆的時候，請調節兒童安全帶的長度。
- 如欲放鬆兒童安全帶，請參考P.19「加長兒童安全帶」。

### 警告

- 兒童安全帶必須調節至左右長度相同。兒童安全帶不配合幼童體形，幼童於意外時便有跌出幼童保護裝置之危險。
- 兒童安全帶不能太鬆，否則便有纏繞幼童頸部而引致窒息的危險。





## 使用學童用座椅(I)模式(15-25公斤)

### 使用前的準備

體重條件	15-25 公斤
身高參考	95-125 釐米
年齡參考	3-7 歲
使用方法	拆除兒童安全帶用汽車安全帶直接繫扣兒童，並按兒童肩膀的高度使用肩帶導引。



### ⚠ 危險

- 請確保裝置於3點式安全帶的座席上。切勿裝置於2點式安全帶上。否則，會影響幼童保護裝置的功能及可能引致危險。
- 即使無人乘坐幼童保護裝置，也請以安全帶固定幼童保護裝置。否則，若遇突如其來的剎車，可能會產生潛在的危險。

### ⚠ 警告

- 必須使用肩帶導引以免在意外時因肩帶滑落而造成危險。
- 假如座席上具備幼童保護裝置的固定功能，請先將該功能解除，否則幼童可能因為過度的約束胸部受壓。(詳細參考P.5)
- 請勿在安全帶鬆弛的狀態下使用幼童保護裝置，以免意外時安全帶纏繞脖子而引致窒息。
- 請勿安裝於安全帶已破損的座席上。

### 變更為學童用座椅(I)模式的方法

如之前以幼童用座椅模式(P.13)使用，請先拆除兒童安全帶及釦子。

### ⚠ 注意

- 在變更使用模式時，請先拆除幼童保護裝置。

### 拆除兒童安全帶

#### 1 拉出兒童安全帶

- 拼合左右插扣片，然後一同插進插扣座中，聽到「咔嚓」一聲為止。
  - 按下安全帶調節按鈕上的「PUSH」，然後將左右的兒童安全帶拉出。
  - 手執兒童安全帶左右，向前用力拉出。
- ※ 拉扯肩帶套不能調節時，請拉扯兒童安全帶。



小提示

- 為避免幼童自行解扣，故安全帶調節按鈕的位置較難發現。
- 按壓安全帶調節按鈕時，確保確實有按著「PUSH」按鈕。
- 待調節鈕不動時，一邊將左右的兒童安全帶向前拉，一邊用力按下兒童安全帶調節鈕。

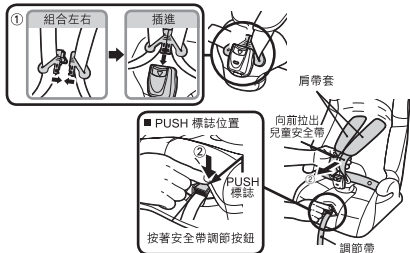

## 使用學童用座椅(I)模式(15-25公斤)

### 2 拆除兒童安全帶。

- ① 把左右的兒童安全帶，從主體背面的安全帶調節金屬上解下。
  - ② 把兒童安全帶從肩帶套上抽出。
- \* 拉扯肩帶套也不能令兒童安全帶除下。必須拉扯兒童安全帶。

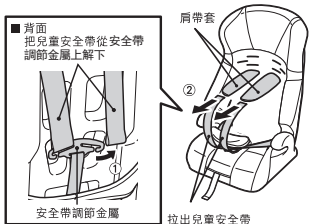

### 3 拆除肩帶套。

- 從椅背分別拉出左右的肩帶套。
- \* 在左、右的肩帶套通過連接帶連接至本體背面。

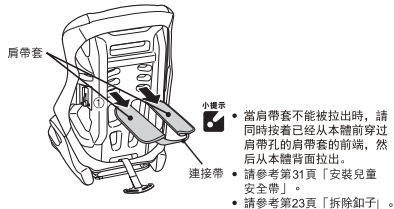

- ③ 把左右的兒童安全帶從安全帶調節金屬解下。
- ④ 在主體後方，把兒童安全帶從穿孔中慢慢抽出。

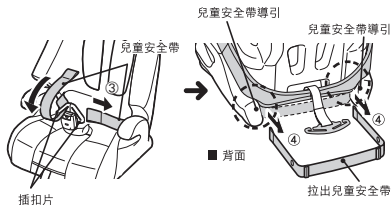

- 抽出前請從正面確認兒童安全帶沒有扭轉。

## 使用學童用座椅(I)模式 (15-25公斤)

### 拆除釦子

主體處於不安定的狀態。操作前請先把座面從靠背上拆下(P.10)。

- ① 在座面的底部，把兒童中央帶的固定金屬環慢慢拉出少許，然後以垂直的角度把金屬環穿出座面。
- ② 在座面的上方將中央帶抽出。

小提示

- 建議在座面的上方按著中央帶，則可更容易的把固定金屬環拆下。

### 警告

- 安裝固定金屬環時，請在安裝之後拉扯中央帶以確認其已經固定。

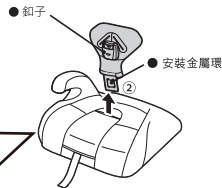
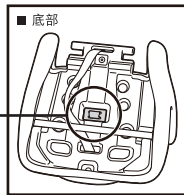

\* 安裝時把中央帶的固定金屬環以垂直的角度慢慢推進穿孔到座面的底部。

### 注意

- 拆除靠背及兒童中央帶後，方可安裝幼童保護裝置。
- 請小心處理拆下來的部件，以免遺失。

■ 兒童安全帶



肩帶套



兒童安全帶

■ 中央帶

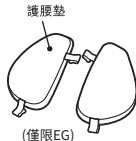

(僅限EG)

小提示

- 為了不讓插扣片丟失，請將插扣片扣緊在插扣座上。
- 請參考第21頁「拆除兒童安全帶」。

### 安裝方法

\* 請按與拆除相反的順序安裝

## 學童用座椅(I)模式 (15-25公斤)

### 收納安全帶調節金屬

#### 收納安全帶調節金屬

拆除靠背，座墊及泡棉後，才收納安全帶調節金屬。

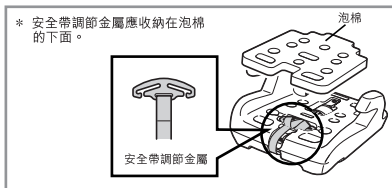

- 1 按下安全帶調節按鈕。
- 2 將安全帶調節金屬拉至最盡頭。

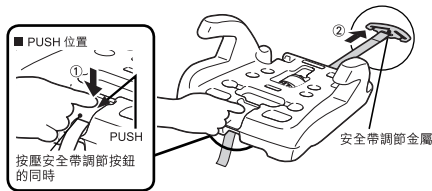

按壓安全帶調節鉤時確保確實有按到「PUSH」按鈕。

- 1 安全帶調節金屬應通過靠背與座椅之間的調節帶穿孔中拉出。

#### ■ 底部 安全帶調節金屬

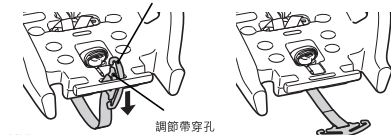

小提示

■ 請參考第30頁「安裝安全帶調節金屬」。

- 3 收納安全帶調節金屬

- 1 把安全帶調節金屬放在座面的正面。
- 2 將調節帶均等地捲在安全帶調節金屬上。
- 3 把安全帶調節金屬放入收納部分。

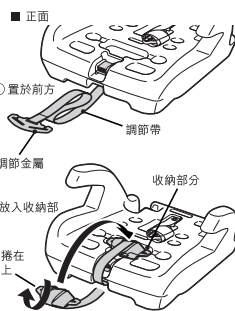

## 使用學童用座椅(I)模式 (15-25公斤)

### 準備肩帶導引

#### 準備肩帶導引

拆除靠背(P.10)，座墊及泡棉後(P.33)，才取出肩帶導引。

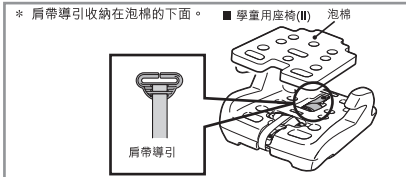

小提示

☑ 請參考第30頁「收納肩帶導引」。

**1** 從收納部取出肩帶導引。

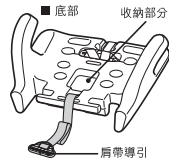

**2** 重新安裝座墊。  
(參考第33頁)

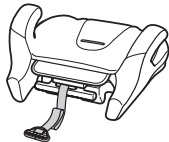

從此頁起，請在安裝靠背之後再進行操作

**3** 將肩帶導引通過本體與座墊之間。

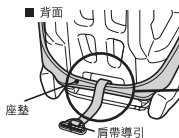

**4** 安裝肩帶導引。  
① 肩帶導引必須穿過與插扣座相反一方的穿孔。  
② 將肩帶導引拉至本體正面。

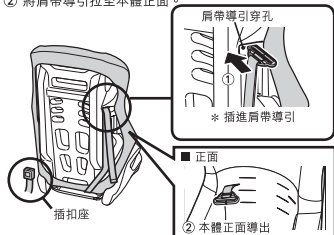

### 警告

• 請勿將肩帶導引穿過肩帶穿孔，請務必將肩帶導引穿過肩帶導引穿孔。

## 使用學童用座椅(I)模式 (15-25公斤)

### 安裝到車上

#### 警告

- 安裝於汽車座席時，請儘量調節靠背至垂直角度。若幼童汽車座席裝設於過分平躺的汽車座席上時，可能會引致危險或令幼童意外跌出。幼童頭部可能因過鬆的安全帶而被動而引致窒息。
- 將幼童汽車座席的靠背裝設於汽車座席靠背(垂直計算)15度左右位置。
- 請使用印在使用說明書封底的角度確認器確認正確的角度。

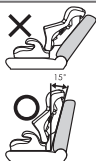

- 1 將可拆卸設計的汽車座席的頭靠拆除。
- 2 若汽車安全帶是可調節設計，必須將它調至最上段位置。

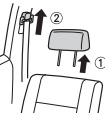

- 2 設置學童用座椅(I)在汽車座席上，拉出汽車安全帶。

- 1 穿過車輛肩帶導引。
- 2 將車輛腰帶穿過左右扶手下側的腰帶導引。
- 3 將汽車安全帶插到插扣座中直至聽到「咔嚓」一聲。

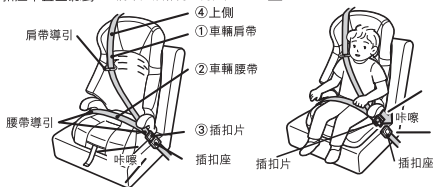

#### 注意

- 即使無人乘坐學童用座椅(I)，也需要將本產品如圖般穩固裝設。

### 讓兒童乘坐

讓兒童坐於學童用座椅深處。

#### 警告

- 請勿讓幼童如下圖錯誤乘坐。否則，可能會影響幼童汽車座椅的功能，更會引致危險。
- 如幼童保護裝置沒有以汽車安全帶繫緊會引致其不穩定。請勿讓幼童自行使用幼童保護裝置，必須有保護者陪同的情況下才可使用。

- 幼童乘坐時不得將身體向前傾斜。
- 幼童乘坐時不得將身體傾側於左或右方。
- 幼童坐姿要端正，乘坐時不得將腳放於座面上。



將插扣暫時解除。讓幼童坐於幼童保護裝置深處，如圖拉安全帶及牢固插扣至咔嚓聲響。

- 請儘量將車輛腰帶拉低，令其能固定在幼童骨盤位置。



#### 警告

- 幼童手臂是不能放置於腰帶下方的位置。



#### 注意

- 請注意勿讓幼童的衣服夾於靠背和學童用座椅之間的接合位置。

## 使用學童用座椅(I)模式 (15-25公斤)

### 肩帶導引的調節方法

請讓兒童坐在學童用座椅(I)上，根據兒童肩膀的高度來調節肩帶導引的長度。

肩帶導引是放置於學童用座椅(II)泡棉的下面。

#### 肩帶導引的正確位置

請確定肩帶導引要調節至跟幼童肩膀同等高度如圖示。並讓汽車安全帶可以配合幼童身體，肩帶導引盡可能靠近幼童肩膀。



#### ⚠ 警告

- 請調節車輛肩帶導引以切合兒童肩膀的高度。
- 請根據兒童的成長速度來調節肩帶導引的高度。



延長



縮短



系安全帶

假若肩帶從肩帶導引脫下，請重新繫上肩帶，如下圖。



## 完成安裝後的檢查

### 完成安裝後的檢查

幼童乘坐和繫扣安全帶後，檢查以下的事項。

- ① 將學童用座椅緊貼於汽車座席靠背位置。
- ② 肩帶從靠背上側通過。
- ③ 肩帶通過肩帶導引，肩帶部份沒有扭曲且沒有勒著幼童頸部或於幼童肩膀上過分鬆馳。
- ④ 安全帶已恰當地裝上、沒有扭曲及沒有鬆脫。
- ⑤ 安全帶(腰帶部分)已經固定幼童骨盤位置。
- ⑥ 插扣片已經繫扣於插扣上。
- ⑦ 安全帶(車輛肩帶和車輛腰帶部)已經正確地穿過腰帶導引。

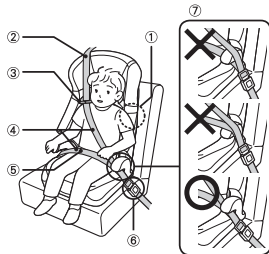

#### ⚠ 警告

- 如發現幼童保護裝置未作固定，請按照P.26重新安裝及檢查。
- 如幼童頸部已高過頭靠時，請拆除靠背以學童用座椅(II)模式使用，否則會影響幼童用座椅的保護功能，更會引致危險。

## 使用學童用座椅(II)模式 (22-36公斤)

### 使用前的準備

體重條件	22-36 公斤
身高條件	125-145 釐米
年齡參考	6-11 歲
使用方法	先將兒童安全帶與靠背拆除,只留座面,為了使車輛肩帶配合兒童的身體,需使用肩帶導引。



### 學童用座椅(II)模式

28

### ⚠ 危險

- 請確保裝置於3點式安全帶的座席上。切勿裝置於2點式安全帶的座席上。否則,會影響幼童保護裝置的功能及可能引致危險。
- 即使無人乘坐幼童保護裝置,也請以安全帶固定幼童汽車座椅。否則,若遇突如其來的剎車,可能會產生潛在的危險。

### ⚠ 警告

- 假如座席上具備幼童保護裝置固定功能,請先將該功能解除。否則幼童可能因為過度約束感到胸部受壓。(詳細參考P.5)
- 請勿在安全帶鬆弛的狀態下使用保護裝置,以免意外時安全帶纏繞脖子而引致窒息。
- 請勿安裝於安全帶已破損的座席上。
- 必須使用肩帶導引以免在意外時因肩帶滑落而造成危險。

### 模式變更方法

- 由幼童用座椅模式變更時,請參考 P.13-20。
- 從學童用座椅(I)變更時,請先拆除肩帶導引P.30及靠背P.10。

### 安裝到車上

### ⚠ 警告

- 安裝於汽車座席時,請儘量調節靠背至直立角度。若幼童汽車座椅裝設於過份平躺的汽車坐席上時,可能會引致危險或令幼童容易跌出。幼童頸部也可能因過松的安全帶而被勒以引致窒息。



- 1** 將之前已拆除的汽車座席頭靠重新安裝。  
**2** 若汽車安全帶是可調節設計,必須將它調至最低。



- 2** 將學童用座椅(II) 放置在汽車座椅上, 拉出汽車安全帶后
- ① 穿過車輛肩帶導引。
  - ② 將腰帶穿過左右扶手下側的腰帶導引。
  - ③ 將汽車安全帶插到插扣座中直至聽到卡嗶一聲。

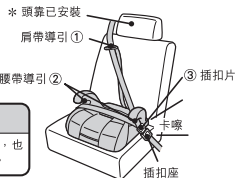

### ⚠ 注意

- 即使無人乘坐學童用座椅(II), 也需要將本產品如圖穩固裝設。



## 學童用座椅(II)模式(22-36公斤)

### 兒童乘坐前的準備

將插扣暫時解除。  
讓兒童坐於學童用座椅(II)深處，拉出汽車安全帶。

- ① 將汽車安全帶通過左右扶手下的腰帶導引。
  - ② 將汽車安全帶插到插扣座中直至聽到咔嚓一聲。
- \* 請盡可能將腰帶拉低，令其能固定在幼童骨盆位置。



### 肩帶導引的調節方法

讓幼童坐於學童用座椅深處，然後配合幼童肩膀的高度來調節肩帶導引。

- \* 肩帶導引是存放在學童用座椅(II)的泡棉下。



#### 肩帶導引的正確位置

請確定肩帶導引要調節至跟幼童肩膀同等高度如圖示。致令學童用座椅(II)可以切合兒童的身體。

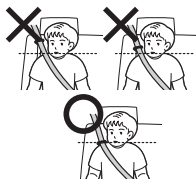

#### 延長



#### 縮短



#### 系安全帶

假若肩帶從肩帶導引脫下，請重新繫上肩帶，如下圖。



#### 警告

- 請調節車輛肩帶導引以切合兒童肩膀的高度。
- 請根據兒童的成長速度來調節肩帶導引的高度。

## 使用學童用座椅(II)模式

### 完成安裝後的檢查

幼童乘坐和繫扣安全帶後，檢查以下的事項。

- ① 汽車座席上的頭靠已經裝上。
  - ② 肩帶部分通過肩帶導引沒有緊勒著兒童頭部或於兒童肩上過分鬆弛。
  - ③ 安全帶已恰當地裝上安全帶，沒有扭曲及沒有鬆脫。
  - ④ 安全帶(腰帶部分)已經固定幼童骨盤間。
  - ⑤ 插扣片已經繫扣於插扣上。
  - ⑥ 車輛肩帶和車輛腰帶部分已經正確地穿過腰帶導引。
- \* 有任何詢問時請諮詢當地經銷商。

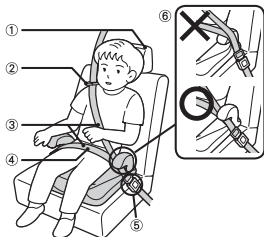

### 學童用座椅(II)模式

#### 警告

- 如發現學童用座椅(II)底座未作固定，請按照 P.28-29 重新安裝及檢查。
- 如學童用座椅(II)底座未能穩固，請選擇於其他汽車座席上安裝。否則，可能會影響學童用座椅(II)的功能，更會引致危險。

30

## 還原至幼童用座椅

### 收納肩帶導引

當作為幼童用座椅(P.13)使用時，請勿使用肩帶導引。請收納於座面收納部。

- 1 當作為學童用座椅(I)使用時，請先拆除肩帶導引。

#### ■ 本體背面

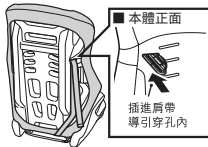

小提示

- 關於「肩帶導引的準備」請參考第25頁。

- 2 拆除靠背(P.10)，底墊和泡棉(P.33)。

- ① 將肩帶卷在肩帶導引上
- ② 然後放入座面收納部



### 安裝安全帶調節金屬

由學童用座椅(I)模式(P.26)或學童用座椅(II)模式(P.28)轉換為幼童用座椅模式時，把收藏在座面的安全帶調節金屬拿出，然後重新裝上椅墊和椅套。

\* 主體處於不穩定的狀態。操作前請先把學童用座椅(II)從靠背上拆下(P.28)。

#### ■ 學童用座椅(II)

- 1 把座面的椅墊及椅套拆下(P.33)，拿出安全帶調節金屬，然後重新裝上椅墊和椅套。

小提示

- 有關拆除安全帶調節金屬和收納到座面底部的的方法，請參照 P.24。

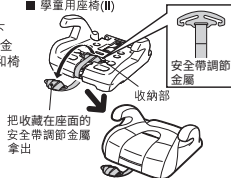

## 還原至幼童用座椅

### 安裝安全帶調節金屬

- 2 繼續調節帶不要扭曲。
- ① 從座面底部的橡皮帶下將調節帶穿過調節帶穿孔。

- ② 將安全帶調節金屬垂直插入調節帶穿孔。



#### ■ 座面底部部

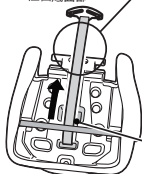

### 安裝兒童安全帶

使用幼童用座椅(P.13)，請把兒童安全帶安裝到靠背之上。  
\*主體處於不穩定的狀態，操作前請先把座面從靠背上拆下(P.10)。

- 1 把肩帶套安裝到肩帶之上。
- ① 把肩帶套從靠背後方穿過合適的肩帶穿孔到座椅前方。  
\*請參照「兒童肩帶的調節方法」(P.13)
- ② 把肩帶套從前方拉出。

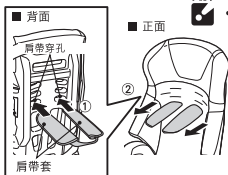

- 3 安裝兒童安全帶。
- 確認兒童安全帶沒有扭轉，
- ① 把兒童安全帶穿過靠背後方左右兩端的兒童安全帶穿孔，
- ② 慢慢的在正面把兒童安全帶拉出直到兒童安全帶的按鈕部分穿過穿孔為止。

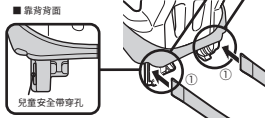

- 2 確認兒童安全帶的安裝方向。
- 確認兒童安全帶沒有扭轉，而且兒童安全帶的凸出部份在外側一方。

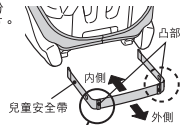

#### ■ 背面



- ② 在正面把兒童安全帶拉出。



#### 注意

左右的按鈕沒有穿過兒童安全帶穿孔時，不能使用本產品。



## 還原至幼童用座椅

從這裡開始，操作前請先把釦子(P.23)和靠背安裝好(P.10)。

- 4**
- ① 確認兒童安全帶沒有扭轉，把左右的兒童安全帶穿過插扣片。
  - ② 確認兒童安全帶沒有扭轉，把兒童安全帶穿過肩帶套，
  - ③ 再在靠背背面抽出。

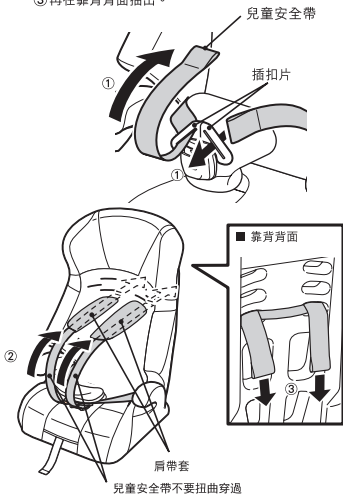

- 5**
- ① 將左右的兒童安全帶裝在安全帶調節金屬上。
  - ② 安全帶調節金屬和調節帶應通過本體及座墊之間。
  - ③ 將左右的兒童安全帶裝在安全帶調節金屬上。

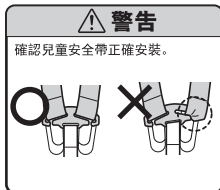
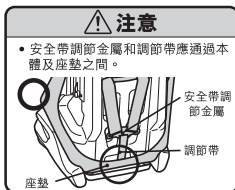
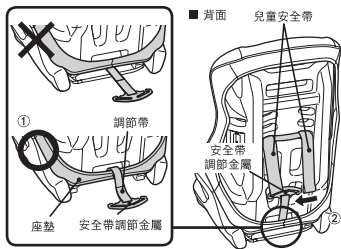

## 日常保養

### 護頭墊、護腰墊 (只限EG型)

請參考「使用及安裝護頭墊及護腰墊」(P.10)

### 拆除座墊 (靠背)

拆除兒童安全帶 (P.21)，拆除靠背 (P.10) 然後拆除座墊。

- ① 拆除座墊的上部分。
- ② 將座墊從靠背上拆下來。



小提示



安裝座墊時，必須將帶子部分穿過靠背。

### 裝拆織製品

#### 裝拆兒童安全帶

請參考P.21「拆除兒童安全帶」  
請參考P.31「安裝兒童安全帶」

#### 拆除座部的座墊

拆除靠背(P.10)，釦子 (P.23)，然後拆除座墊。

- ① 解除學童用座椅 (II) 底部的橡皮圈。
- ② 將座墊的前側向上翻，
- ③ 拆除袋狀部分，
- ④ 將座墊從扶手上拆除。

#### ■ 學童用座椅 (II)

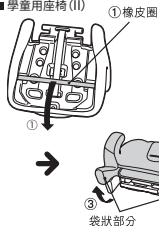

#### ■ 座面後側



#### ■ 座面前側

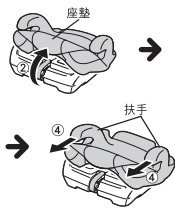

#### ■ 座面前側

小提示



請將泡棉配合兒童中央帶穿孔安裝。

請按照拆除的相反順序安裝座墊(靠背)

請按照拆除的相反方向安裝

## 日常保養 / 保存方法

### 座墊的清洗方法

請於清洗座墊時注意以下事項。

- 請遵守縫製品上所標示的洗滌指引。
  - 使用洗衣機清洗時請把衣物放進洗衣網，避免導致衣物鬆散等煩惱。
  - 濺水洗或弱速機洗。
  - 請勿使用漂白劑。
  - 清洗時建議使用中姓洗滌劑，使用含有螢光劑、漂白劑的清洗劑可能會引起皮膚粗糙、癢疹等，所以請不要使用這類清洗劑。
  - 橫型洗衣機（洗衣槽橫向，並且傾斜）使用的時候，請注意避免水量過少。
  - 由於產品的特性，有細微的脫色的可能。
  - 建議和其他的衣物分開清洗和脫水。
  - 輕輕擰乾後，整理好形狀，放於陰涼處晾乾。
  - 請勿使用熨斗熨燙。
  - 請勿使用乾燥機或乾洗。
  - 在清洗頭墊時，請先拆除裡面的泡棉。
  - 當清洗護腰墊（只限EG型）時，請先將裡面的泡棉拆除。
- ※ 護頭墊、護腰墊、座面裡面的泡棉是不可以清洗的。

### 本體、安全帶的保養方法

- 一般情況下使用濕布擦拭做清洗。如對於頑固的污垢，可使用追加已稀釋的中性清洗劑清洗。當清洗完畢後，放於陰涼處晾乾。

#### 警告

- 請勿使用未經稀釋的中性清潔劑、汽油或其他有機溶劑清洗主體，否則可能令主體及兒童安全帶造成損壞。

### 保存方法

- 主體：長時間不使用幼童保護裝置時，請將幼童保護裝置從車上座席拆下，並存放於陰暗處及幼童不能接觸的地方。
- 使用說明書：閱讀本使用說明書後，請將其存放於幼童保護裝置底部的說明書口袋中作日後參考之用。

### 泡棉

座墊及縫製品的染料可能會沾到泡棉上，品質是沒有問題的，請安心使用。

### 廢棄的方法

- 請按照住所的各地方政府的規章制度的章程來處理，廢棄。
- 兒童安全座椅經過強烈撞擊或從高處墜下會因撞擊後損壞而失去保護功能，即使表面沒有破損也絕對不能再使用。座椅及座椅套等縫製品請廢棄，請更換兒童安全座椅。

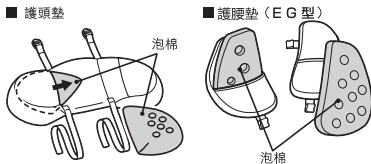

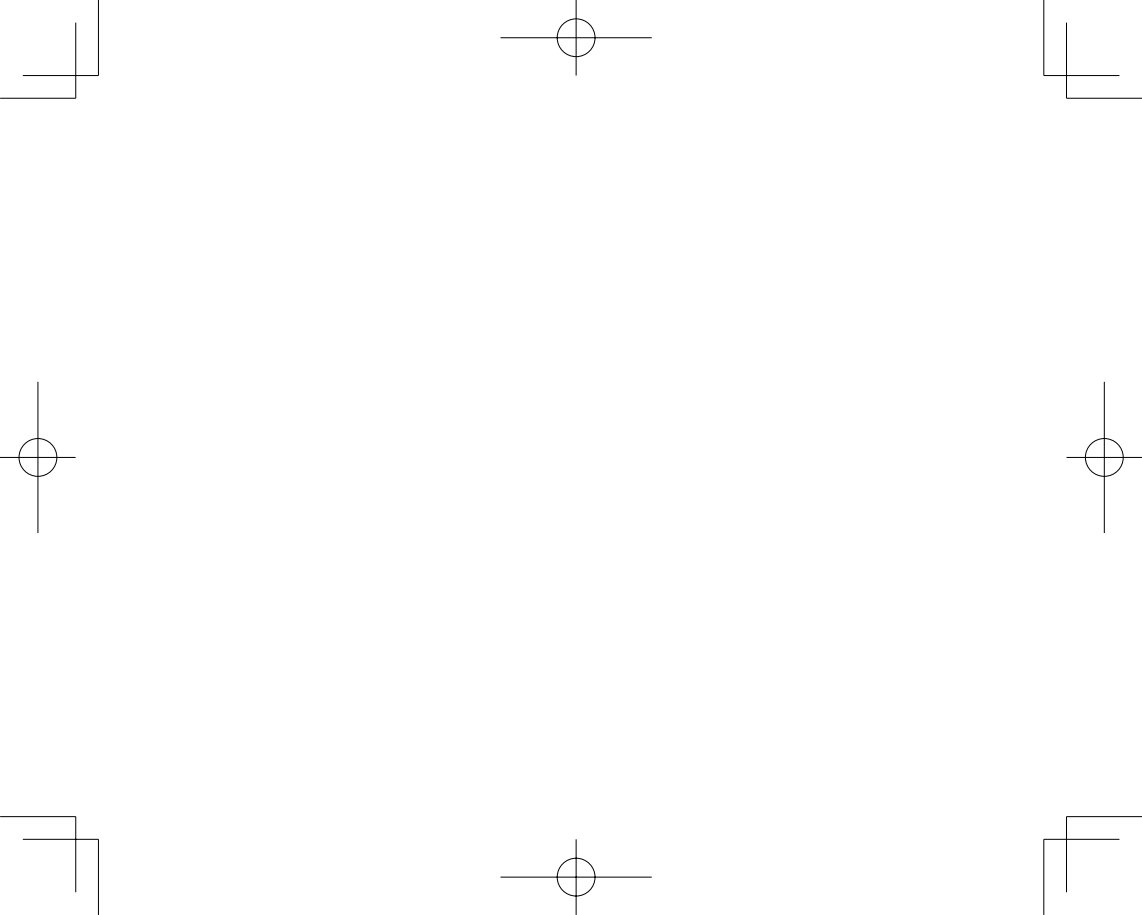

Please match this grey line against the seat cover of the backrest.  
請將此線靠在靠背。

#### Angle checker 角度確認器

Please use this angle checker to adjust the backrest to appropriate installation angle while using as Child mode (P.13) and junior mode (P.21).

使用幼童用座椅(P.13)和學童用座椅(I)(P.21)，請使用角度確認器來調至適當安裝角度。

Adjust the line become vertical when observing from right side.  
從主體右邊觀看時，應調節角度直至此線垂直。

Adjust the line become vertical when observing from left side.  
從主體左邊觀看時，應調節角度直至此線垂直。

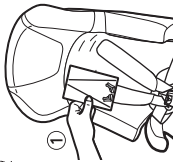

If the backrest of the vehicle backrest is adjustable, the backrest should lean against the vehicle seat at 15 degree.

1. Match the user guide against the seat cover of the backrest.
2. The backline should appear to be vertical if the leaning angle is around 15 degree.

如果靠背角度可以調節，請將靠背調節至向後傾斜15度左右。

1. 將本說明書放在靠背上。
2. 如黑線成垂直狀態時，則表示靠背約為15度。

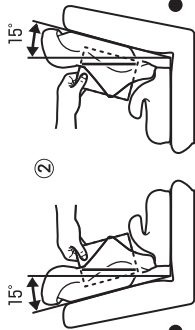

Main body-left  
本體左

Main body-right  
本體右

## Combi Corporation

Please match this grey line against the seat cover of the backrest.  
請將此線靠在靠背。