

# Combi

## Caldia

### 使用說明書 Instruction Manual

使用前請詳細閱讀本說明書，然後正確使用本嬰兒手推車。閱讀後請妥善保存作日後參考之用。若將本製品轉讓予他人使用時，請將本說明書也一併移交對方。

For safety of your children, read this instruction manual carefully and use the baby stroller accordingly. After reading, please keep this instruction manual for future reference.

Please also attach this instruction manual in case the stroller is to be transferred to others to use.



## 使用前 Before use

- 本產品為可供一名嬰兒或兒童乘坐的嬰兒手推車，可配合於戶外活動時使用。  
The product is a one-seat stroller designed to carry a baby or a little child for outside activities.
  - 建議連續使用時間：2 小時以內（約7個月左右的幼兒作座椅使用時則為1小時以內）  
Recommended continuous usage : within 2 hours. (Within 1 hour as sitting position for around 7 months old child)
  - 適合年齡：出生後1個月至36個月（因幼兒發育速度而各有不同）  
Applicable age : Newborn (1 month) till 36 months old. (May vary from child's growth rate)
- ※ 出生後1個月之幼兒指出生時體重在2.5公斤以上，懷孕期滿37週，然後超過1個月成長之幼兒。  
Newborn (1 month) baby refers to baby weights 2.5kg or above, has been carried for more than 37 weeks in pregnancy stage, was born for more than 1 month.

請於開封後確認所有部品已經齊全。

Check if any part is missing after opening the sales package.

包裝箱內應包括下列部品。請確認是否所有部品都已齊全。

The sales package should contain the followings. Make sure no part is missing.

沒有安裝在本手推車主體上的附屬品。

Accessories that are not attached to main body in sales package.



護頭墊  
Head support

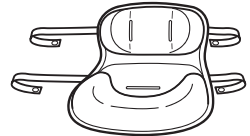

護背連臀墊  
Body & Hip Support



Egg Shock 墊  
Egg Shock pad

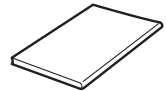

使用說明書 (本書)  
Instruction manual (this book)

## 安全使用守則 Safety guideline of using the stroller

- 本章節記載了需要您在使用上理解的警告和注意的內容。正確安全地使用，預先防止危害和損害的發生。  
This chapter records the warning and needed information. The stroller need to be used in compliance with instruction in order to avoid injury caused.

- 如果不遵守這裡所記載的內容，可能造成對孩子和使用者重大傷害的事故發生。  
請仔細閱讀並正確使用產品，這裡表示的注意事項是根據錯誤使用，對孩子和使用者產生危害以及對財產造成的預想損害。根據危害，損害的大小和程度，分別表示為“警告”和“注意”。請務必嚴格遵守。  
If the stroller is not used in compliance with the recorded content in this instruction manual, it may cause hazard to the child or the user. Please study carefully in order to use the product accurately. Labels classified as [WARNING] and [CAUTION] categorize the severity level of expected harm and damage caused by non-compliance to these instructions. Please follow accordingly.

<b>警告</b> WARNING	錯誤使用，可能造成人身死亡或重傷。 Misuse may result in severe injury or death.
<b>注意</b> CAUTION	錯誤使用，可能造成人身死亡或財產損失。 Misuse may result in injury or damage of product. (Loss on property)

- 必須遵守的內容按以下指示表示說明  
Please follow the instructions according to the labels.

	告知警告 / 注意等內容 Content of Warning/Caution
	告示禁止的行為 Content of Prohibition
	補充說明 Key point summary

### **警告WARNING** 錯誤操作可能引致嚴重意外 Misuse of the product may cause accidents.

#### 會引致手推車突然收合或嬰孩跌出車外等危險的錯誤操作 Misuse which may lead to accidentally folding of stroller or cause the child to fall off

- 開關鎖確實已鎖定(請確定推車已安全打開)後才可使用。  
Make sure the open-fold lock is fully engaged (when the baby stroller is fully open) before use.

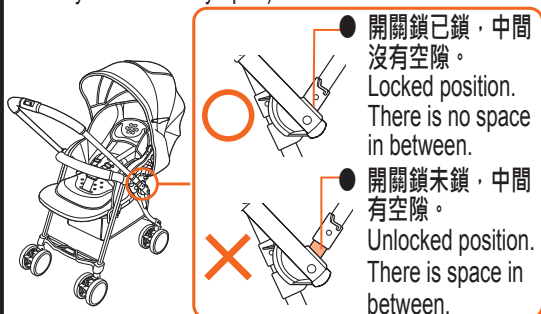

- 切勿搬動乘載了嬰孩的手推車，或手執前護欄等地方搬動手推車，以免手推車意外滑脫，或令前護欄鬆脫，引致手推車掉下。

Do not lift and carry the stroller while a child seated, or get hold of the front guard etc. to lift the stroller. Otherwise the stroller may accidentally slip off, or the front guard may be detach, all of which will cause the stroller to fall down.



- 不可於斜坡、階梯、自動電梯、顛簸道路、沙灘、泥地等場所使用手推車。  
Do not use the stroller on steep slopes, stairs, escalators, rough roads, beaches, mud, etc.



- 如手推車出現損壞或操作問題，應立即停止使用。  
In the event of damage or operation problems, stop using the stroller immediately.



#### 孩子跌落，推車折疊的危險發生 Dangers of a child falling off and folding the stroller.

- 使用前請用力拉動安全帶以確認所有安全帶已固定好。  
Please strongly pull the seat belt to ensure they are all tightly secure before use.
- 為避免意外，兒童應在任何時刻佩帶安全帶。  
Avoid serious injury from falling or sliding out.  
Always use seat belt.
- 孩子可能做出意想不到的動作，所以即使已用安全帶束縛，也可能跌落。所以請在成人監護下使用，務必十分注意。  
Pay attention to child even when seat belt is in use in case of any sudden movement of child causing it to fall off. The stroller should be used with guardian's attention.



- 不要讓孩子在推車上站立。  
Do not allow your child to stand in or on the stroller.



按照美國安全標準  
幼兒有可能滑進手推車的通腳口而被勒斃，只可於備有座位伸展及固定安全蓋套的情況下使用斜躺功能。  
For American Safety Standard Child may slip into leg openings and be strangled. Never use in reclined carriage positions unless the seat extension and the permanently attached safety cover are used.

**警告WARNING** 錯誤使用，可能引致重大事故的發生。 Misuse of the product may cause serious accidents.

**推車傾倒，孩子跌落的危險**  
Tipping over of the stroller and causing the child to fall off.

- 切勿懸掛包裹或物件於車篷或把手上，以免引致手推車翻倒。

Do not put or hang parcels or things on the canopy or handle to avoid tipping over of the stroller.

- 切勿懸掛物件在籃子以外的地方。手推車可能導致不穩定及下墜危險。此外，切勿施加負荷於把手或懸掛行李/物件於把手上。這都可能會導致手推車操作故障。

Do not hang any luggage onto the handle nor place anything other than into the basket. Stroller becomes unstable and it may fall down. In addition, do not apply excessive load by leaning on the handle or hanging any luggage onto the handle. It may cause malfunction of the stroller.



- 承載超重會容易產生不穩定的危險情況。

(座位最大容許載重量：十五公斤\*)

(置物籃最大容許載重量：五公斤\*)

Excessive weight may cause a hazardous unstable condition exist.

(Maximum load for seat : 15kg\*)

(Maximum load for basket: 5kg\*)

\*包括裝設在手推車上的部品(附設在包裝箱內)

Includes the accessories (provided in the sales package) equipped on the stroller.

- 請勿外加任何以輪板或組件於主體上乘載幼兒。Do not attach other accessory like buggy board on the main body during a child being carried in stroller.



- 請勿在斜坡上轉換把手。

Please do not reverse the handle on the slope.

- 請注意台階級差。當您越過不一樣台階的路邊，即使只有一小段也需慢慢推行手推車。請撐浮前輪及越過台階。若強行推動手推車越過台階，會令車輪受損壞。同時，這可能會導致手推車操作故障。

When you get over the difference in level of the curb, slow down the stroller even a little difference. Please float the front wheels and get over the steps. It will damage the wheels if forcing to push the stroller to get over the step. In addition, it may cause malfunction of the stroller.

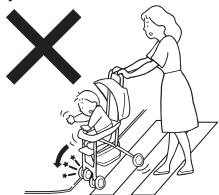

- 請勿一邊推動手推車，一邊轉換把手方向，以免引致危險。Do not reverse handle while pushing the stroller.

- 前向使用狀態時，請勿觸碰後腳管上的活動鎖。

Do not touch at the sliders on the rear leg tube when pushing in the forward facing direction.

- 將把手換成前向使用狀態時，請確認左右兩端後腳管上的活動鎖已經處於下方位置。

After switching the handle position from rear facing to forward facing, please check to make sure the left and right sliders on the rear leg tubes are on the lower position and engaged.

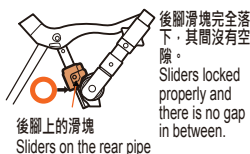

- 切勿把身體靠於或把重物掛於把手上。

Do not lean on or hang loads on the handle.



- 抱放孩子時，手推車可能因不穩定而翻倒，請用一隻手支持。Please support the stroller when seating and unseating the child to avoid tipping over.

- 切勿承載超過一名幼兒，或讓幼兒坐在座椅以外的地方。Never carry more than one child in the stroller. Do not allow a child to ride or sit on areas other than the seat.

- 使用前，或是換轉把手方向後，請確認靠近推車者一方的輪鎖上的三角形符號，正正相對著方向輪鎖，而方向輪亦已經固定。

After switching the handle position, before use, please check and make sure the swivel locks on the parents side are in the proper direction, with the triangle mark facing the swivel lock and the swivels are engaged.

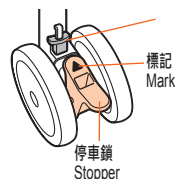

**警告WARNING** 錯誤使用，可能引致重大事故的發生。 Misuse of the product may cause serious accidents.

- 當您已切換至正常使用或正常把手，請務必將腳輪鎖桿提起解除腳輪。  
若不解除鎖定，這可能使腳輪不能自動換轉。

When you switched the normal use or handle, please make sure to raise the casters lock lever to release the caster. If you do not release the lock, there is a possibility that the caster is not automatically switched.

轉換把手時，必須解除轉向輪鎖。(共4處)。

When reversing the handle, please release swivel lock levers (total 4 places)

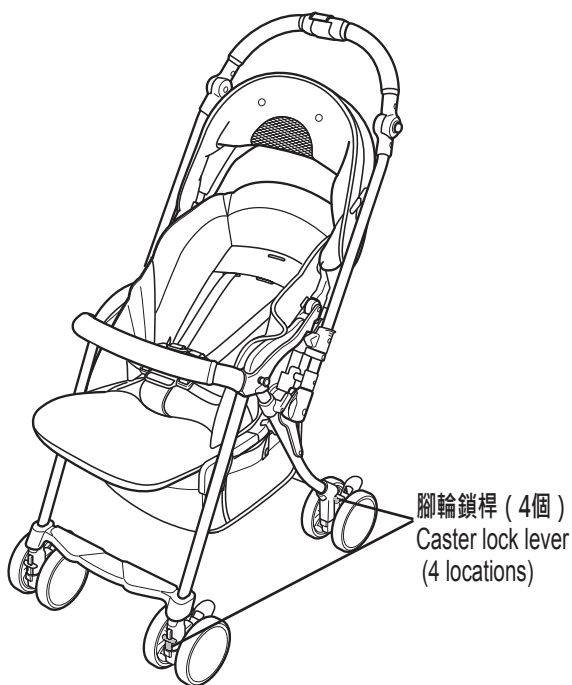
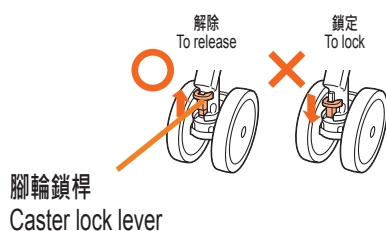

**警告WARNING** 錯誤使用，可能引致重大事故的發生。 Misuse of the product may cause serious accidents.

**推車傾倒，孩子跌落的危險**  
Tipping over of the stroller and causing the child to fall off.

- 請注意有關夾著可拆卸的材片等。  
當打開及收摺手推車時，請注意有關可拆卸的材片、安全帶、毯子、玩具等在手推車體上未被夾著。  
若收摺嬰兒車不將鎖鎖上，手推車可能因腳輪鎖未自動鎖定而下墜。

Be caution the pinching of detachable sheet etc.

Please note that detachable sheet, seat belt, blanket, toys, etc not being pinched in the stroller body at the time of opening and closing the stroller.

If you fold the stroller without applying the lock, the stroller may fall because of the caster not being locked automatically.

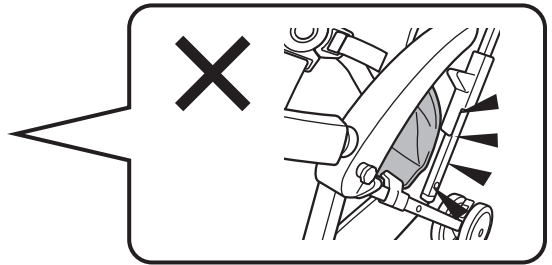

**推車未被固定，而發生傾倒**  
Stroller not yet fixed and causing tipping over.

- 請勿過分信賴停車鎖。  
Do not over-rely on the stoppers.

● 即使已經鎖上停車鎖，手推車也有可能意外滑動或翻倒。  
Stroller may move suddenly or tip over even when stoppers are engaged.



- 切勿讓幼兒單獨坐在車上。  
Never leave the child unattended.



- 即使幼兒不在車上，也不可將手推車隨意放在路旁或斜坡等危險地方。

Do not leave baby stroller at road side or slope even when it is not in use.



## 避免引致幼兒身體受傷的事項 To avoid child's body to be hurt

- 開關手推車或調節座墊時要注意四周旁人及小孩，以免夾傷手指。  
Be careful of those around you to avoid pinching their fingers when you are opening or folding the stroller or adjusting the seat angle.
- 在折疊以及打開車篷時，請注意不要夾到幼兒的手指。  
When you open and fold the canopy, be careful not to pinch baby's finger.
- 轉換把手方向時，請小心確認幼兒手足沒有放在扶手上，以免夾傷。  
Be careful not to pinch the baby's hands or feet when reversing the handle.
- 請勿使用未安裝椅墊的手推車，以免幼兒手腳等意外夾在手推車上的縫隙當中。  
Do not use a stroller without a seat cushion properly attached. Otherwise the child's hands or feet may be pinched in gaps on stroller.
- 當幼兒的足部接觸到車輪或地面時，請停止使用本產品，以免幼兒足部受傷。  
When child's legs are long enough to touch on the wheels or ground, please stop using the product.

## 警告WARNING

錯誤操作有可能引至受傷，又或是對產品造成損壞。  
Misuse may lead to injury of child or cause damage to the product.

- 不要用作乘坐孩子以外的用途，指定功能以外的使用可能會有損壞的危險。  
Please do not use the stroller in whatever purposes other than seating a baby. Failure to comply may result in damage of the stroller.
- 不要讓孩子操作手推車，可能有翻倒等意想不到的事故發生。  
Do not allow children to open or fold the stroller in order to avoid tipping over or unexpected accidents.
- 不要用力拉扯/轉動前護欄，有破損可能。  
Do not pull or twist the front guard hardly. Otherwise the stroller may be damaged.
- 不要在前扶手上加載過大的力，和不必地拉長前扶手。  
Do not forcibly press down or elongate the front guard to avoid any damage.
- 孩子乘坐時，安全帶裝著好後，請確認安全帶沒有鬆弛等現象，否則孩子可能有滑出和跌落的危險。  
Make sure the safety belt is fastened. Check if the belt fits properly. Or the child may fall off from the stroller.
- 還不能自己坐立的孩子，請在靠背平躺位置使用。(參考第18頁)  
Please apply a reclined seat to baby who cannot sit straight by itself. (Please refer to page 18.)
- 當幼兒頭部抵住椅墊靠頭部的壁面時，請把靠背儘量拉起至合適角度，令頭部不會抵住靠背為止。  
When the child's head is becoming too tight against the headrest of seat pad, please raise the backrest as much as possible so that the headrest won't press against child's head.
- 孩子的頭部會碰到頭靠的擋頭時，請不要使用平躺的靠背。  
Do not use the most reclined angle if the baby's head touches at the head rest.
- 成人不要在推車上乘坐和載入過大的重量，可能造成損壞和故障。  
Do not let adult to add load on the stroller to avoid any damage to it.
- 不要奔跑地推行推車。奔跑時可能使轉向輪運動惡化，造成翻倒等事故發生。  
When pushing the stroller, please walk slowly to avoid any damage to the stroller swivel wheels or any tipping over happened.
- 不要加裝任何如鐵棒等的物件用於該孩子乘坐的目的，可能會造成推車損壞。  
Do not attach other accessory like iron board to the main body for child sitting purpose. Otherwise damage may be caused to stroller.
- 儲物籃請勿載重超過5公斤，以免引致損壞。  
**Do not load more than 5kg into the basket.**
- 切換把手方向時，請把方向輪鎖全部開放，否則不僅會令手推車變得難推，更加會對手推車造成損壞。  
Make sure to release all swivels when switching the handle direction. Otherwise the stroller may become dragged and damage may be caused to the stroller.
- 請不要擅自改造，拆解推車，因為這可能產生危險。  
Do not remodel or restructure the stroller by yourself as this may be causing hazard.
- 不要在積雪或凍結的路面等容易滑倒的地方使用，推車和推行者也容易滑倒。  
Do not use the stroller in snowy days or on frozen roadways to avoid the stroller or guardian from slipping.
- 不要在強風的時候使用，推車有被吹跑和翻倒的危險。  
Do not use the stroller in windy days to avoid the stroller or guardian from falling on the ground or being pushed away by the wind.
- 打雷的時候不要外出使用，有被雷擊的可能。  
Do not use stroller in lightening days to avoid thunder stroke.
- 在夏季晴空烈日下，由於路面的影響使推車內溫度升高，請避免長時間使用。  
Avoid continuous outdoor usage particularly during day time in summer.
- 不要在近火源或高溫處使用和保管推車可能造成故障和變形。  
Do not store the stroller under high temperature or near fire to avoid deformation.
- 推動手推車時請小心路上凹陷的地方，以免前輪意外陷進溝內令手推車翻倒。  
When pushing the stroller, please pay attention to any hole or track on the ground to avoid the front wheel from accidentally getting jammed and tipping over.
- 請定期檢查所有螺絲是否上緊。  
Check regularly that all screws, bolts and nuts are engaged tightly.
- 跨越火車軌和汽車道的十字道口等時，請提高前輪跨越間隙，以免前輪意外卡在溝內。  
Lift front wheels and pay particular attention to gaps or ditch when crossing rail road.
- 請勿把手推車橫向置放，或者在上面置放重物，以免令手推車變形。  
Do not place the stroller horizontally or place load on of it. Otherwise the stroller may become deformed.
- 直立式存放手推車時，請先將方向輪鎖往內鎖定，然後鎖上輪鎖，否則會令手推車較易翻倒。  
When storing the stroller vertically, please make sure to lock the swivels toward the inner side. Otherwise the stroller may have chance to tip.
- 禁止長時間使用  
長時間連續使用，可能造成孩子負擔，所以平躺狀態時使用控制在2小時內，坐立時控制在1小時內。  
No continuous use for a long period  
Continuous use for a long period of time may exhaust baby. No continuous use of more than 2 hours for a baby seated in a reclined seat and 1 hour in an upright seat.
- 不要在公共車上使用  
本產品並不是設計用來在公共車上使用的，遇急變向或急剎車時可能造成翻倒等事故。  
Do not use the stroller on public vehicles.  
This product is not designed to use on public vehicle. The stroller may be tipped over when come across the sudden brake or turning of the vehicle.
- 在軌道地鐵上使用  
本產品並不是設計用來在軌道地鐵上使用的，遇急變向或急剎車時可能造成翻倒等事故，使用者自願承擔責任及風險使用時，務必啟動剎車防止翻倒。  
For use on trains  
This product is not designed to be used on trains. When user attempts to use the product at his/her own risk, please lock stoppers in case of sudden brake or turning. Otherwise stroller may fall off.

部件名稱 (請詳細閱讀本章，然後正確安裝手推車)  
Name of parts (Please read this page carefully before installation)

大型車篷  
Extra large canopy

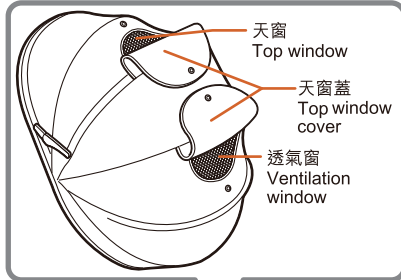

座墊的中央部分  
Center of the seat cushion

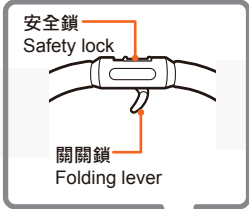
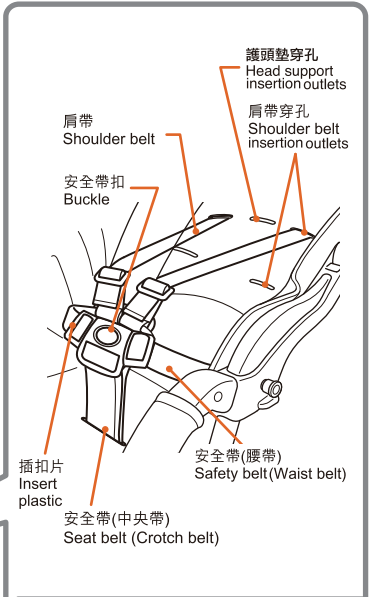

護頭板(活動式頭墊)  
Headrest (Movable headguard)

車篷支杆  
Canopy lever

椅墊  
Seat cushion

把手  
Handle

側扶手  
Armrest

前護欄鬆脫鎖  
(內外側)  
Front guard buttons  
(Inner/Outer)

前護欄套  
Front guard cover

前護欄  
Front guard

座墊加長杆  
Leg support bars

盛物籃  
Basket

踏腳板  
Foot step

轉向輪鎖  
Swivel  
wheel locks

停車鎖  
Stopper  
前後左右(共四處)  
Front and rear  
wheels  
(total 4 places)

懷抱型座墊  
Dacco cushion



頭靠墊  
Head support



護背連臀墊  
Body & Hip Support

[背部]  
[Back]

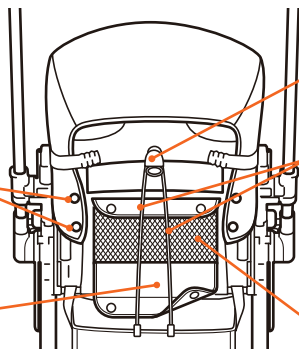

透氣百頁窗  
Air-through  
louver

透氣百頁窗  
Air-through  
louver

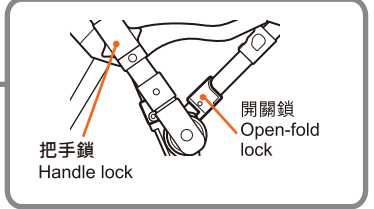



## 打開手推車 Opening the stroller

### 警告 WARNING

- 使用前必須確認折疊開關處於鎖定狀態，否則有突然折疊的危險。(參照右圖)

Make sure the open-fold lock is engaged completely before use.

- 打開嬰兒手推車不要讓他人接觸，以免意外夾傷。

Open the baby stroller in clear area.

- 除開折手推車外，請勿觸碰開關鎖。

Please do not touch the folding lever except when folding the stroller.

- 使用前，或是換轉把手方向後，請確認靠近推車者一方的輪鎖上的三角形符號，正正相對著方向輪鎖，而方向輪亦已經固定。否則，手推車或會有翻倒的危險，令幼兒受傷。

After switching the handle position, before use, please check and make sure the swivel locks on the parents side are in the proper direction, with the triangle mark facing the swivel lock and the swivels are engaged. Otherwise the stroller may have chance to tip and endanger the child.

鎖定位置 (使用時) :

開關鎖於下方，其間沒有空隙。

Locked position (while in use) :  
Open-fold locks are secured and there is no space in between.



未鎖定位置:

開關鎖於上方，其間留有空隙。

Unlocked position; the  
Open-fold locks are lifted and there is space in between.

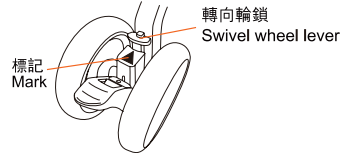

### 注意 CAUTION

- 不要讓孩子操作嬰兒手推車，可能造成手推車翻倒等危險情況。

Do not let children operate the baby stroller, this may cause the tipping over of the stroller.

- 在提起手推車的狀態下握緊開關鎖解除鎖定，會對手推車造成損壞。

Do not squeeze the folding lever when lifting the stroller. Otherwise damage may be caused to the folding mechanism.

本推車可以一次折疊。

This stroller can be folded by one step.

1. 將把手上的安全鎖部分向箭頭方向滑動並保持可解除安全鎖。

Slide the safety lock in demonstrated direction to release the safety lock and keep it at almost right position.

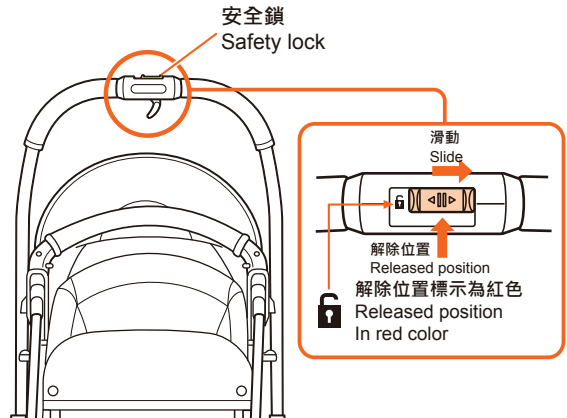

2. 站在手推車的後面。  
Standing behind the stroller.

1. 一邊握住折疊開關，一邊提起推把  
Lift the stroller upwards while grip the folding lever.

2. 將把手往箭咀方向拉動，打開手推車。  
Pull down the handle to open the stroller as demonstrated direction.

手推車完全打開。  
The stroller is fully opened.

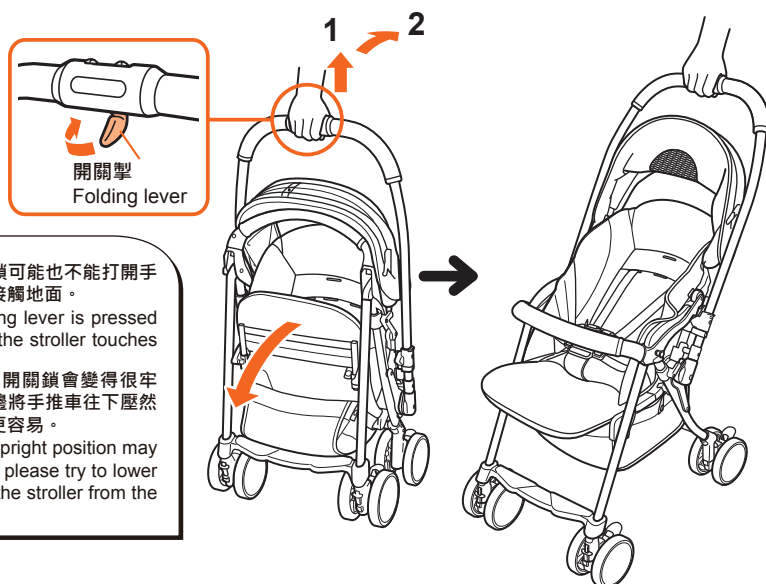

- 在提起手推車的狀態下，即使按開關鎖可能也不能打開手推車。操作開關鎖時，請確保手推車接觸地面。  
The stroller may not open if the folding lever is pressed while the stroller is lifted. Make sure the stroller touches at the ground during operation.
- 在靠背拉起的狀態下收起手推車時，開關鎖會變得很牢固。這時可以將靠背放低，又或者一邊將手推車往下壓然後才收緊開關鎖打開手推車，令打開更容易。  
A folded stroller with the backrest in upright position may be a little stiff to unfold. In such case, please try to lower the backrest first or slightly press on the stroller from the top before unfolding it.

## 警告 WARNING

- 轉換把手方向時，請小心確認幼兒手足沒有放在扶手上，以免夾傷。

Be careful not to pinch the baby's hands or feet which may be put on its armrest when reversing the handle.

- 切換把手方向時，請把方向輪鎖全部開放，否則會令靠近推車者一方的方向輪未能鎖定，而令手推車翻倒及幼兒受傷。(參照圖A)

When switching the handle position, please make sure to release all swivels first. Otherwise the swivel at the pushing side may not be engaged in the correct position and cause the stroller to tip and endanger the child. (Refer to picture A)

- 請勿在斜坡上轉換把手方向，否則會令方向輪未能鎖定，而令手推車翻倒及幼兒受傷。

Do not switch the handle direction when stroller is on a slope. Otherwise the swivel may not be engaged in the correct position and cause the stroller to tip and endanger the child.

- 使用前，或是換轉把手方向後，請確認靠近推車者一方的輪鎖上的三角形符號，正正相對著方向輪鎖，而方向輪亦已經固定。否則，手推車或會有翻倒的危險，令幼兒受傷。(參照圖B)

After switching the handle position, before use, please check and make sure the swivel locks on the parents side are in the proper direction, with the triangle mark facing the swivel lock and the swivels are engaged. Otherwise the stroller may have chance to tip and endanger the child.

(Refer to picture B)

- 請勿在轉換把手方向時移動手推車，否則會令方向輪未能鎖定，而令手推車翻倒及幼兒受傷。

Do not push the stroller when switching the handle position. Otherwise the swivel may not be engaged in the correct position and cause the stroller to tip and endanger the child.

- 將把手換成前向使用狀態時，請確認左右兩端後腳管上的活動鎖已經處於下方位置，否則會令方向輪鬆脫，而令手推車翻倒及幼兒受傷。(參照圖C)

Make sure the left and right sliders on the rear leg tubes are in the lower position and engaged, when switching the handle to the forward facing position. Otherwise the swivel may have chance to slip accidentally and cause the stroller to tip and endanger the child.

- 前向使用狀態時，請勿觸碰後腳管上的活動鎖，否則會令方向輪鬆脫，而令手推車翻倒及幼兒受傷。

In forward facing position, please do not touch at the sliders on the rear leg tubes. Otherwise the swivel may have chance to slip accidentally and cause the stroller to tip and endanger the child.

- 前向使用時，請勿觸碰後腳管的滑塊。轉向輪鎖或會鬆脫，手推車有可能因而翻倒而導致孩子跌落。

When using forward facing mode, please do not touch the slider on the rear pipe or the swivel lock may be released and cause the stroller tipping over and child falling off.

圖A 向上撥轉向輪鎖  
Diagram A Lift up the swivel lock lever

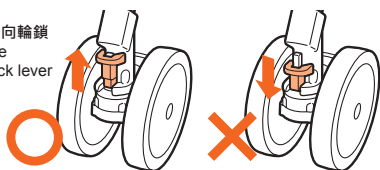

圖C 請確認左右兩端後腳管上的活動鎖已經處於下方位置。  
Diagram C Check that the left and right sliders on the rear leg tubes are in lower position and are engaged.

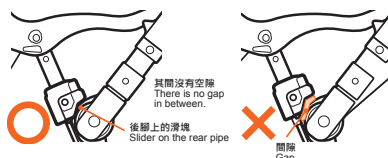

圖B 請確認靠近推車者一方的輪鎖上的三角形符號，正正相對著方向輪鎖，而方向輪亦已經固定。

Please check and make sure the triangle marks on the swivel at the pushing side are facing the swivel locks correctly and the swivels are already engaged.

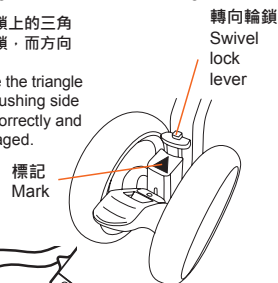

## 注意 CAUTION

- 請勿一邊推動手推車，一邊轉換把手方向，以免引致危險。

Do not reverse handle while pushing the stroller.

- 轉換把手方向時，請先從前方確認幼兒狀況後才開始操作。

Check the baby's situation from the front side before reversing the handle.

- 換向時，請將推把杆角度回復到原來的直線狀態。

When reversing the handle, please return the handle to the original straight line situation.

- 關開手推車時，切勿操作把手鎖，以免造成本推車損壞。

Do not touch at the handle lock when folding or unfolding the stroller. Otherwise damage may be caused to the stroller.

- 轉換把手方向時，必須確認四處轉向輪鎖已經解除。如在沒有解除的狀態下轉換把手，不僅會令推行困難，更有可能造成破損。

Please make sure the swivel lock levers (total 4 places) are released before reversing the handle. Otherwise, the stroller will be difficult to push and the stroller may be damaged.

- 本產品設計上，不論在前向或後向使用狀態，在轉換把手後，靠近推車者一方的方向輪會自動鎖上，令轉向輪永遠在前方。  
This product is designed so that the swivels at the pushing side are always locked no matter which direction the handle is at. The swivels are always at the front side.

## 轉換把手方向 Reversing the handle

1. 請確認4處轉向輪鎖已全部解除。  
Please make sure the swivel lock levers (total 4 places) are released.

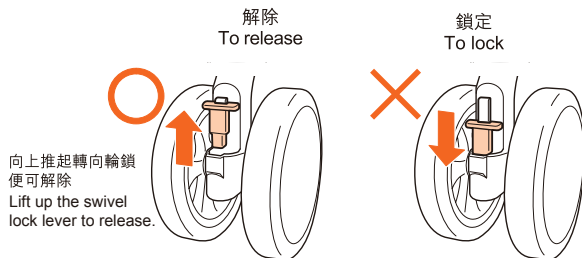

2. 將左右兩方的把手鎖同時拉起作解除。  
Lift and release the handle lock on both sides.

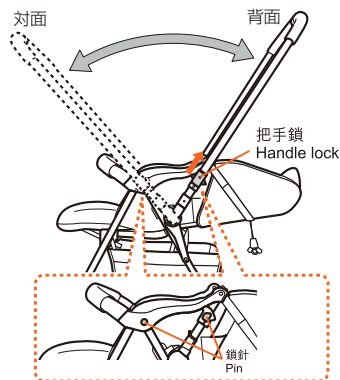

3. 轉換把手方向，直至把手鎖重新鎖上為止。  
請確認靠近推車者一方的方向輪會改變方向，輪鎖上的三角形符號，正正相對著方向輪鎖，而方向輪亦已經固定。  
Reverse the handle until the handle lock is secured again.  
Check that the swivels at the pushing side change in a way such that the triangle marks on the swivel at the pushing side are facing the swivel locks correctly and the swivels are already engaged.

4. 將手推車推行一段距離以確認左右的轉向輪方向已改變並可以見到標記。標記必須向着轉向輪鎖並確認已鎖定。  
Please push the stroller in a short distance to ensure the direction of the swivel wheel has been changed and the mark can be seen. The mark should be facing the swivel lock lever and ensure it is locked properly.

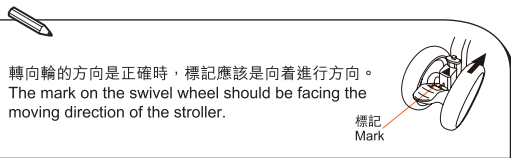
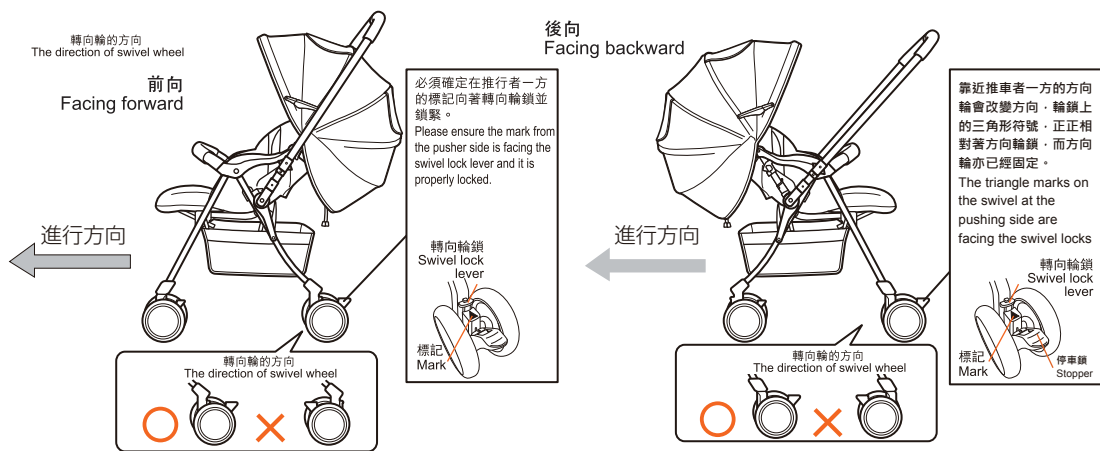

改變把手方向後，請確認以下事項。  
Check the followings after the operation.

- ① 請確認把手鎖已經重新鎖上。  
The handle lock is resumed to locked position again.
- ② 輕輕上下搖動把手，確認已經固定。  
Move the handle back and forth to check if it is secured.
- ③ 在改變把手方向後，請注意左右後腳的滑塊是否完全落下。  
(請參考第8頁警告欄內的圖C。)  
After reversing the handle, please make sure the slider on the left and right rear pipe is properly locked. (Please refer to the diagram C on the warning column of page 8.)
- ④ 方向輪的方向正確的話，輪鎖上的三角形符號應該會指向前進方向。  
The triangle marks should be facing the pushing direction if the swivels are locked at the correct position.

## 注意 CAUTION

- 與幼兒面對面狀態時，由於推把的角度可能會造成越過臺階困難。

這種狀況下，可以採取如腳踩踏腳板使前輪翹起，使用者先上臺階後再提上推車的方法越過臺階。

In case of using the face to face mode, and after changing angle of the handle grip, it may be causing difficulties of pushing the stroller across the stairs. In this case, pusher can put the foot onto the footrest and lift up the front wheels to go over the steps first and then lift up the stroller.

## 使用轉向輪 Using the swivel wheels

- 在平坦路面使用，可使手推車更順暢推動及轉向容易。  
It is recommended to release all the swivel wheel locks when use on flat surface for easy strolling.
- 在不平路面推行時，建議鎖上轉向輪鎖。  
It is recommended to lock all the swivel wheel locks when using on the rough surface.

### 使用轉向功能時 To use the swivel wheel

向上推起轉向輪鎖(左右)以解除。  
(根據進行方向)  
Lift the swivel wheel lock levers(left and right)  
to release. (according to the moving direction).

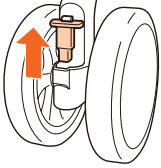

靠近推車者一方的方向輪會自動鎖上。  
The swivels at the pushing side will be engaged.



靠近推車者一方的方向輪會自動鎖上，不能使用手動方向輪鎖。  
The swivels at the pushing side will be engaged. Manual swivel lock cannot be used.

### 不使用轉向功能 Swivel wheel not in use

請按下和推行者同一方向的2處轉向輪鎖以鎖定。  
Press down the swivel lock lever (the ones at the same direction of the user) to lock.

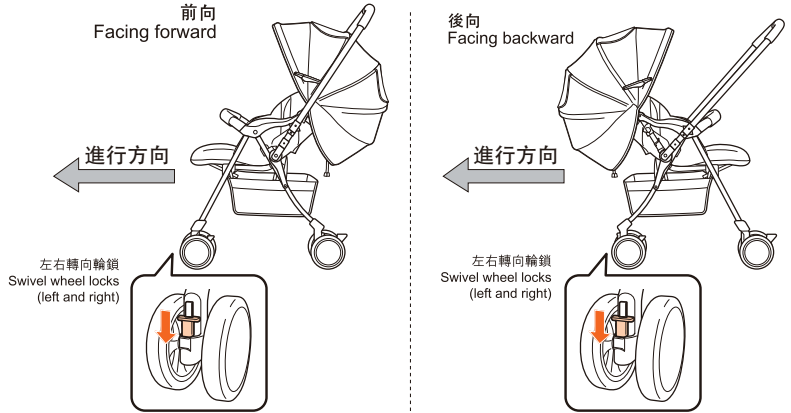

## 停車鎖的使用方法 Using the stoppers

### 警告 WARNING

- 不論有否乘載幼兒，停車時勿過分信賴停車鎖的性能。  
Do not rely too much on the stoppers even when the stroller is parked empty.
- 即使已使用停車鎖，如載有嬰孩，看顧者也不要離開手推車，以防任何危險發生。此外，停車鎖應左右兩方同時使

用，以免意外滑動或翻倒。

Even with both stoppers engaged, always stay close to the stroller when it is carrying a child. Make sure to engage both sides of the stoppers to avoid sudden movement or tipping over.

### 注意 CAUTION

- 無論車內是否載有幼兒，也須經常按下停車鎖。  
Even when empty, always engage both stoppers since the stroller may suddenly move.

停泊推車時，必須啟動停車鎖。  
Make sure the stoppers are engaged when parking the stroller.

### 鎖定停車鎖 Lock the stoppers

1. 壓下左右車輪的停車鎖。  
To lock the wheels, press the stoppers down which are located at rear wheels on both left and right sides.
2. 輕輕前後推動推車，確認剎車已鎖定。  
Try to push the stroller back and forth slightly to ensure that the stoppers are properly engaged.

### 解開停車鎖 Release the stoppers

- 將停車鎖往上撥即可解除。  
Lift the stopper to unlock.

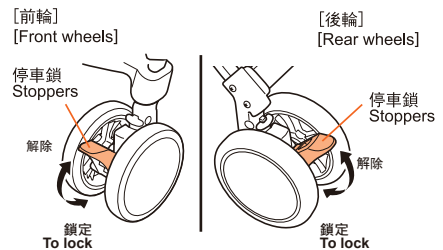

## 警告 WARNING

- 乘載幼兒必須繫上安全帶。前護欄不能防止幼兒從座椅上站起來。  
Make sure to use the seat belt when the child is seated. The front guard is not designed to prevent the child from standing up.
- 不要讓幼兒操作前護欄以免其意外跌倒。  
Do not let the child operate the front guard. It may make the child to fall off from the stroller.
- 請勿手執前護欄來舉起手推車，以免發生危險。  
Do not lift stroller by holding front guard or danger of sliding down will occur .

## 注意 CAUTION

- 請勿手執打開的前護欄來拖動手推車。  
Do not get hold of an opened front guard to pull the baby stroller.
- 請勿過度按壓前護欄，以免損壞。  
Do not forcibly press on the front guard to avoid damage.

抱放孩子時，可打開前護欄，不會纏絆腳部，方便抱放。

Releasing the front guard would make it more convenient for seating and unseating baby and to avoid trapping the legs at the same time.

### 打開前護欄 Open the front guard

1. 如箭頭方向按下前護欄鬆脫掣。  
Press and hold the button at the end of the front guard as illustrated.
2. 抽起前護欄。  
Detach the front guard.

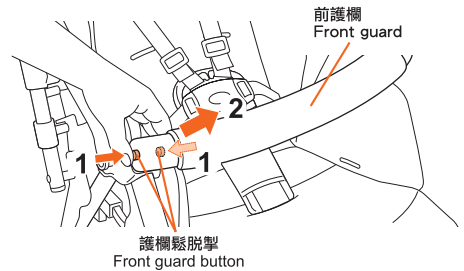

前護欄能開合的是正面左側的連接點  
The front guard can only be released and closed at the left side's conjunction from front view.

### 安裝前護欄 Attach the front guard

要鎖上護欄時，請先將護欄提起，照準末端突起部份，然後插入安裝。

To attach front guard, lift and plug into the projected part at the end of the armrest.

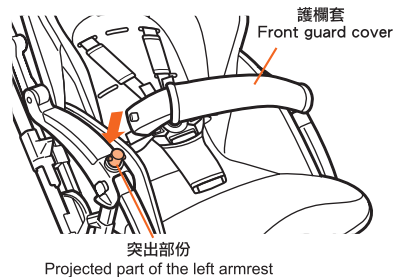

## 車篷使用方法 Using the canopy

### 警告 WARNING

在折疊以及打開車篷時，請注意不要夾到幼兒的手指。  
When you open and fold the canopy, be careful not to pinch baby's finger.

- 即使安裝了車篷，推車也可以被折疊。折疊時，必須折疊車篷，並收納在後側。 There is no need to detach canopy before folding stroller. However, canopy must be folded to the back.
- 車篷安裝方法請參見第24頁。 Refer to pg. 24 for how to install and detach canopy.

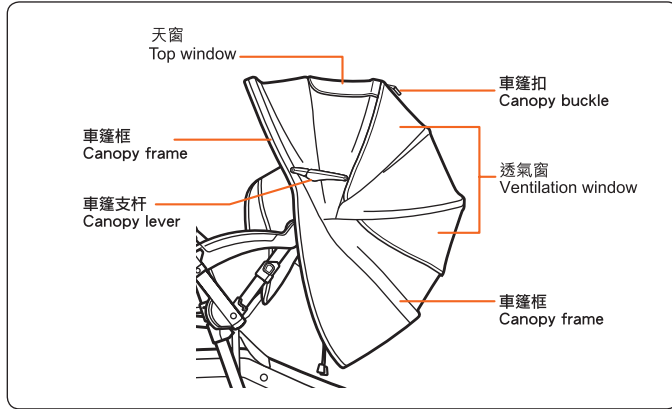

### 調節車篷大小 Adjust the covering size of canopy

#### 大車篷使用時 Using in big size

- 1 拿著前後車篷車架然後將車篷往前方翻開。  
Grab the front and back canopy frame and release the canopy to biggest coverage.
- 2 按下左右兩邊車篷支杆。  
Press on the left and right canopy levers.

#### 小車篷使用時 Using in small size

展開車篷後，將車篷框的後部向上推。  
After having extended the canopy to full coverage, push up the frame of the canopy back.

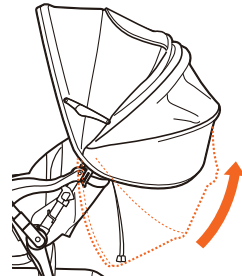
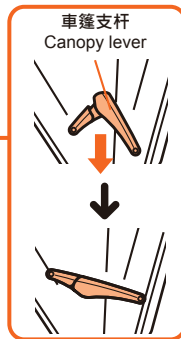
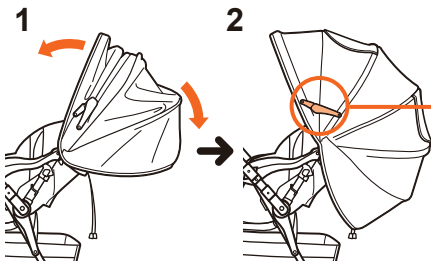

### 將車篷作太陽擋使用時 When using canopy as sunshade

- 幼兒在睡覺時，又或是太陽角度較低時，可以作為密封式太陽擋使用。 When child is sleeping or when the sun is shining at a low angle, the canopy can be used in full cover position.

在最大覆蓋的狀態下，兩手拿著太陽擋的根部，然後往前方轉動。聽到「咔嚓」一聲表示已經鎖定。  
在合適位置固定太陽擋。  
在太陽擋前方看，確認左右兩邊位置相同。  
Hold at the canopy hinge when the canopy is at its largest position and rotate it to the right position. It clicks into place automatically.  
Stop rotating when it reaches the right position.  
Look at the canopy from the front side ensuring the left and right side are at the same position.

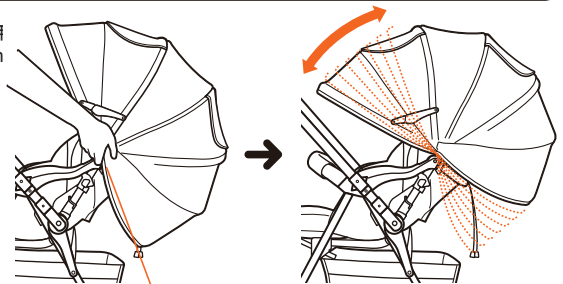

用手握住車篷裝飾條底端  
Hold left and right ends of the canopy frame

## 收納車篷 Folding up the canopy

拉起左右兩旁的車篷支杆，將車篷往後翻起。  
Lift the canopy levers and fold the canopy backward.

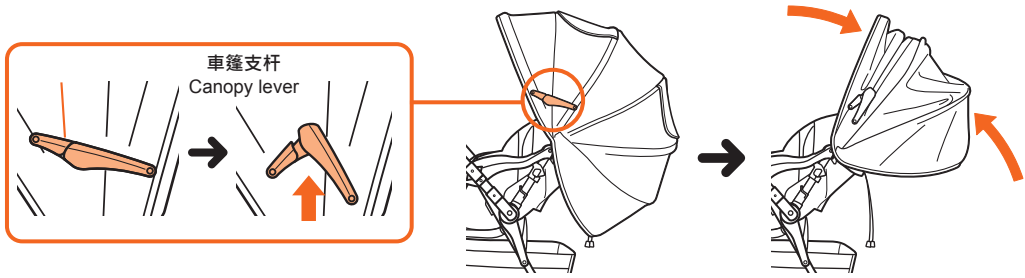

## 車篷頂窗打開方法 Using the top window

打開透氣窗蓋布，可以觀察孩子的情況。  
You may look at the child with the top window opened.

### 打開天窗 To open the top window

將鈕扣打開。  
Undo the snaps.

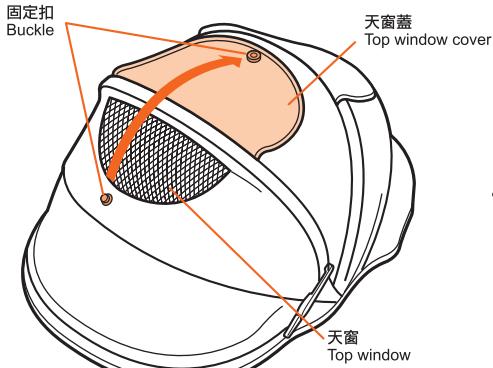

前面  
front

### 關閉天窗 To close the top window

將車篷上的鈕釦重新扣上。  
Secure the snaps on top.

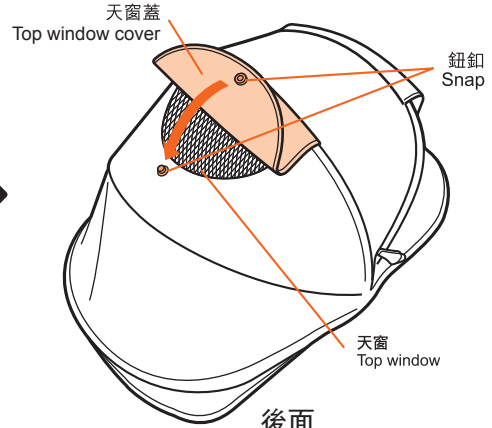

後面  
back



使用靠背透氣窗的方法  
Using the air through system (backrest ventilation window)

透過使用底座的靠背通風窗，幼兒會舒適地度過炎熱或悶熱的天氣。

Through the use of backrest ventilation window at the base, child keeps comfortable during in hot or muggy weather.

打開靠背透氣窗 Open the air through system (backrest ventilation window)

1. 解開背部透氣窗蓋布上左右兩邊的刺黏固定貼。  
Release the air through cover by Velcro fasteners at the back of upper part pocket.

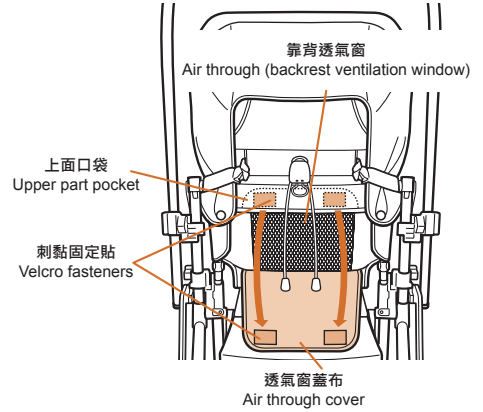

2. 將透氣窗蓋布向內捲起及收藏在下面口袋內。  
Roll up inward and store the air through cover to the lower part pocket.

不使用靠背透氣窗時，把透氣窗蓋布的刺黏固定貼貼上。  
Close up the air through cover by Velcro fasteners when not using the air through system (backrest ventilation window).

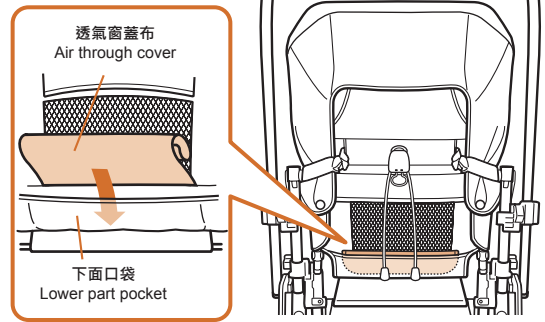

使用腿部支援杆  
Using the leg support bar

使用腿部支援杆，可以使幼兒睡覺時姿勢更舒適。

Apply the leg support bars for better comfort when child is asleep.

⚠ 注意 CAUTION

- 乘載嬰孩或幼兒時請確保已用鈕扣把椅墊和腿部加長杆扣上，否則可能導致嬰幼兒受傷。  
Make sure to snap the seat cushion onto the leg support bars. Otherwise it may make the baby hurt.

1. 提起椅墊，將座椅下的腿部支援杆抽出。  
Lift the seat cushion and pull out the leg support bars from the seat base
2. 蓋上椅墊，再將鈕扣扣上。  
Snap the seat cushion onto the leg support bars.

收起腿部支援杆時 To store the leg support bars

解除鈕釦，再將腿部支援杆推回座椅底部。  
Release the snaps and push the bars back to the seat base.

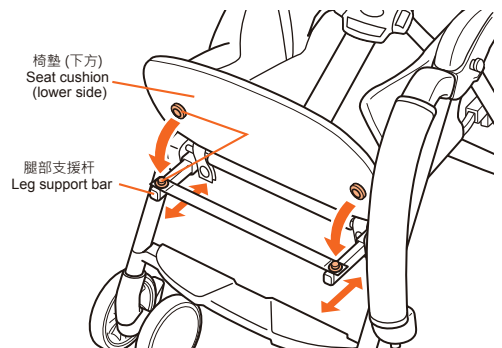

## 使用腿部支援杆 Using the leg support bars

使用腿部支援杆，可以使幼兒睡覺時姿勢更舒適。  
Apply the leg support bars for better comfort when child is asleep.

### ⚠ 注意 CAUTION

- 乘載幼兒請確保已用鈕扣把椅墊和腿部支援杆扣上。  
Make sure to snap the seat cushion onto the leg support bars.  
Otherwise it may make the baby hurt.

1. 提起椅墊，將座椅下的腿部支援杆抽出。  
Lift the seat cushion and pull out the leg support bars from the seat base.
2. 蓋上椅墊，再將鈕扣扣上。  
Snap the seat cushion onto the leg support bars.

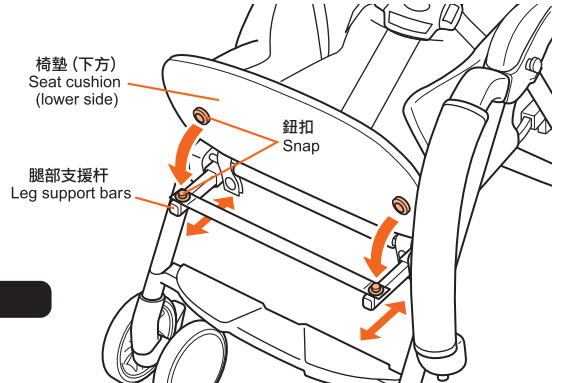

#### 收起腿部支援杆時 To store the leg support bars

解除鈕扣，再將腿部支援杆推回座椅底部。  
Release the snaps and push the bars back to the seat base.

## 拆除護欄套 Detaching the front guard cover

1. 按下護欄按鈕，將護欄開放。  
Press and hold on the front guard buttons and release the front guard.
2. 從護欄上取出護欄套。  
Detach the front guard cover from the front guard.

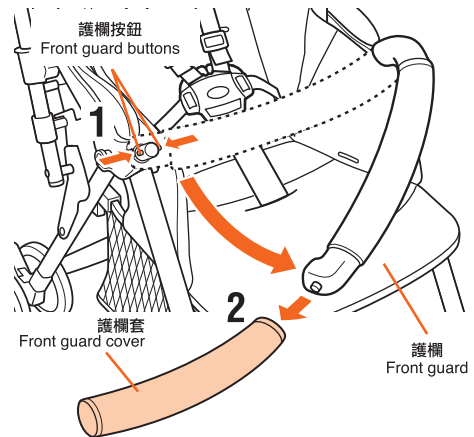

讓幼兒使用手推車時，建議裝上護欄套使用。  
It is recommended to attach front guard cover to use.

## 安全帶(中央帶, 腰帶, 肩帶)的使用方法 Using the seat belt (crotch belt, waist belt, shoulder belt)

### 警告 WARNING

- 有幼兒乘坐時，必須使用安全帶。不使用安全帶，或束縛不完全，使用中可能造成孩子跌落。  
Always use the seat belt when the child is carried in the stroller. Without using the seat belt or using it incorrectly may cause danger to the child.
- 另外即使使用了安全帶，也要十分注意幼兒從車內滑落或站立等危險情況。  
Furthermore, even if the seat belt being used, user should pay attention to the child stand up or fall off.
- 根據幼兒的身體調節安全帶長度，牢固束縛，防止滑落。  
Adjust the seat belt to fit the child, to make sure it is not too loose to avoid child being fallen off.
- 將肩帶扣在插扣片上時，請勿交叉肩帶，以免肩帶對幼兒頸部造成壓迫。  
Do not cross the shoulder belts with each other when securing the shoulder belt to the insert plastic. Otherwise excessive pressure may be caused to child's neck.

安全帶是中央帶、腰帶、肩帶的總稱。  
Seat belt here refers to the crotch belt, shoulder belt and the waist belt.

#### 安全帶束縛和脫開的方法 Attaching and releasing seat belt

##### 安裝安全帶時 To attach seat belt

1. 將肩帶扣在左右兩方插扣片上的肩帶勾上。  
Attach shoulder belts to the shoulder belt hook of the left and right insert plastics.
2. 拿起中央帶，在安全搭扣的左右插入安全插扣，聽到“咔嗒”一聲，說明已安全插入。  
Take the crotch belt and put the insert plastics into the buckle until a “Click” sound is heard.
3. 拉動中央帶，腰帶，肩帶，確認有無鬆動。  
Pull the shoulder belts and waist belts to check if it is secured.

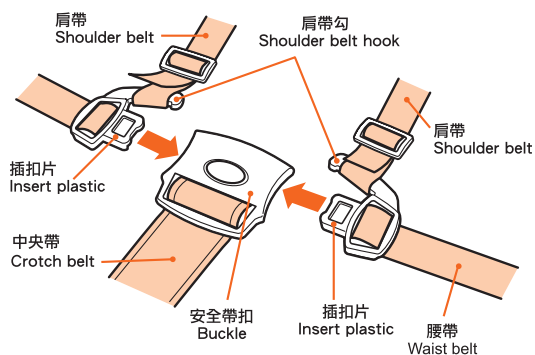

##### 解除安全帶時 To release seat belt

按下安全帶扣中央的按鈕解除。  
Press down the centre buckle button to release.

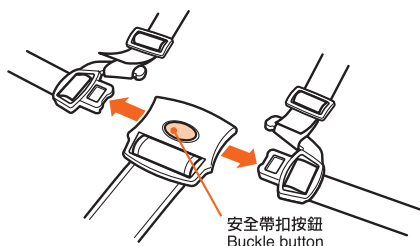

#### 束縛孩子時 Fitting the seat belt to child

1. 讓孩子坐在車內，使其肩膀左右與肩帶貼合。  
Seat the child into the stroller and fit the shoulder belts on the child's left and right shoulder.
2. 把安全插扣上的肩帶掛鉤(左右)，裝入肩帶掛扣中，將安全搭扣的左右插入安全插扣。  
Secure the left and right shoulder belts to the shoulder belt hooks and fasten the insert plastics into the centre buckle.

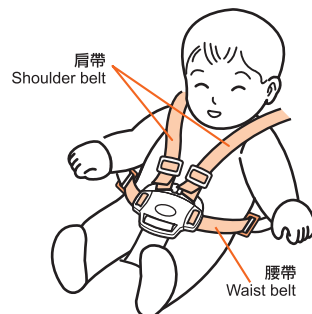

- 在低月齡孩子使用時，靠背可能經常調節角度，請選擇最下方的肩帶穿孔。  
Use the lower shoulder belt insert outlets for child who may need frequent adjustment in the seat reclining angle.
- 改變肩帶穿孔位置，請參閱第27頁“肩帶安裝方法”確實牢固地安裝。  
To adjust the shoulder belt insert outlet position, please refer to pg. 27 to be sure to tightly attach the seat belt.
- 長度調節和安全插扣脫卸時，請參閱第26頁“安全插扣安裝方法”確實牢固地安裝。  
Make sure to attach the insert plastics to the waist belt after adjusting. Refer to [Attaching to the insert plastics](p.26)
- 不完全地安裝，使用中可能有安全帶鬆脫的危險。  
Seat belt may get detached accidentally if not installed properly.
- 在插扣片難於拆除的情況下，請輪流按下安全帶扣的左右，先拆除一邊的插扣片再拆除另一邊。  
When find it difficult to release the insert plastic, please alternatively press the left and right side of the buckle, then release the insert plastic one by one.

## 安全帶調節方法 Adjusting the seat belt

### 腰帶長度調節方法 Adjusting the length of waist belt

插扣片上的腰帶穿孔  
Slots on the insert plastic

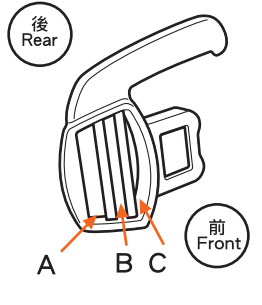

1. 從插扣的背面把腰帶穿出  
A孔。  
Pull the waist belt from the rear side to the front through outlet A.

2. 把腰帶左右拉動, 以調節腰帶長度。  
Slide the waist belt to left or right to adjust its length.

3. 把腰帶重新從插扣正面穿回A孔到背面。  
Put the waist belt from the front side to the rear through outlet A.

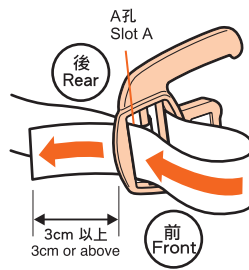
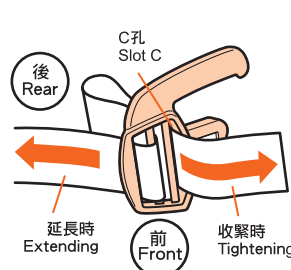
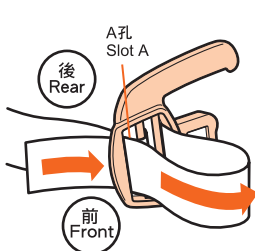

#### 遇到問題 Encounter any problems

如何調節安全帶的鬆緊度

Having questions in adjusting the seat belt

→ 在孩子和安全帶間, 以能伸進大人手指的第二關節的間隙為準。

There should be space which can accommodate second joint of adult's fingers.

#### 警告 WARNING

長度調節後, 請用力拉動安全帶扣以確認安全帶沒有鬆脫。

Please strongly pull the buckle to ensure the safety belt is secured.

腰帶的長度調節後, 腰帶的末端必須保留3cm以上。  
Make sure to leave at least 3cm at the waist belt end.

### 中央帶的使用方法

### Using the crotch belt

调节中央带长度时, 先如 ① 般将需调节部分抽出。

要延长时向 ② 方向拉, 要收紧时则向 ③ 方向拉。

Pull out the length needed to adjust to direction ①. Pull toward direction

② to extend the crotch belt and ③ to tighten the crotch belt.



中央帶是不能拆除。  
Crotch belt is not detachable.

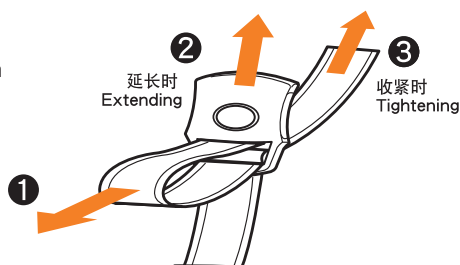

### 肩帶長度的調節方法 Adjusting the shoulder belt

① 肩帶長度調節時, 首先拉出想調節長度的帶長 ①

To adjust the shoulder belts, ① pull out the portion needed to be adjusted.

② 加長時, 向 ② 的方向拉動肩帶

Pull to direction ② to extend.

③ 縮短時, 向 ③ 的方向拉動肩帶

Direction ③ to shorten the shoulder belts.



調節扣環不能從肩帶拆下。  
Adjustment ladder cannot be detached from the shoulder belts.

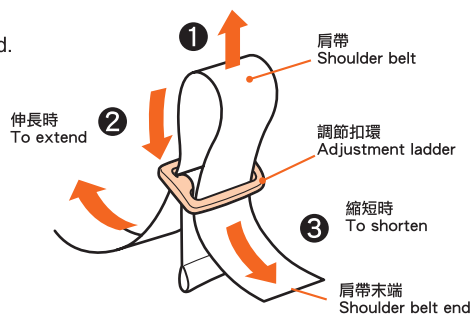

## 靠背調節方法 Adjusting the seat angle

### 警告 WARNING

- 有孩子乘坐時調節靠背角度，靠背角度加大時，必須把肩帶鬆弛後再進行調節。  
Loose the shoulder belts before lowering the seat angle with a child seated.
- 靠背角度調節後，必須重新調節安全帶長度以貼合孩子的身體。  
Adjust the length of seat belt properly after change of the seat angle.
- 調節靠背角度時，請注意周圍沒有人(特別是小孩)，以免夾傷手指。  
Please be aware of those people around you (especially child) when adjusting the sitting angle to avoid pinching their fingers.

### 注意 CAUTION

- 不要一邊推行推車，一邊調節靠背角度，非常危險  
It is extremely dangerous to adjust the seat angle when pushing the stroller. Do stop the stroller first before operation.
- 有孩子乘坐時，不要突然改變靠背角度，操作要十分注意。  
Do not suddenly change the seat angle while a child is seated.
- 有孩子乘坐時，靠背角度要調大時，操作者的另一隻手要支撐一下孩子的身體重量。  
Support the backrest with the other hand when lowering the seat angle with a child seated.
- 還不能單獨坐立的孩子請使用最平躺位置到中間位置之間的靠背角度。  
Use most reclined angle before the baby can sit straight by itself.

#### 靠背使用要領

##### Backrest angle reference

- 一個月 - 頭頸能自立  
1 month ~ neck muscle developed  
-> 靠背要調節至最平躺位置  
Fully reclined seat
- 頭頸能自立~能單獨坐立時-->  
Neck muscle developed ~ able to sit without aid  
-> 靠背要調節至最平躺位置和中間位置之間  
Fully reclined ~ partially reclined
- 可以一個人獨自坐立時  
When child can sit up unaided.  
-> 由最低至最高角度。  
靠背在最低角度時，椅墊會感覺較窄。  
只要幼兒能夠獨自坐立，儘量在靠背的中間位置使用。  
From lowest to highest position.  
The seat may feel narrow when in lowest position. As long as child can sit unaided, try to adjust the backrest to the middle to upper position to use.

#### 遇到問題? Encounter problems?

在靠背調節到平躺位置時，感覺座墊非常狹窄  
The backrest seems to become narrow in the fully reclined mode.

只限於孩子能獨自坐立時，把靠背角度調整  
Only when the child to be able to sit without aid, should the backrest to be partially reclined.

## 調節靠背角度 Reclining the backrest

- ※ 有孩子乘坐時調節靠背角度，靠背角度加大時，必須把肩帶鬆弛後再進行調節。  
While the child is carried in the stroller, the user should loosen the shoulder belt before reclining the backrest.
- ※ 有孩子乘坐時，靠背角度要調大時，操作者的另一隻手要支撐一下孩子的身體重量。  
To recline the backrest while the child is carried in the stroller, the user should support the backrest with one hand.

1. 調底座席角度時，先以單手支撐著靠背。  
Support the backrest with one hand before reclining the backrest.

2. 擋頭部自動升起  
The headrest will be lifted automatically after the backrest is reclined.  
(movable headguard)

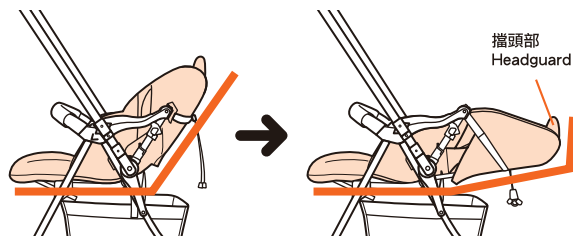
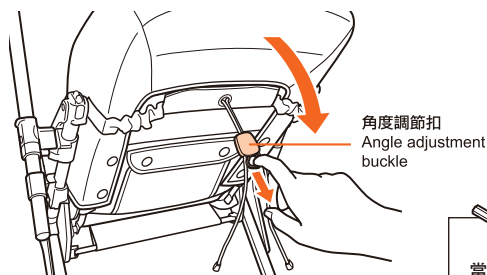

當幼兒能夠獨自坐立，而頭靠開始抵住幼兒頭部時，請將靠背調節到頭靠不會升起的角度使用。  
When child can sit up unaided and the headrest is becoming too tight, please adjust the backrest position such that the headrest will not lift.

## 調高座席角度時 Lifting the backrest

如圖般將角度調節帶往箭咀方向拉。  
Pull the angle adjustment strings to the illustratec



幼兒靠在椅背上時角度是不能調高的。  
The backrest cannot be lifted while the child is leaning against the backrest.

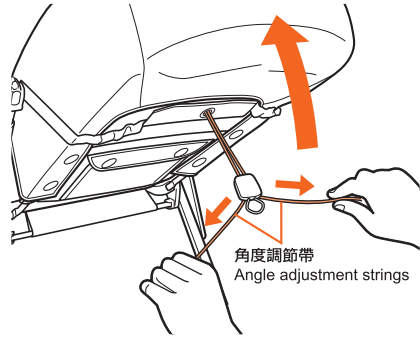

操作者一手拿著角度調節帶，另一隻手將靠背調節器滑向前方能調高靠背角度。  
Grab the adjustment strings(in bundle) by one hand, slide the angle adjustment buckle to the front with another to lift up the backrest.

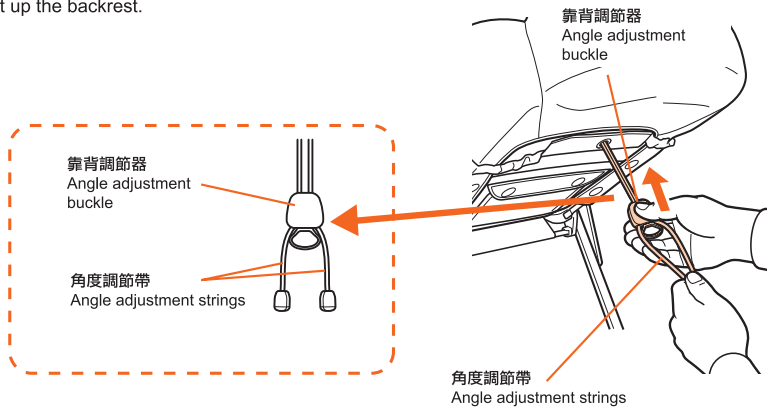

### 遇到問題? Encounter problems?

調節靠背時操作困難  
Find it difficult to operate the reclining function.

請按以下程序將調節帶伸直。  
Please follow below steps to straighten it.

調節帶出現扭曲的情況。  
The reclining belt may be twisted.

- ① 將靠背降至最低位置。  
Lower the backrest to the lowest position.
- ② 將織帶沿根部開始扭轉，把織帶上的扭紋解開。  
Release the twist at the recline belt end along the recline mechanism.

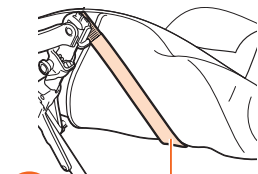

調節帶沒有扭曲  
The reclining belt is not twisted

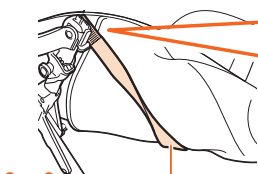

調節帶扭曲  
The reclining belt is twisted

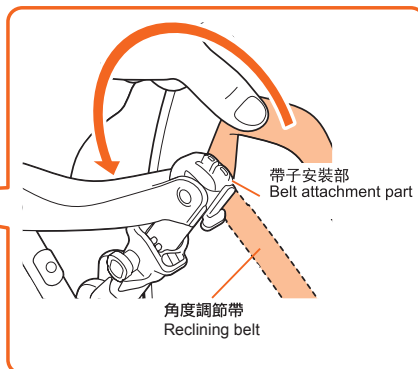

不要將靠背調節至車篷插座的前側。  
Do not lift up the backrest in front of the canopy holder.

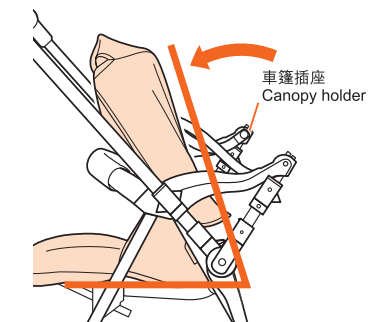

## 警告 WARNING

- 折疊手推車時，請注意周圍沒有人(特別是小孩)，以免夾傷手指。  
Please be aware of those people around you (especially children) to avoid pinching their fingers.

## 注意 CAUTION

- 收起手推車後必須鎖好扶手上的安全鎖。除開關手推車之外請勿接觸安全鎖。  
Make sure to lock the safety lock after folding up the baby stroller and keep clear from it.
- 按開關鎖前請先解除安全鎖。錯誤操作可能損壞零件。  
Make sure to release the lock before opening the stroller.
- 感覺有異物卡住時，請勿強行折疊，以免造成損壞。應先打開手推車，確認後再操作。  
When feel jammed, please do not forcibly fold the stroller
- 收起手推車前請先確認置物籃內的物品已取出。  
Make sure the basket is empty before folding up the stroller.
- 收折前請先確認車篷已完全收起，以免引致部件損壞。  
Make sure the canopy is completely folded up before folding the stroller to avoid damage of the parts.

- 即使安裝了車篷，推車也可以被折疊。折疊時，必須先折疊車篷，並收攏在後側。  
It is not necessary to detach the canopy before folding the stroller. You just need to fold the canopy backward before folding.
- 在折疊手推車前，請先解除轉向輪鎖(共4處)。  
Please release all swivel wheel locks(4pcs) before folding the stroller.

1. 把手杆回復到原來位置。  
Return the handle grip to straight position.
2. 換向把手到正面推行的位置(推把換向請參閱第11頁)。  
Handle position should be in forward facing position (refer to p.11)
3. 定向鎖定轉向輪。  
這時，如圖把轉向輪方向轉到內側。  
Lock the swivel wheel lock as illustrated position.



2. 1. 將靠背提起。  
{靠背使用方法}請參閱第21頁。  
Lift up the backrest. (refer to P.21)
2. 將車篷完全地收起。  
{車篷使用方法}請參閱第15頁。  
Fold the canopy completely. (refer to P.15)

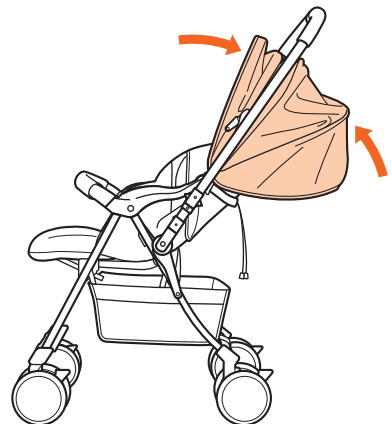

3. 依箭咀方向解除安全鎖。  
Release the safety lock in the demonstrated direction.

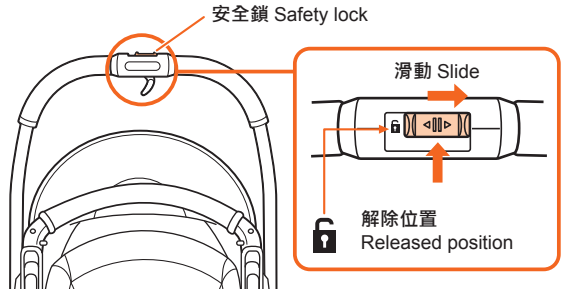

4. 一邊握住折疊按鈕，一邊提起推把杆，然後按下推把。推車被折疊起來。  
Grip the folding lever and slightly lift up the handle, then press down the handle as illustration to fold the stroller.

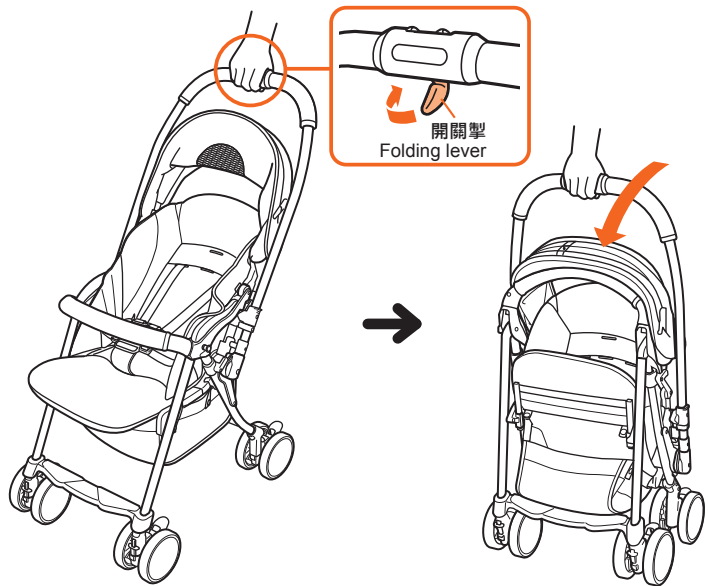



車篷的裝拆方法  
Installing and detaching the canopy

安裝車篷 To install the canopy

1. 把手置於對面位置  
詳見第11頁「轉換把手方向」  
Switch the handle to face rear.  
Refer to P.11 "Reversing the handle"
2. 詳見第20頁的「靠背調節方法」的內容  
Recline the backrest to the lowest angle.  
Refer to P.20 Adjusting the seat angle.

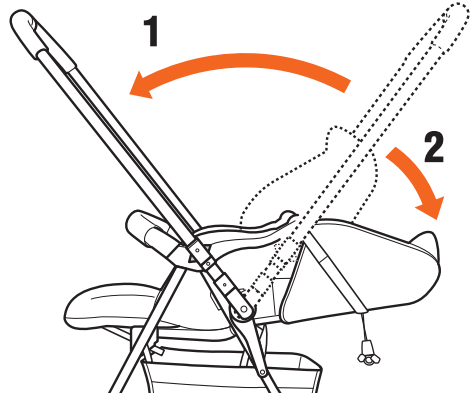

3. 確認車篷前後方向。  
Place the canopy facing the proper direction.

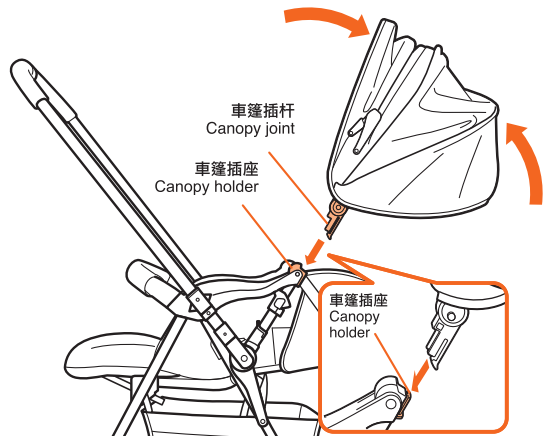

4. 然後將車篷插杆插進車身上插座之中。  
Plug the canopy joint into the canopy holder.

拆除方法 To detach the canopy

將插座下方從末端方向拉著插杆末端，慢慢將車篷拔出。  
Pull out the canopy joint and gradually pull up the canopy away from the holder.

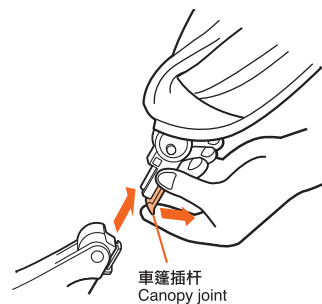

安裝盛物籃  
Installing the basket

**⚠ 注意 CAUTION**

- 不要擺放超過推薦載重量的物品，可能造成損壞。  
Do not load more than the maximum loading into the basket to avoid damage.
- 請勿盛載太尖或太大的東西，可能造成盛物籃損壞。  
Do not put things that are too sharp or too large into the basket since it may cause damage to the basket.
- 收起手推車前，請先將盛物籃內的東西拿走。  
Remove all things from the basket before folding up the stroller.

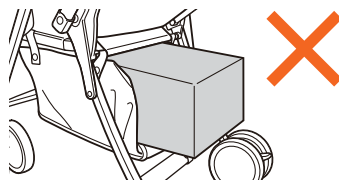

※ 物件擺放

To accommodate stuff

- 盡可能在盛物籃底部均勻擺放重量。  
Distribute load evenly inside the basket.
- 放拿物品時，可拉開盛物籃側面的拉鏈，比較方便。  
It is recommended to pick out the things through the side zipper of the basket.

1. 將盛物籃前端的2條固定帶 ① ② 先繞過車座架再連接U型鉤固定。  
Pass the front fixing belts ① ② thru the seat frame and fasten to the U-shaped hook.

2. 將盛物籃後端的2條固定帶 ③ ④ 繞過鋁車架再連接U型鉤固定。  
Pass the rear fixing belts ③ ④ thru the aluminum frame and fasten to the U-shaped hook.

3. 將盛物籃底部固定帶 ⑤ 繞過後支架再連接U型鉤穿反固定。  
The bottom fixing belt ⑤ pass thru the rear stay and loop fasten to the U-shaped hook.

4. 最後將固定帶穿反U型扣後，拉扯儲物籃作確認。  
To ensure by pulling the basket after the rear fixing belt loop fasten to the U-shaped buckle.

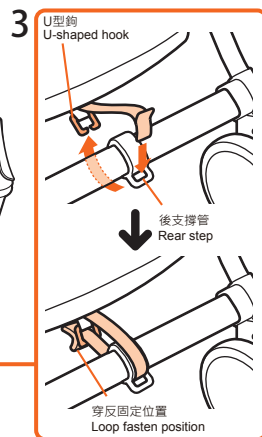
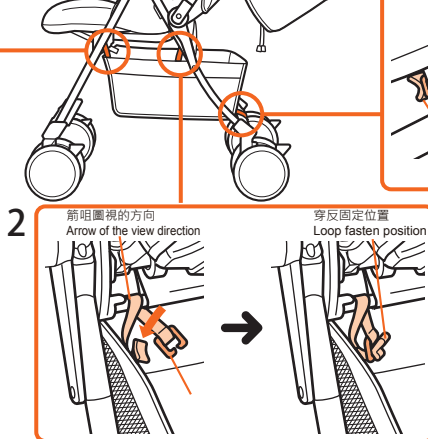
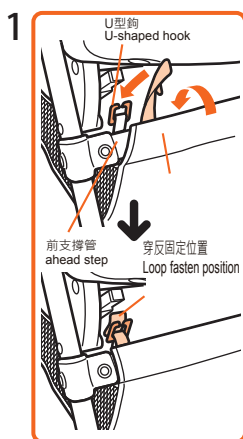
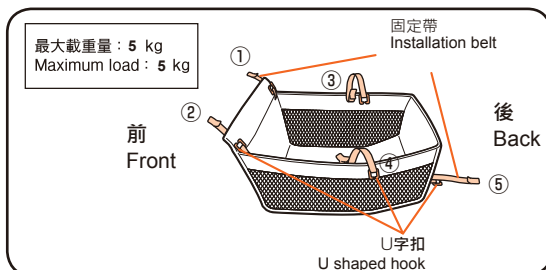

## 安全帶安裝方法 Attaching the seat belt

### 安全插扣的安裝方法 Attaching the insert plastics

※ 在座墊上安裝腰帶方法請參閱本頁下半部份的1,2點。

Refer to Pt.1 and Pt.2 on the 2nd half of this page for [Attaching waist belt to the seat cushion].

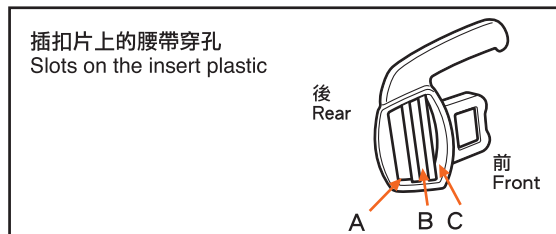

**警告 WARNING**

- 如插扣片未完全安裝好，安全帶有可能在使用時意外鬆脫。請於使用前確認插扣片和安全帶已經牢固裝好。  
Insecured insert plastics may get detached accidentally when in use. Make sure the insert plastics are secured before use.

1. 把腰帶穿過(A)孔，這時腰帶是從插扣的背面穿向正面的。  
Pull the waist belt from rear side of insert plastic to the front through slot (A).
2. 將在外側的腰帶從(B)孔穿回內側。  
Put the waist belt from the front side of the insert plastic to the rear through slot (B).
3. 將在內側的腰帶從(C)孔穿往外側。  
Put the waist belt from the rear side of the insert plastic to the front through slot (C).
4. 再將腰帶由插扣外側，從(A)孔穿回內側。(腰帶將穿過(A)孔兩次，疊在一起。)  
Put the waist belt from the front side of the insert plastic to the rear through slot (A). (Waist belt should pass through slot (A) 2 times.)

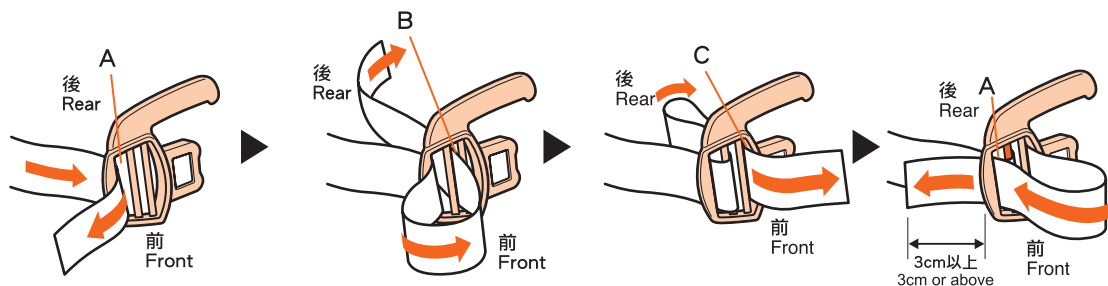

※ 注意腰帶末端應留下3cm以上之長度。  
Make sure to leave at least 3cm at the belt end.

### 安裝肩帶 Attaching the shoulder belt 어깨벨트 장착방법

請將肩帶穿過座席上的穿孔，然後裝到座墊上。  
Pull the shoulder belts through insert outlets ① on the seat and put through the seat belt insert ② of cushion.

- 請使用相同高度的椅墊肩帶穿孔和座席帶穿孔。  
Use the same level of shoulder belt insert outlets on the seat cushion as well as on the base seat.
- 於經常需要調節靠背角度時，請使用下方的肩帶穿孔。  
Use the lower shoulder belt insert outlets for child who may need frequent use of reclined seat.

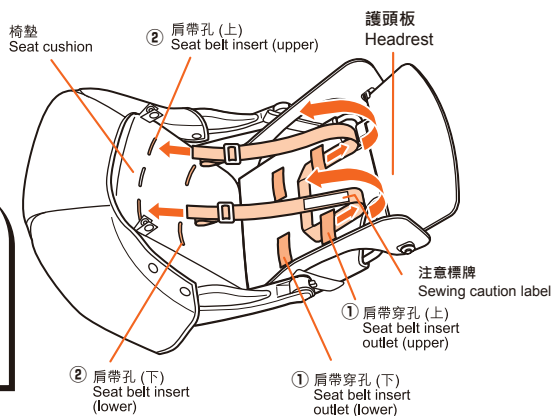

座墊拆除，安裝方法  
Installing and detaching the seat cushion

**警告 WARNING**

- 不要在未裝有座墊的推車上乘坐孩子。可能有夾傷孩子手和腳的危險間隙。  
Do not use a stroller without a seat cushion properly attached. Otherwise the child's hands or feet may be pinched in the gaps on stroller.
- 請不要使用破損或脫線的座墊，座墊不能發揮原有的保護作用或孩子可能吞食其中的填充棉。  
Do not use seat cushion on which rift is found. Otherwise the seat cushion may not function as designed or the child may have chance to swallow the material inside of the cushion.
- 安裝座墊時，請確實連接好固定扣。不完全的安裝可能導致孩子受傷或物品損壞。  
Make sure all zippers or snaps are secured before use. Otherwise accident or damage to stroller may be caused.

※ 關於座墊 About the seat cushion

孩子的服裝或鞋子上有魔术貼時，請注意不要與座墊上的魔术貼相粘結。粘結網孔織物有可能拉傷表面。  
Beware of the child's clothes or shoes if equipped with Velcro tape. Velcro tape may scratch the seat surface.

安裝方法 Installing the seat cushion

1. 將腰帶穿過手推車背面底座上的腰帶穿孔，同時亦將肩帶穿過底座和椅墊上的肩帶穿孔。  
Pull the waist belt through the waist belt insert outlets on the base seat and also pull the shoulder belt through the shoulder belt insert outlet on the base seat.

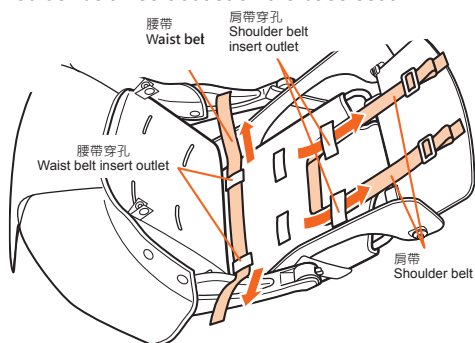

3. 將2個短帶鈕釦扣在背管的底座上。  
Secure the 2 short belt snaps to the back pipe of the base seat.  
將2個長帶鈕釦扣在背管的底座上。  
Secure the 2 long belt snaps to the back pipe of the base seat.

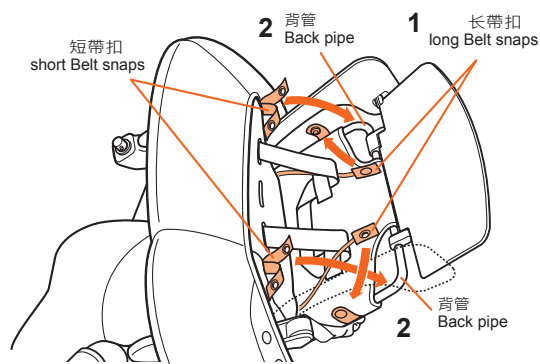

2. 將肩帶、腰帶透過穿孔抽出椅墊座面。  
Pull out the shoulder belts and the waist belt through the shoulder belt and waist belt insert outlets of seat cushion.

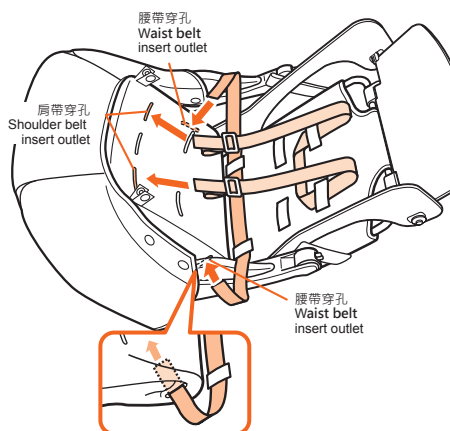

4. 將椅套上的2個鈕釦扣在底座背面。  
Fasten the 2 snaps on the upper seat cover to the back of seat base.

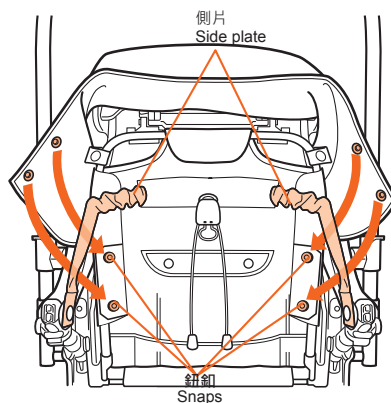

## 座墊拆除，安裝方法 Installing and detaching the seat cushion

5. 把股帶從座墊上穿出。  
Pull the crotch belt out of the seat surface.

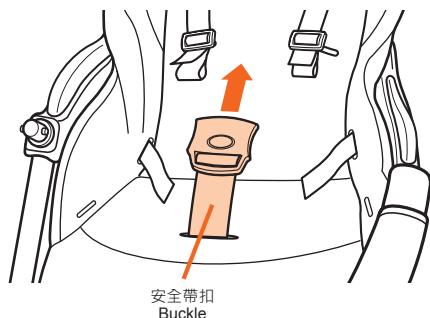

6. 先辨認出左右插扣片，再將左右插扣片分別安裝上左右腰帶上。  
Attach the insert plastics to the waist belts after confirming the left and right buckles.

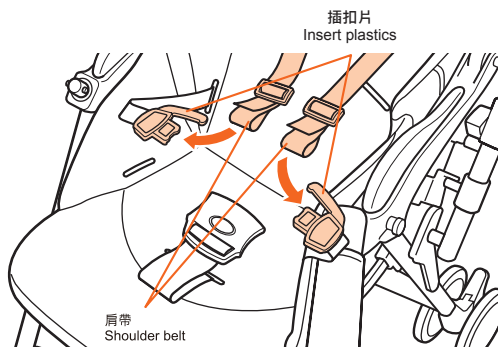

7. 將插扣片插進中央的安全帶扣內。  
Fasten the insert plastics into the centre buckle.

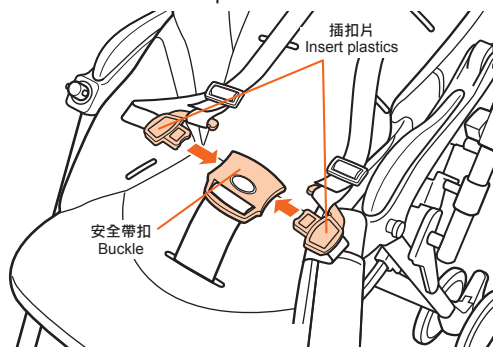

8. ① 連接座架和坐墊底部兩旁的兩處固定帶扣  
Secure the belt hooks at the sides in between the base seat and the seat frame.

- ② 使用腿部支撐杆，連接座架和坐墊底部前端的兩顆鈕扣。  
Using the Leg support bar, Secure the snaps of the seat tip in between the base seat and the seat frame.

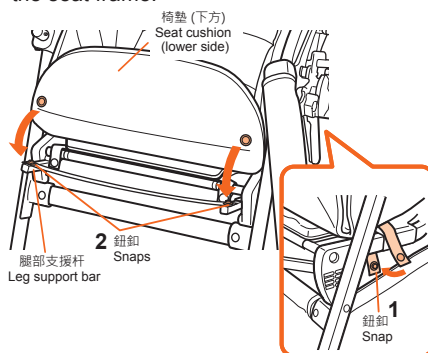

## 座墊的拆除方法 Detaching the seat cushion

請按安裝座墊的相反順序拆除座墊。

- 解除固定帶，然後從底座解除上下的安裝袋子。
- 將肩帶、腰帶、中央帶從座墊上抽出。

Please detach the seat cushion according to the reverse steps of attaching the seat cushion.

- Release the installation belt, remove the installation pocket (upper) and (lower) from the base seat.
- Remove the shoulder belt, waist belt and crotch belt from the seat cushion.

有關座墊

當幼兒的衣服或鞋上附有魔術貼時，請注意勿讓魔術貼接觸到座墊表面，以免魔術貼刮損座墊表面。

About the seat cushion

Beware of the child's clothes or shoes if equipped with velcro tape. Velcro tape may scratch the seat surface.

懷抱型座墊的安裝方法  
Installing the dacco cushion

**注意 CAUTION**

- 使用護頭墊時，必須將衝擊吸收素材墊安裝到護頭墊內使用。  
Make sure to apply the Egg Shock α pad when using the head support.
- 當手推車椅背為直立位置時，護頭墊可能會抵住幼兒頭部。此時應將護頭墊拆除。  
Remove the head support to use when the child's head is too tight against it at an upright backrest.
- 請勿使用有破損的保護墊，以免幼兒誤吞墊內的物料，而保護墊也可能失去原有保護功能。  
Do not use support cushion on which any rift is found. Child may swallow the material inside and the cushion may have lost its protective functions.

- 請根據幼兒體形安裝懷抱型座墊。  
Set the support cushion according to the child's body size.

護頭墊的安裝位置  
Correct position of head support

護頭墊的護墊部份，應該剛剛抵幼兒頸項。  
The cushion pad of the head support should just touch at the child's neck



懷抱型座墊的參考安裝時期  
Support cushion installation reference

	1個月 1 month	獨自乘坐前期(7個月) Starting to sit without aid	36個月 36 months
護頭墊 Head pad	←→		
Egg shock 墊 Egg shock pad	←→		←→
護背連臀墊 Body and hip support	←→		

※1 將Egg shock 墊放入椅墊上的口袋使用。  
Put Egg shock into pocket on seat cushion to use.

※2 月齡只作參考，請依照幼兒體格判斷後使用。  
Indicated age for reference only. Please apply according to child's body size.

護頭墊的安裝方法  
Installing the head support

將護頭墊安裝活動椅墊上。  
Attach head support to seat cushion.

將護頭墊上的魔術貼 **a**，穿過護頭墊穿孔（上下共兩處），然後貼在活動椅墊內側的魔術貼 **b**（上下共兩處）上。  
Pull Velcro tape **a** on head support through head support insertion outlets (upper or lower) and secure it onto Velcro **b** (upper and lower) on inner side of seat cushion.

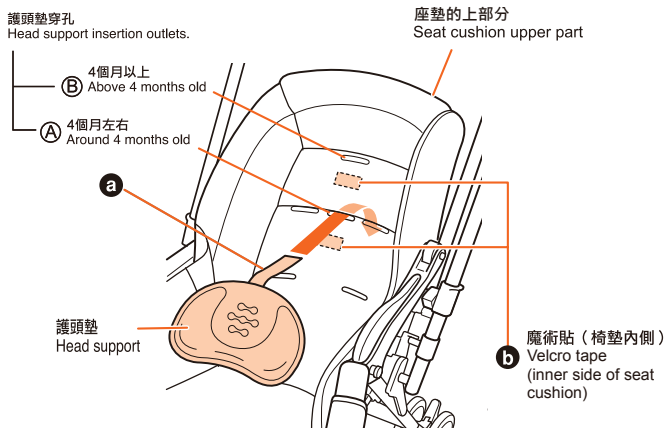

安裝護頭墊有困難時，可將活動椅墊上部的椅套翻開，然後看著椅墊內側安裝。  
Open upper part of seat exposed for easier installation of head support.

有關護頭墊穿孔(a)(b)的參考  
Reference for head support insertion outlets **A****B**

- A** 大約供1個月至4個月的幼兒使用。  
**A** for child from around 1 month to 4 months
- B** 大約供4個月至7個月的幼兒使用。  
**B** for child from around 4 months to 7 months

## 護背連臀墊的安裝方法 Installing body and hip support

1. 將背部和臀部支援座面一方的固定帶，穿過椅墊側的帶穿孔，再將背面一方的固定帶，穿過椅墊側的帶穿孔。

Pull the seat front belts on the body & hip support through the insert outlets on the inner side of the detachable seat pad, and then the backrest belts on the body & hip support through the belt insert outlet on the seat cushion.

腰帶必須穿過護背墊連臀墊上的腰帶穿孔。  
The waist belt should be pulled through the waist belt insert outlet on the body and hip support.

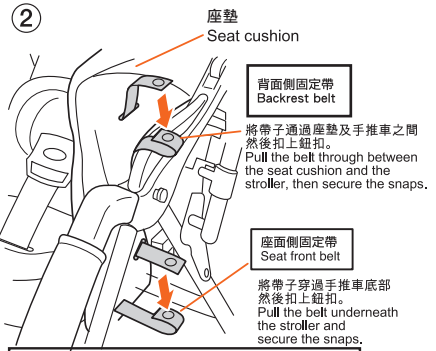
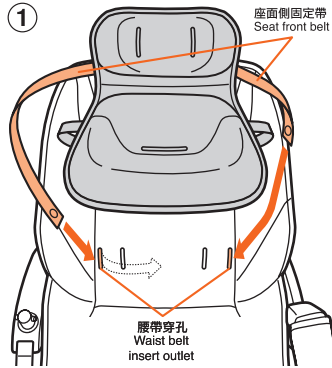
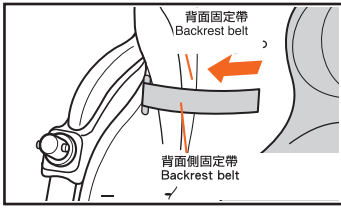

中央帶必須穿過腰背墊的中央帶穿孔。  
The crotch belt must be pulled through the crotch belt insert outlet on the body and hip support.

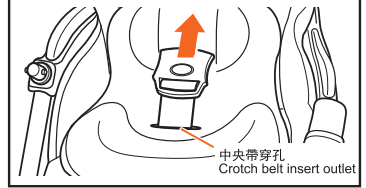

2. 在椅墊下方，將背部和臀部支援的固定帶兩端鈕扣扣上。(必須將椅墊上的中央帶從背部和臀部支援上的中央帶穿孔抽出座面)

Snap the 2 seat front belts together under the seat. (The crotch pad on the seat pad must be pulled through the crotch pad insert outlet on the hip support out to the seat surface.)

不足三歲幼兒的體格有可能已不適合使用腰背墊，此時，請停止使用。  
Please stop using the body and hip support if it does not fit your child's body size even if it is under 3 years old.

使用Egg shock α 墊  
To use with egg shock α pad

放進護頭墊內使用時 Putting into the head support to use

### 注意 CAUTION

請注意假如將EggShock Super 墊放到紙張等上面時，有可能會滲透痕跡。

Stain may be left if placing the EggShock Super onto paper surface.

### 警告 WARNING

請注意勿讓幼兒將EggShock Super 墊放進口中或拉扯玩要，以免造成意外。

Do not let the child to place the EggShock Super into its mouth or play around with it in case of accidents.

Eggshock墊可以安裝到Dacco墊的頭墊部份之內，保護幼兒頭部免受推行時的震動影響。

The Eggshock pad can be inserted into the head support of Dacco Seat to protect child from the vibrations from the ground when strolling.

請在頭墊背部的口袋進行安裝

\*請注意Eggshock Super墊的頭墊(700系列)部份上下前後方向，然後安裝到頭墊內側的靠近己方的口袋之內。

Insert the Eggshock pad from the rear pocket of the head support.

\*Make sure the head support of Eggshock Super (700 series) is the correct direction before installing it into the pocket of the head support.

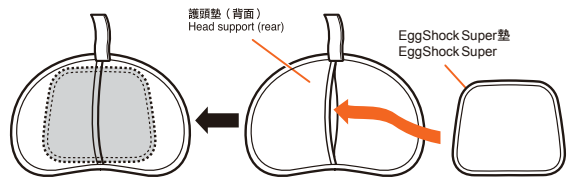

放進椅墊內使用時 Putting into the seat cushion to use

當幼兒的頭部抵住頭板時，將頭墊拆除，並將頭墊內的Eggshock Super 墊放進椅墊內使用。將椅墊頭靠背面的專用口袋打開於Eggshock Super 墊。

When the child's head reaches the headrest, please remove the head support. Remove the Eggshock super pad from the head support. Open the pocket at the back of seat cushion (upper part) and put the Eggshock Super into it.

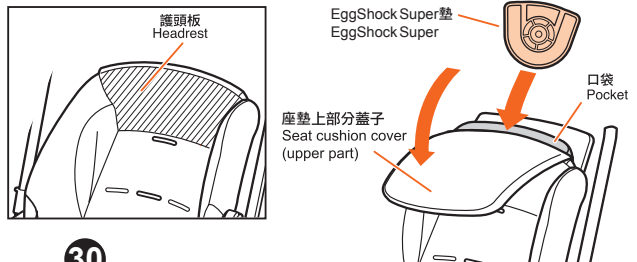

縫制品的洗滌方法  
Washing the seat cushion

- 肩帶、腰帶、護欄套、中央帶墊、肩帶套、腳套的洗滌  
Washing of the shoulder belt, the shoulder belt cover, front guard cover, waist belt, crotch belt cover and foot-cover.
- 水溫30度以下手洗。  
Hand wash in water below 30°C.
- 不要使用洗衣機。  
Do not use washing machine.
- 可以使用普通洗滌劑，但不要使用漂白劑或添加漂白劑的洗滌劑。使用請仔細閱讀洗滌劑的使用說明。  
Do not use bleach or detergent containing bleaching agent. Refer to the user guide of the detergent before washing.
- 不要長時間浸泡，短時間洗滌即可。否則可能有褪色現象。  
Keep washing time short to avoid possible decolorization.
- 充分漂洗，輕柔脫水，整形後攤平晾乾。  
Flat dry in shade area after washing.
- 不要使用乾燥機和乾洗機。  
Do not use drying machine or dry cleaning.
- 洗滌前扶手護套時，不要用力搓洗。  
Do not forcefully rub when washing the front guard cover.
- 充分漂洗，輕柔脫水，整形後攤平在陰涼處晾乾。  
Gentle spinning after rinsing thoroughly. Straighten shape and lay on flat area for cool dry.
- 車篷、盛物籃的洗滌  
Washing the canopy and basket
- 不要把車篷、儲物籃落水洗滌，用刷子或海綿沾取30度水溫的洗滌劑擦洗污垢。  
Do not soak into the water. Use water below 30°C and use sponge or brush wipe off the dirt.
- 請小心不要被車篷上的膠件或盛物籃上鈕釦弄傷。  
Be careful not to be hurt by the plastic parts on canopy and the snaps from basket.
- 用洗滌劑去除污垢後，用沾水的布或海綿擦去多餘的殘留洗滌劑。  
After wipe off the dirt by detergent, use a cloth or sponge to wipe off the excess water and detergent.
- 乾燥過程中，用乾布擦去多餘水分，然後放於陰涼處晾乾。  
Dry in shade area after wipe off water by dry cloth during the drying process.
- ※ 產品特性所致，有些顏色可能褪色。  
Due to the characteristic of the product, the color may fade after numbers of washing.
- ※ 洗滌時，推薦使用以天然脂肪酸為基料不含螢光劑、漂白劑和氧化物的康貝內衣洗滌劑。另外，為更舒適使用，建議仔細地清洗。  
It is recommended to use Combi detergent for underwear which is made of natural fatty acid as the ingredient and does not contain bleach and oxide. Furthermore, it is strongly recommended to wash thoroughly for better comfort.
- ※ 由於保管方式不同，有生霉的情況發生。仔細洗滌，後注意要保持清潔。  
Always keep clean due to the condition of storage, the mildew may be generated.
- ※ 清洗座墊及護頭墊時，請先將Egg Shock墊取出。  
Please remove the Egg Shock a pad before cleaning the seat cushion and head support.

有關車體的清潔  
Cleaning the stroller body

注意 CAUTION

- 只可使用中性的洗滌劑清潔車體否則可能使部件變質，老化和損壞。  
Only use neutral detergent to clean the stroller body in order to avoid damage or ageing to the parts.

- 車輪、塑料部件以及金屬部件髒污時，用布沾取清水擦洗。髒污嚴重時，可用布沾取稀釋過的中性洗滌劑擦洗，然後用布沾取清水擦去殘留的洗滌劑。Use a piece of damp cloth to clean wheels, plastic or metallic parts. For serious dirt, use diluted neutral detergent for cleaning.

加潤滑油  
Adding lubricant

注意 CAUTION

- 孩子接觸可能性比較大的前扶手，側扶手等處不要加潤滑油。  
Make sure no oil or lubricant is left on parts such as front guard or armrest where baby may have chance to lick.

- 有雜音發出或有動作不靈活時，有必要加潤滑油時，必須只能加注少量的潤滑油加潤滑油前，加油點首先必須要清除泥土和污垢。如果加潤滑油多，可能容易吸附灰塵，反而降低功能。  
It is possible to add lubricant when the operation or movement of the baby stroller is found not smooth. Before adding the lubricant, please clear the mud and dirt. Do not, however, add too much lubricant as it may get dirt easily and cause malfunction.
- 以下地方請不要加注潤滑油。  
Do not add lubricant on the following parts.

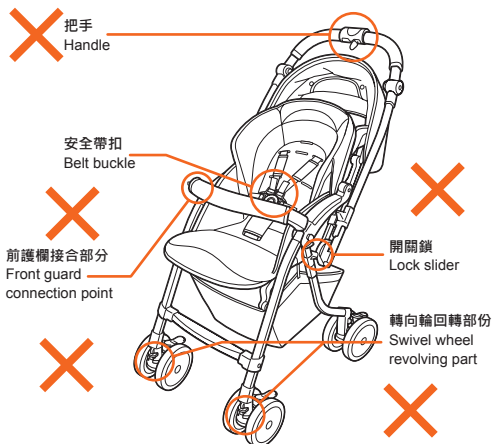



**⚠ 注意 CAUTION**

- 請不要在近火處，夏季的車等高溫場所保管推車。此外上面壓放重物或在受力狀態下保管等都有可能造成故障和產品變形。

**Avoid storing the stroller in places that under high temperature, near heat source or inside a car (especially the car in summer). Exposure to high temperature may damage or deform the stroller.**

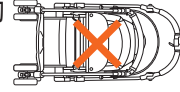

- 在保存手推車時，請勿在手推車上放置重物，以免其損壞或變形。

**Please do not place loads on the stroller during storage to avoid deformation.**

- 如直立存放手推車時，請先鎖上轉向輪鎖及停車鎖以免手推車易於翻倒。

**If the baby stroller is stored in vertical position, please make sure the swivel is locked and please lock the stopper as well to avoid the baby stroller falling down easily.**

- 請不要如右圖般存放手推車以免變形或損壞。

**Please do not store the baby stroller as illustration on the right side.**

- 請在避開陽光直射，乾燥的遠離雨水和灰塵侵襲的場所保管在室外保管時，建議用防護套覆蓋。

**Do not place the stroller near fire or hot area. Do not place load onto the stroller, otherwise the stroller frame may be deformed.**

# MEMO

-----

-----

-----

-----

-----

-----

-----

-----

-----

-----

-----

-----

-----

-----

-----

-----

-----

-----

-----

-----

-----

-----

-----

MEMO

Dotted lines for writing a memo.

產品名稱及型號：幼嬰兒手推車 Caldia  
製造年份：請參考車體把手貼紙  
進口商：台灣康貝股份有限公司  
地址：台北市11493內湖路一段360巷6號6樓  
電話：(02)7720-8585  
統一編號：12946262  
製造廠商：Combi Corporation  
地址：2-6-7, Motoasakusa, Taito-ku,  
Tokyo 111-0041 Japan  
原始製造國：中國  
適用年齡：一至三十六個月 最大承載重量：15kg以下  
置物籃最大承載重量：5 kg 以下  
主要成份或材質：合金、布、塑膠  
使用方法：請依說明書組合使用  
注意事項：乘坐時務必繫好安全帶  
緊急處理方法：盡速送醫急救

## **警告！**

禁止於樓梯間使用手推嬰幼兒車

# Combi Corporation